



+24V

0V



Address

High



Low

Fieldbus Components

ricos *ricos* TP

Address



Fieldbus components
Contents

ricos

Fieldbus components

Contents

ricos

Contents – Fieldbus components

		Page
ricos	Remote I/O (IP 20)	487
ricos ^{TP}	Remote I/O for extended requirements (IP 20)	529



+24V

0V

Address

High



Low

Fieldbus Components

ricos

Address



Contents – Bus systems

				Page
Selection by function				490
General information				492
Technical information on bus systems				493
Operating and display functions				496
Modular system Bus coupler	Profibus DP		ricos BC-DP	499
			ricos EC-DP	504
	CANopen		ricos BC-CANopen	500
			ricos EC-CANopen	505
	DeviceNet		ricos BC-CAN-DN	500
		ricos EC-CAN-DN	505	
Interbus		ricos BC-S	499	
		ricos EC-S	504	
Ethernet		ricos BC-Ethernet	501	
PLC	Ethernet		ricos BC-Ethernet PLC	502
I/O modules	binary I/O	8 I/O for 24 V DC	ricos 8 I/O	507
		8 I and 8 I/O for 24 V DC	ricos 8I 8I/O	510
		16 I for 24 V DC	ricos 16 I	507
		16 O for 24 V DC	ricos 16 O	510
		8 O for 24 V / 2A DC	ricos 8O 2A	511
		8 O for 24 V DC negative	ricos 8O NEG	511
		4 O, relay outputs	ricos 4O RELAY	512
		4 I for 115 V AC	ricos 4I AC 115V	508
		4 I for 230 V AC	ricos 4I AC 230V	508
	Interface	RS 232 / RS 485	ricos RS 232/485	513
Counter module	2 x 32 bit / 4 x 16 bit	ricos COUNTER	515	
Positioning module	2 x incremental encoder	ricos POSITION	515	
Analog I/O	4 I for Pt 100/1000	ricos 4AI/PT100	517	
	4 I for thermocouples type J/K/T	ricos 4AI/TC	517	
	4 I for 0 through 10 V	ricos 4AI/10V	519	
	4 I for ±10 V	ricos 4AI/±10V	519	
	4 I/O for 0 through 10 V	ricos 4AI4AO/10V	520	
	4 I/O for ±10 V	ricos 4AI4AO/±10V	520	
	4 I for 0 through 20 mA	ricos 4AI/20MA	521	
	4 I for 4 through 20 mA	ricos 4AI/4-20MA	521	
	4 I/O for 0 through 20 mA	ricos 4AI4AO/20MA	522	
4 I/O for 4 through 20 mA	ricos 4AI4AO/4-20MA	522		

Contents – Bus systems

				Page
Compact modules	Profibus DP	8 I/O for 24 V DC	ricos COM-DP 8I/O	524
		8 I and 8 I/O for 24 V DC	ricos COM-DP 8I 8I/O	524
		16 I for 24 V DC	ricos COM-DP 16 I	524
		16 O for 24 V DC	ricos COM-DP 16	524
	CANopen	8 I/O for 24 V DC	ricos COM-CO 8I/O	525
		8 I and 8 I/O for 24 V DC	ricos COM-CO 8I 8I/O	525
		16 I for 24 V DC	ricos COM-CO 16 I	525
		16 O for 24 V DC	ricos COM-CO 16 O	525
	DeviceNet	8 I/O for 24 V DC	ricos COM-DN 8I/O	525
		8 I and 8 I/O for 24 V DC	ricos COM-DN 8I 8I/O	525
		16 I for 24 V DC	ricos COM-DN 16 I	525
		16 O for 24 V DC	ricos COM-DN 16 O	525
	Interbus	8 I/O for 24 V DC	ricos COM-S 8I/O	524
		8 I and 8 I/O for 24 V DC	ricos COM-S 8I 8I/O	524
		16 I for 24 V DC	ricos COM-S 16 I	524
		16 O for 24 V DC	ricos COM-S 16 O	524

Remote I/O Selection per function

ricos

CATALOG PAGE

FUNCTION	
FIELDBUS	Profibus DP
	CANopen
	Interbus
	DeviceNet
	Ethernet Modbus TCP/IP
PLC (openly programmable)	Ethernet TCP/IP
DIGITAL INPUTS AND OUTPUTS	24 V DC input
	115 V AC input
	230 V AC input
	24 V DC 1 A output
	24 V DC 2 A output
	24 V DC 1 A neg. output
	Relay output
ANALOG INPUTS AND OUTPUTS	Pt 100/1000
	Thermocouple J/K/T
	Voltage input 0...10 V
	Voltage input +/- 10 V
	Voltage output 0...10 V
	Voltage output +/- 10 V
	Current input 0...20 mA
	Current input 4...20 mA
	Current output 0...20 mA
	Current output 4...20 mA
FUNCTION INPUTS AND OUTPUTS	Counter input + 24 V
	Incremental input + 24 V
	Interface RS 232/422

Remote I/O General information

ricos

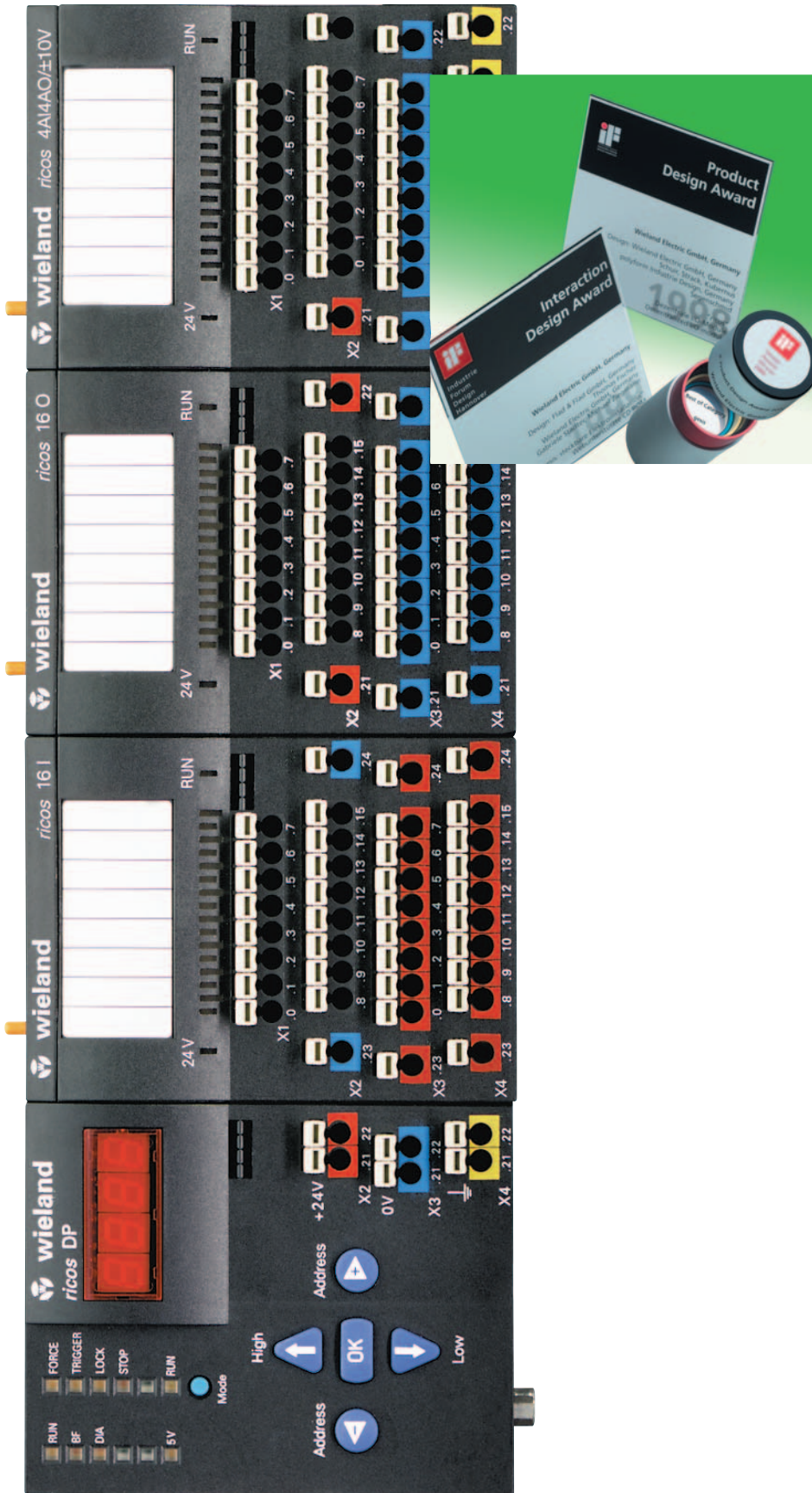

A field bus system introduces a high level of performance when compared to conventional wiring technology. The possibility for intelligent and convenient distribution of signals is a significant benefit of digital fieldbus technology.

Nowadays, there are a variety of functional and topological variants available on the market. This broad spectrum is due to the various requirements of the individual branches of industry as well as the interests of the manufacturer's company or international standards.

As a global company, Wieland fulfills these requirements and offers the user a universal fieldbus system with a winning design in **ricos**:

- Fieldbus couplers for all major fieldbus systems
- Openly configurable modules for digital and analog signals
- Modular assembly of fieldbus nodes
- Integrated diagnostic tools in the bus coupler enables commissioning functions such as Force, Trigger and Lock without the need for additional software
- Full range of functionality
- Spring clamp terminations for secure and rapid connection
- Economy bus coupler
- Function modules can be replaced without disconnecting the wiring
- High degree of EMC resistance due to integrated ground connection to the mounting rail
- Compact housing dimensions
- Universal marking

Remote I/O

Technical information on bus systems

PROFIBUS



PROFIBUS (process fieldbus) has a number of variations including PROFIBUS-DP which is established in DIN 19245, section 3 and integrated in the European fieldbus standard EN 50170. PROFIBUS has an optimum transmission rate for opening up the object-related system area as well as the sophisticated sensor/actuator area.

It is tailor-made to the requirements for fast, efficient data exchange between the programmable controllers and the distributed devices such as digital or analog input/output modules and drives



for time-critical applications, where the service development of Layer 7 is omitted. This shift of PROFIBUS-DP to the field level makes it possible to save cable. PROFIBUS-DP uses proven characteristics of the PROFIBUS transmission technology and the bus access protocol (DIN 19245, section 1 and 2) reduced to specific functions so that the high demands for system reaction time in the distributed interface systems can be met.

It is also possible to operate PROFIBUS-FMS and PROFIBUS-DP on a single cable. Particularly interesting possibilities are produced by so-called combination devices which unite the characteristics of both variations.

PROFIBUS-DP stands out due to:

- Short reaction times
- High level of interference immunity
- Replacement of the cost-effective transfer of measured values in 0(4) to 20 mA technology.

The data transmission with the distributed devices (slaves) is primarily selected at cyclic intervals as in a normal master/slave process. The central controller (master) reads the input data from the slaves and writes the output data to the slaves. PROFIBUS-DP-V1 also supports the acyclic exchange of data. PROFIBUS-DP operates with a maximum transmission rate of 12 Mbit/s and enables the transfer of 1024 bits of input/output data, distributed to 32 devices in less than 2 ms.

Properties:

- Line structure (with passive bus interface)
- Maximum length for electrical structure is 9.6 km and 90 km for optical structure
- Networking covers entire area due to division of the system into a maximum of 5 bus segments (via repeaters) up to 1.5 Mbit/s
- Number of repeaters that can be used and thus the transmission range is dependent on the baud rate
- Max. 124 devices (over all bus segments), max. 32 devices per segment
- Bus access according to token passing procedure; normal operation only with a master and polling
- High transmission rate (real-time capability for PLCs is the main reason behind DP)
- Data transmission via twin-core cable or optical fibre (active bus interface)
- Electrical structure with shielded, twisted, twin-core cable and RS 485 interface
- Bit coding in NRU code (Non Return to Zero)
- Distributed devices and field devices can be connected and disconnected during operation
- Comprehensive diagnostics options
- Open system (DIN 19245, section 3; European standard EN 50170)

CAN

In 1983, the auto industry formulated its requirement for a bus system for use in motor vehicles. An electrical two-wire bus should replace the extensive cable harnesses for the connection of electrical systems. This was also urgently needed as the traditional cable harnesses in vehicles already exceeded 2 km in length and a mass of over 100 kg. However, requirements arose which could not be met by the bus systems that were available at that time.

In 1985, the Controller Area Network (CAN) was presented as a solution. The CAN-Bus was developed in a collaboration between Robert Bosch and INTEL Semiconductor. Meanwhile, CAN created a broad area of applications for itself in automation engineering in addition to the motor vehicle sector. Nowadays, CAN can be found in mobile systems as an internal communication system for machines or plants, in production automation, in the lower field area of process automation, in building management systems as well as many other applications.

The user organisation CiA (CAN in Automation) has been in existence since 1992 and incorporates over 200 manufacturers and users of programmable controllers, sensors, actuators, software and services [Trum95]. The CAN-Bus was standardised in the international norm ISO 11898 and thus became an open system.

The reason for the broad appeal of CAN, apart from the performance characteristics, is the availability of extremely cost-effective switching circuits, limited by the high number of items guaranteed in the auto industry.

Properties:

- Line structure (with passive bus interface)
- Number of devices only limited by capacity of driver modules
- Expansion dependent on the transmission rate: 40 m at 1 Mbit/s; 1000 m at 50 kbit/s
- Twisted pair cable with terminating resistor, optical fibre
- Object-oriented messages, broadcast and multicast with acceptance test
- Multimaster network
- Bus access via arbitration in bits according to the CSMA/CA procedure; real-time capability for messages with higher priority
- Max. transmission rate of 1 Mbit/s
- Very high level of data security (HD = 6); error detection and signalling, automatic disconnection of faulty stations (Node Guarding)
- Various chips and microcontrollers support the protocol
- Open system (ISO 11898 and CiA DS 301)

These were in particular:

- High level of safety against electromagnetic interference
- Real-time capability for fast processes such as ignition and ABS
- High degree of reliability
- Economic price for applications involving mass production



Remote I/O Technical information on bus systems

PROS



The INTERBUS was specially developed by Phoenix Contact for use in machine systems and rapid processes. This fieldbus system is therefore primarily used in production automation at system level and as an object-related fieldbus for the connection of sophisticated sensors and actuators. It can be used in standard PLC applications and industrial PCs with relatively little cost and effort.



The INTERBUS has been structured using point-to-point connection as an active, coupled ring. Each bus device uses a separate outgoing and incoming cable. The return circuit required in ring systems from the last device to the first device is thereby avoided. The outgoing and return lines are fed into one cable. INTERBUS is thus similar to a line bus as regards the installation as only one cable is drawn from one device to another. A complete bus system is implemented with various bus devices. These are designated as interface modules, bus couplers, remote bus devices and local bus devices.

An interface module (master) operates as a central unit for data communication in the remote bus. The interface module also links the INTERBUS system with the

higher-level controller. The remote bus can be implemented with a maximum number of 512 stations and a maximum distance of 400 m between 2 devices. The data transmission rate is 500 kbit/s. The RS 485 standard is used for data transmission on a twisted pair cable. Each remote bus device is provided with a separate auxiliary power supply and acts simultaneously as a repeater due to its active interface. Greater distances can thereby be achieved. There is also an electrical isolation of the routing INTERBUS segment. Remote bus devices are both input/output devices and interfaces to subordinate rings. There are also compound devices, so-called I/O bus couplers.

Since the addressing of the devices is not specified in the protocol for INTERBUS, the maximum number of bus devices is determined by the master firmware. Implemented firmware permits up to 512 remote bus devices. This produces the theoretically possible distance of 102 km for an INTERBUS system if copper cables are used. A maximum system expansion of 13 km is however currently guaranteed. Greater distances can be achieved when using other transmission media. Total expansions of 100 km are currently possible when glass fibre cable is used.

Properties:

- Ring structure with active coupling of the devices
- Remote bus with max. 512 devices, max. distance of 400 m, max. total expansion of 13 km with copper cable and 100 km with glass fibre
- Local bus with max. 8 devices, max. distance of 1.5 m, max. total expansion of 10 m
- Addressing of the devices according to their sequence in the ring
- Transmission rate: remote bus with 500 kbit/s, local bus with 300 kbit/s
- Remote bus uses interface based on RS 485 two-wire connection system
- Local bus uses CMOS level and has 4 core pairs for transmission
- Protection level up to IP 65 is possible
- High level of data security, several protection mechanisms (CRC etc.)
- Open system (DIN EN 19258; European standard 50254)

Remote I/O Operating and display functions

ricos

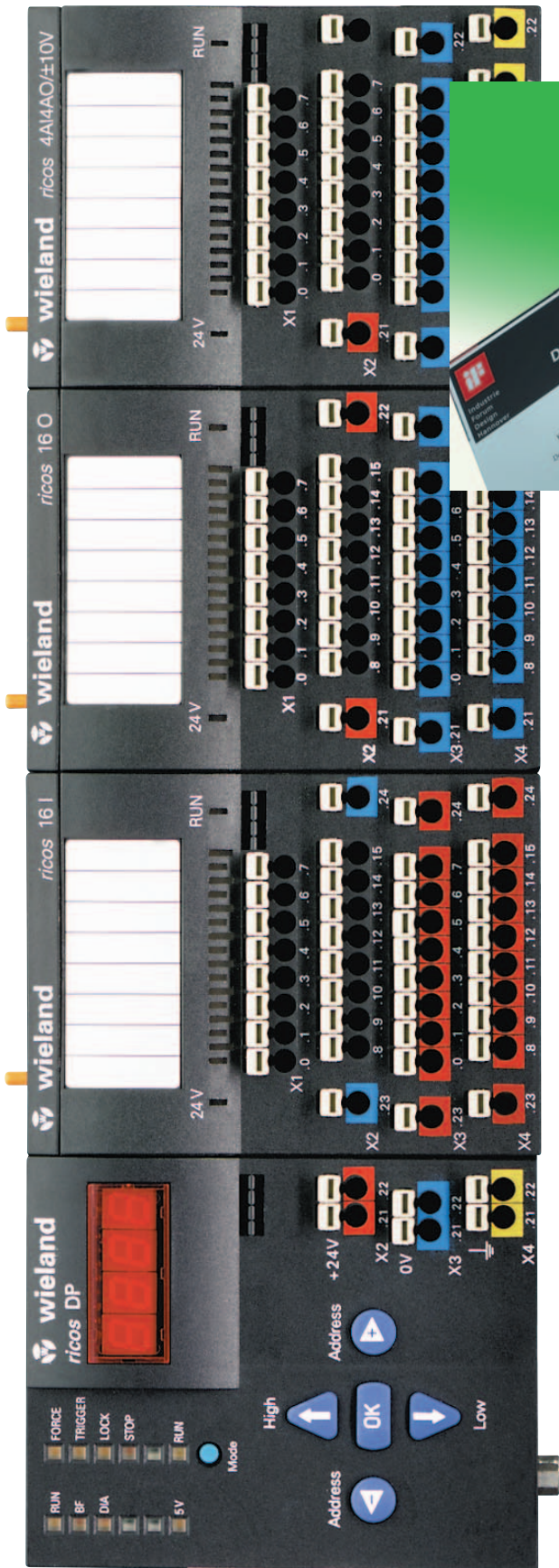

Digital and analog I/O channels can be operated manually without the fieldbus (offline) → in FORCE mode

The last 20 process images of the nodes can be recorded and displayed. → in TRIGGER mode

Analog and digital I/O channels can be 'frozen' at a fixed switching state to simulate parts of the system. → in LOCK mode

The outputs are switched off and the inputs are no longer available. → in STOP mode

ricos

Remote I/O

Bus couplers, economy bus couplers, compact modules

ricos

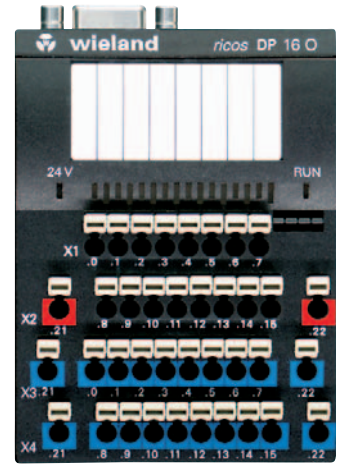

Would you like to ...

- use more than one fieldbus?
- shorten your commissioning process?
- simulate signals offline – locally and without a programming device?
- set I/Os without a PLC?
- read out analogue values locally?

... then you should use the **ricos** coupler with operating and display functionality!

- Commissioning without a fieldbus interface
- Fault location on site
- Display of the signalling states of all inputs and outputs for digital and analog values

ricos bus couplers offer:

- Connection to the latest fieldbus systems such as PROFIBUS DP, Interbus, CANopen and CAN DeviceNet
- Modules for rapid DIN rail installation
- Wiring via spring-clamp terminals
- Supplied with open clamping body
- Modules are wired from the front
- Plug-in distribution board on the module
- Compact dimensions of the modules
- Up to 8 modules can be connected in series on a bus coupler, up to 128 I/O signals are therefore possible per bus node
- Electronics can be replaced without disconnecting the wiring

If you do not require the operation and display functionality of the **ricos** bus coupler ...

... then we recommend our **ricos** economy bus coupler.

ricos bus couplers and economy bus couplers are fully compatible in their functionality.

If your control requirements are more complex ...

... we can offer you our **ricos** compact modules

ricos compact modules:

- Use of 4 compact module types for digital signal detection in fieldbus systems:
 - PROFIBUS DP
 - Interbus
 - CANopen
 - DeviceNet
- All modules are slaves with bus coupler functionality
- Efficient and space-saving addition for small numbers of I/Os

ricos housing data

Material	Makrolon 2805, Lexan 161R, Polyamide 6.0 GF20
Color	black
Flammability class	according to DIN VDE 0304 T3 (IEC 707) and UL 94-V-2
Creepage resistance	according to DIN VDE 0303 T1/06.84 CTI = 600
Permanent rigidity	according to DIN VDE 0304 20,000 h/5,000 h 100/115 °C
Dielectric strength	according to DIN VDE 0303 T2 (DIN 53481/>15 kV/mm)
Protection class	Class I according to IEC 536
Degree of protection	IP20 according to EN 60529
Free fall	falling height 1 m (DIN IEC 68-2-32), in packaging
Shock resistance	according to IEC 68 part 2, see "free fall" test
Relative humidity	10...95%, no condensation
Air pressure during operation	860...1060 hPa
Wire strip length	10 mm
Clamping body opening	2.4 x 1.5 mm according to IEC 999
Mounting rail	TS35
Weight	approx. 190 g

Remote I/O Bus couplers

ricos

Modular bus couplers with operating and display functionality for the following fieldbus systems:

- PROFIBUS DP
- Interbus



ricos BC-DP
PROFIBUS DP bus coupler
Approvals: ULus, Profibus certification

ricos BC-S
Interbus bus coupler
Approvals: ULus

Dimensions (mm): W x H x D
74 x 92 x 51

Description	Type	Part No.	Std. Pack	Type	Part No.	Std. Pack
Bus coupler with diagnostic functions	BC-DP	83.030.0000.1	1	BC-S	83.031.0000.1	1
Display of operating modes:						
FORCE mode: yellow LED						
TRIGGER mode: yellow LED						
LOCK mode: yellow LED						
STOP mode: yellow LED						
RUN mode: green LED						
System data						
Maximum number of nodes	126			256		
Transmission medium	Shielded copper cable 2 x 0.25 mm ² /AWG 23			Shielded copper cable 5 x 0.25 mm ² /AWG 23		
Maximum system expansion	100 m – 1200 m (dependent on baud rate/cable)			400 m (remote bus)		
Baud rate	9.6 kBaud...12 Mbaud			500 kBaud		
Internal bus refresh rate	2 ms			2 ms		
Bus connection	1 x D-SUB 9, female connector with shield			2 x D-SUB 9, female connector and plug with shield		
Technical data						
Maximum number of I/O bytes	64 E-Byte/64 A-Byte			20 E-Byte/20 A-Byte		
Number of I/O modules per node	8			8		
Number of digital I/O points per node	128			128		
Number of analog I/O points per node	32			32		
Address setting	3...126 (via keyboard)			automatic dependent on system		
Configuration	PC oder PLC			PC oder PLC		
Operating voltage	24 V DC, ±20 %, max. 5 % residual ripple			24 V DC, ±20 %, max. 5 % residual ripple		
Power consumption	< 125 mA (at 24 V without I/O modules)			< 125 mA (at 24 V without I/O modules)		
	< 500 mA (at 24 V with I/O modules)			< 500 mA (at 24 V with I/O modules)		
Insulation voltage	350 V AC, 50 Hz (system/supply)			350 V AC, 50 Hz (system/supply)		
Creepage distances and clearances	DIN EN 61131-2; DIN EN 50178			DIN EN 61131-2; DIN EN 50178		
Electrostatic discharge	EN 61000-4-2; 8 kV air; 4 kV contact			EN 61000-4-2; 8 kV air; 4 kV contact		
Electrostatic fields	ENV 50140; 10 V/m; 30...1000 MHz			ENV 50140; 10 V/m; 30...1000 MHz		
Interference immunity/emitted interference	EN 61000-6-2/EN 55011; limit value A; group 1			EN 61000-6-2/EN 55011; limit value A; group 1		
Burst	2 kV according to DIN EN 61000-4-4			2 kV according to DIN EN 61000-4-4		
Connection technology	Spring clamp terminal			Spring clamp terminal		
Wire range: fine-stranded/solid	0.14 mm ² – 1.5 mm ² /0.5 mm ² – 2.5 mm ²			0.14 mm ² – 1.5 mm ² /0.5 mm ² – 2.5 mm ²		
Ambient temperature	0 °C...+55 °C			0 °C...+55 °C		
Storage temperature	-25 °C...+75 °C			-25 °C...+75 °C		
Bus-specific status displays	RUN green LED RUN			RUN green LED RUN		
	Bus fault red LED BF			Remote bus disabled red LED RD		
	Diagnostics red LED DIA			Remote bus connected green LED RC		
	Operating voltage green LED 5 V			Bus access green LED BA		
				Operating voltage green LED 5 V		
Accessories						
Vertical bus connector		83.030.0010.0 (node)	1		83.031.0010.0 (incoming cable)	1
Vertical bus connector		83.030.0011.0 (terminator)	1		83.031.0011.0 (outgoing cable)	1
Horizontal bus connector		83.030.0012.0 (switch)	1			
Manual, German		05.591.3389.0	1		05.591.3389.0	1
Manual, English		05.562.1389.0	1		05.562.1389.0	1
GSD file and Word document for labels		05.591.3255.0	1		05.591.3255.0	1
8 digit marking tag, blank		04.242.1553.0	500		04.242.1553.0	500
8 digit marking tag, with inscription (on request)						
End clamp for DIN rail		Z5.522.8553.0	100		Z5.522.8553.0	100

Remote I/O Bus couplers **ricos** OS

Modular bus couplers with operating and display functionality for the following fieldbus systems:

- DeviceNet
- CANopen



ricos BC-DeviceNet
DeviceNet bus couplers

Approvals: cULus



ricos BC-CANopen
CANopen bus couplers

Approvals: cULus

Dimensions (mm): W x H x D
74 x 92 x 51

Description	Type	Part No.	Std. Pack	Type	Part No.	Std. Pack
Bus coupler with diagnostic functions	BC-DEVICENET	83.032.0000.1	1	BC-CANOPEN	83.033.0000.1	1
Display of operating modes:	incl.1 bus plug			incl.1 bus plug		
FORCE mode: yellow LED						
TRIGGER mode: yellow LED						
LOCK mode: yellow LED						
STOP mode: yellow LED						
RUN mode: green LED						
System data						
Maximum number of nodes	64 with Repeater			126		
Transmission medium	Shielded copper cable trunk line AWG 15, 18 Shielded copper cable drop line AWG 22, 24			Shielded copper cable 4 x 0.25 mm ² /AWG 23		
Maximum system expansion	100 m – 500 m (dependent on baud rate/cable)			100 m – 500 m (dependent on baud rate/cable)		
Baud rate	125/250/500 kBaud (setting via keyboard)			10 kBaud...1 MBaud (setting via keyboard)		
Internal bus refresh rate	2 ms			2 ms		
Bus connection	5 pole connector, screw			5 pole connector, screw		
Technical data						
Maximum number of I/O bytes	64 E-Byte/64 A-Byte			9 R-PDO's; 9 T-PDO's		
Number of I/O modules per node	8			8		
Number of digital I/O points per node	128			96		
Number of analog I/O points per node	32			24		
Address setting (MAC ID)	1...63 (via keyboard)			1...126 (via keyboard)		
Configuration	PC or PLC			PC or PLC		
Operating voltage	24 V DC, ±20%, max. 5% residual ripple			24 V DC, ±20%, max. 5% residual ripple		
Power consumption	< 125 mA (at 24 V without I/O modules) < 500 mA (at 24 V with I/O modules)			< 125 mA (at 24 V without I/O modules) < 500 mA (at 24 V with I/O modules)		
Insulation voltage	350 V AC, 50 Hz (system/supply)			350 V AC, 50 Hz (system/supply)		
Creepage distances and clearances	DIN EN 61131-2; DIN EN 50178			DIN EN 61131-2; DIN EN 50178		
Electrostatic discharge	EN 61000-4-2; 8 kV air; 4 kV contact			EN 61000-4-2; 8 kV air; 4 kV contact		
Electrostatic fields	ENV 50140; 10 V/m; 30...1000 MHz			ENV 50140; 10 V/m; 30...1000 MHz		
Interference immunity/emitted interference	EN 61000-6-2/EN 55011; limit value A; group 1			EN 61000-6-2/EN 55011; limit value A; group 1		
Burst	2 kV according to DIN EN 61000-4-4			2 kV according to DIN EN 61000-4-4		
Connection technology	Spring clamp terminal			Spring clamp terminal		
Wire range: fine-stranded/solid	0.14 mm ² – 1.5 mm ² /0.5 mm ² – 2.5 mm ²			0.14 mm ² – 1.5 mm ² /0.5 mm ² – 2.5 mm ²		
Ambient temperature	0 °C...+55 °C			0 °C...+55 °C		
Storage temperature	-25 °C...+75 °C			-25 °C...+75 °C		
Bus-specific status displays	RUN	green LED	RUN	RUN	green LED	RUN
	Status to master	green/red LED	NET	Network status	green/red LED	NET
	Ready for operation	green/red LED	MOD	Module status	green/red LED	MOD
	Operating voltage	green LED	5 V	Operating voltage	green LED	5 V
Accessories						
Bus connector		25.323.3501.0	50		25.323.3501.0	50
Manual, German		05.591.3389.0	1		05.591.3389.0	1
Manual, English		05.562.1389.0	1		05.562.1389.0	1
GSD file and Word document for labels		05.591.3255.0	1		05.591.3255.0	1
8 digit marking tag, blank		04.242.1553.0	500		04.242.1553.0	500
8 digit marking tag, with inscription (on request)						
End clamp for DIN rail		Z5.522.8553.0	100		Z5.522.8553.0	100

Remote I/O Bus couplers

ricos

Modular bus coupler with operating and display functionality for the following fieldbus:

- Ethernet Modbus TCP/IP



ricos BC-Ethernet
Ethernet Modbus TCP/IP bus coupler
Approvals: in preparation: CE

Dimensions (mm): W x H x D
74 x 92 x 51

Description	Type	Part No.	Std. Pack
Bus coupler with diagnostic functions	BC-Ethernet	83.034.0000.1	1
Display of operating modes:			
FORCE mode: yellow LED			
TRIGGER: yellow LED			
LOCK mode: yellow LED			
STOP mode: yellow LED			
RUN mode: green LED			
System data			
Maximum number of nodes	254 per network		
Transmission medium	100 Base-T4 or 100 Base-TX		
Maximum system expansion	100 m		
Baud rate	10/100 Mbit/s		
Internal bus refresh rate	2 ms		
Bus connection	RJ 45		
Technical data			
Maximum number of I/O bytes	64 E-Byte/64 A-Byte		
Number of I/O modules per node	8		
Number of digital I/O points per node	128		
Number of analogue I/O points per node	32		
Address setting	setting via keyboard		
Configuration	PC or PLC		
Operating voltage	24 V DC +20%, max. 5% residual ripple		
Power consumption	< 150 mA (< 3.5 W) (without I/O module)		
Insulation voltage	350 V AC / 50 Hz		
Creepage distances and clearances	DIN EN 61131-2; DIN EN 50178		
Electrostatic discharge	EN 61000-4-2; 8 kV air; 4 kV contact		
Electrostatic fields	ENV 50140; 10 V/m; 30 ... 1000 MHz		
Interference immunity/emitted interference	EN 61000-6-3 / EN 55011; limit value A; group 1		
Burst	2 kV according to DIN EN 61000-4-4		
Connection technology	Spring clamp terminal		
Wire range: fine-stranded/solid	0.14 – 1.5 mm ² / 0.5 – 2.5 mm ²		
Ambient temperature	0 °C ... +55 °C		
Storage temperature	-25 °C ... +70 °C		
Bus-specific status displays	RUN yellow LED RUN		
	Data exchange green LED TxD/RxD		
	Connection to network green LED LINK		
	Operating voltage yellow LED 5 V		
	Initialization red LED INIT		
Accessories			
Vertical bus connector			
Vertical bus connector			
Horizontal bus connector (being prepared)			
Manual, German	05.564.1589.0	1	
Manual, English	05.563.9289.0	1	
GSD file and Word document for labels	05.591.3255.0	1	
8 digit marking tag, blank	04.242.1553.0	500	
8 digit marking tag, with inscription (on request)			
End clamp for DIN rail	Z5.522.8553.0	100	

Remote I/O PLC with Ethernet fieldbus

ricos

Freely programmable PLC with Ethernet fieldbus:

- Programming according to EN 61131-3

Fieldbus:

- Ethernet Modbus TCP/IP



ricos BC-Ethernet PLC PLC with Ethernet Modbus TCP/IP

Approvals: in preparation: CE

Dimensions (mm): W x H x D

74 x 92 x 51

Description	Type	Part No.	Std. Pack	Other technical data
Bus coupler with diagnostic functions	BC-Ethernet PLC	83.034.0010.1	1	
Display of operating modes:				Download of operating system via Ethernet FT protocol
FORCE mode: yellow LED				Programming of CoDeSys via Ethernet TCP/IP
TRIGGER: yellow LED				Development environment
LOCK mode: yellow LED				
STOP mode: yellow LED				Extendable
RUN mode: green LED				max. 8 ricos I/O-Module all functions
System data				Program memory/ Data memory
Maximum number of nodes	254 per network			16 MB RAM available, minus firmware requirement, only
Transmission medium	CAT 5 twisted pair 10/100 base Tx			limited by size of user memory
Maximum system expansion	100 m			
Baud rate	10/100 MBaud (Ethernet coupler)			
Internal bus refresh rate	2 ms			Flash / Memory
Bus connection	RJ 45			1 MB for CoDeSys, PLC program
Technical data				Process image size, Program size, POU size, number of variables, only limited by size of user memory
Maximum number of I/O bytes	64 E-Byte/64 A-Byte			
Number of I/O modules per node	8			
Number of digital I/O points per node	128			
Number of analogue I/O points per node	32			
Address setting	Ethernet coupler			
Configuration	PC or PLC			EEPROM
Operating voltage	24 V DC +/-20%, max. 5% residual ripple			512 kBytes
Power consumption	< 150 mA (< 3.5 W) (without I/O module)			Controller
				NetARM40
Insulation voltage	350 V AC / 50 Hz			Execution time
Creepage distances and clearances	DIN EN 61131-2; DIN EN 50178			one PLC task
Electrostatic discharge	EN 61000-4-2; 8 kV air; 4 kV contact			Programming languages
Electrostatic fields	ENV 50140; 10 V/m; 30 ... 1000 MHz			IEC 61131-3: IL, FBD, LD, SFC, ST, CFC, AWL, FUL, KOP,
Interference immunity/emitted interference	EN 61000-6-3 / EN 55011; limit value A; group 1			C code can be incorporated, powerful library management
Burst	2 kV according to DIN EN 61000-4-4			
Connection technology	Spring clamp terminal			
Wire range: fine-stranded/solid	0.14 – 1.5 mm ² / 0.5 – 2.5 mm ²			
Ambient temperature	0 °C ... +55 °C			Times and counters
Storage temperature	-25 °C ... +70 °C			typically 10 ms
Bus-specific status displays	RUN	yellow LED	RUN	Times and counters
	Data exchange	green LED	TxD/RxD	600 μs (NETARM) for 1000 PLC commands
	Data exchange	green LED	LINK	
	Operating voltage	yellow LED	5 V	Times and counters
	Initialization	red LED	INIT	openly programmable / unlimited number
Accessories				
Vertical bus connector				Function modules
Vertical bus connector				Builder and Editor
Horizontal bus connector (being prepared)				Real-time clock and date
				not available
Manual, German		05.564.1589.0	1	
Manual, English		05.563.9289.0	1	
GSD file and Word document for labels		05.591.3255.0	1	
8 digit marking tag, blank		04.242.1553.0	500	
8 digit marking tag, with inscription (on request)				
End clamp for DIN rail		Z5.522.8553.0	100	

Remote I/O

Circuit diagrams for bus coupler PLC

Circuit diagrams for field bus couplers

PROFIBUS DP

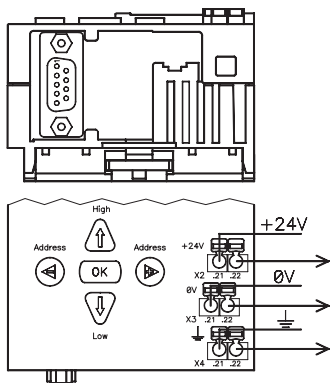

Interbus

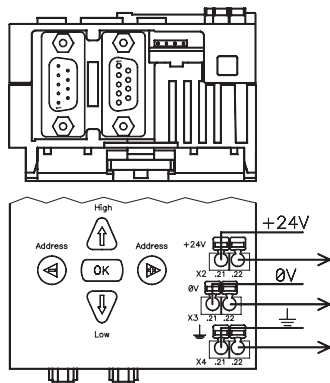

DeviceNet and CANopen

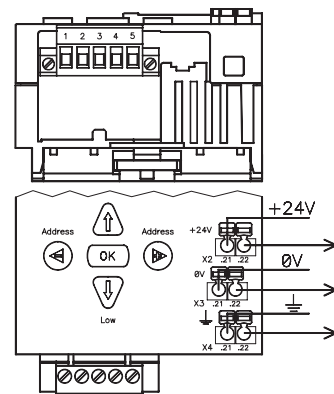

Modular bus coupler Ethernet Modbus TCP/IP

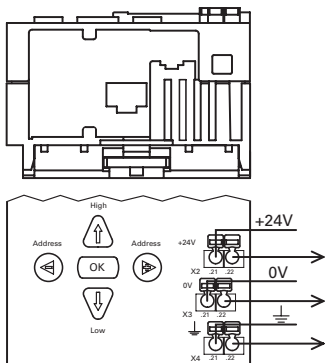

Remote I/O Bus couplers **ricos**

Modular economy bus couplers
for the following fieldbus systems:

- PROFIBUS DP
- Interbus



ricos EC-DP
PROFIBUS DP bus coupler
Approvals: us, Profibus certification

ricos EC-S
Interbus bus coupler
Approvals: us

Dimensions (mm): W x H x D
63 x 92 x 51

Description	Type	Part No.	Std. Pack	Type	Part No.	Std. Pack
Economy bus coupler	EC-DP	83.030.0001.1	1	EC-S	83.031.0001.1	1
Display of operating modes:	RUN – processor is running: yellow LED BF – no bus connection (Bus Fail): red LED DIA – diagnostics signal sent: red LED			RUN – processor is running: yellow LED RD – remotebus disabled: red LED RC – remotebus connected: green LED BA – bus access: green LED		
System data						
Maximum number of nodes	99 (or 126 in connection with slaves with higher addressing options)			256		
Transmission medium	Shielded copper cable 2 x 0.25 mm ² /AWG 23			Shielded copper cable 5 x 0.25 mm ² /AWG 23		
Maximum system expansion	100 m – 1200 m (dependent on baud rate/cable)			400 m (remote bus)		
Baud rate	9.6 kBaud...12 Mbaud			500 kBaud		
Internal bus refresh rate	2 ms			2 ms		
Bus connection	1 x D-SUB 9, female connector with shield			2 x D-SUB 9, female connector and plug with shield		
Technical data						
Maximum number of I/O bytes	64 E-Byte/64 A-Byte			20 E-Byte/20 A-Byte		
Number of I/O modules per node	8			8		
Number of digital I/O points per node	128			128		
Number of analogue I/O points per node	32			32		
Address setting	3...99 (switch)			automatic dependent on system		
Configuration	PC or PLC			PC or PLC		
Operating voltage	24 V DC, ±20 %, max. 5 % residual ripple			24 V DC, ±20 %, max. 5 % residual ripple		
Power consumption	< 125 mA (at 24 V without I/O modules) < 500 mA (at 24 V with I/O modules)			< 125 mA (at 24 V without I/O modules) < 500 mA (at 24 V with I/O modules)		
Insulation voltage	350 V AC, 50 Hz (system/supply)			350 V AC, 50 Hz (system/supply)		
Creepage distances and clearances	DIN EN 61131-2; DIN EN 50178			DIN EN 61131-2; DIN EN 50178		
Electrostatic discharge	EN 61000-4-2; 8 kV air; 4 kV contact			EN 61000-4-2; 8 kV air; 4 kV contact		
Electrostatic fields	ENV 50140; 10 V/m; 30...1000 MHz			ENV 50140; 10 V/m; 30...1000 MHz		
Interference immunity/emitted interference	EN 61000-6-2/EN 55011; limit value A; group 1			EN 61000-6-2/EN 55011; limit value A; group 1		
Burst	2 kV according to DIN EN 61000-4-4			2 kV according to DIN EN 61000-4-4		
Connection technology	Spring clamp terminal			Spring clamp terminal		
Wire range: fine-stranded/solid	0.14 mm ² – 1.5 mm ² /0.5 mm ² – 2.5 mm ²			0.14 mm ² – 1.5 mm ² /0.5 mm ² – 2.5 mm ²		
Ambient temperature	0 °C...+55 °C			0 °C...+55 °C		
Storage temperature	-25 °C...+75 °C			-25 °C...+75 °C		
Accessories						
Vertical bus connector		83.030.0010.0 (node)	1			
Vertical bus connector		83.030.0011.0 (terminator)	1			
Horizontal bus connector		83.030.0012.0 (switch)	1			
Manual, German		05.591.3389.0	1	05.591.3389.0		1
Manual, English		05.562.1389.0	1	05.562.1389.0		1
GSD file and Word document for labels		05.591.3255.0	1	05.591.3255.0		1
8 digit marking tag, blank		04.242.1553.0	500	04.242.1553.0		500
8 digit marking tag, with inscription (on request)						
End clamp for DIN rail		Z5.522.8553.0	100	Z5.522.8553.0		100

Remote I/O Bus couplers

ricos

Modular economy bus couplers
for the following fieldbus system:

- DeviceNet
- CANopen



ricos EC-DeviceNet
DeviceNet bus coupler

Approvals:



ricos EC-CANopen
CANopen bus coupler

Approvals:

Dimensions (mm): W x H x D
63 x 92 x 51

Description	Type	Part No.	Std. Pack	Type	Part No.	Std. Pack
Bus coupler with diagnostic functions	EC-DEVICENET	83.032.0001.1	1	EC-CANOPEN	83.033.0001.1	1
	incl.1 bus plug			incl.1 bus plug		
Display of operating modes:	RUN – processor is running: yellow LED			RUN – processor is running: yellow LED		
	NET – status display to master: green/red LED			NET – status display to master: green/red LED		
	MOD – Ready for operation: green/red LED			MOD – Ready for operation: green/red LED		
System data						
Maximum number of nodes	64 with Repeater			126		
Transmission medium	Shielded copper cable trunk line AWG 15, 18 Shielded copper cable drop line AWG 22, 24			Shielded copper cable 3 x 0.25 mm ² /AWG 23		
Maximum system expansion	100 m – 500 m (dependent on baud rate/cable)			100 m – 500 m (dependent on baud rate/cable)		
Baud rate	125/250/500 kBaud (DIP switch)			10 kBaud...1 MBaud (DIP switch)		
Internal bus refresh rate	2 ms			2 ms		
Bus connection	5 pole connector, screw			5 pole connector, screw		
Technical data						
Maximum number of I/O bytes	64 E-Byte/64 A-Byte			9 R-PDO's; 9 T-PDO's		
Number of I/O modules per node	8			6		
Number of digital I/O points per node	128			96		
Number of analogue I/O points per node	32			24		
Address setting (MAC ID)	1...63 (via DIP switch)			1...126 (via DIP switch)		
Configuration	PC or PLC			PC or SPS		
Operating voltage	24 V DC, ±20 %, max. 5 % residual ripple			24 V DC, ±20 %, max. 5 % residual ripple		
Power consumption	< 125 mA (at 24 V without I/O modules) < 500 mA (at 24 V with I/O modules)			< 125 mA (at 24 V without I/O modules) < 500 mA (at 24 V with I/O modules)		
Insulation voltage	350 V AC, 50 Hz (system/supply)			350 V AC, 50 Hz (system/supply)		
Creepage distances and clearances	DIN EN 61131-2; DIN EN 50178			DIN EN 61131-2; DIN EN 50178		
Electrostatic discharge	EN 61000-4-2; 8 kV air; 4 kV contact			EN 61000-4-2; 8 kV air; 4 kV contact		
Electrostatic fields	ENV 50140; 10 V/m; 30...1000 MHz			ENV 50140; 10 V/m; 30...1000 MHz		
Interference immunity/emitted interference	EN 61000-6-2/EN 55011; limit value A; group 1			EN 61000-6-2/EN 55011; limit value A; group 1		
Burst	2 kV according to DIN EN 61000-4-4			2 kV according to DIN EN 61000-4-4		
Connection technology	Spring clamp terminal			Spring clamp terminal		
Wire range: fine-stranded/solid	0.14 mm ² – 1.5 mm ² /0.5 mm ² – 2.5 mm ²			0.14 mm ² – 1.5 mm ² /0.5 mm ² – 2.5 mm ²		
Ambient temperature	0 °C...+55 °C			0 °C...+55 °C		
Storage temperature	-25 °C...+75 °C			-25 °C...+75 °C		
Accessories						
Bus connector		25.323.3501.0	50		25.323.3501.0	50
Manual, German		05.591.3389.0	1		05.591.3389.0	1
Manual, English		05.562.1389.0	1		05.562.1389.0	1
GSD file and Word document for labels		05.591.3255.0	1		05.591.3255.0	1
8 digit marking tag, blank		04.242.1553.0	500		04.242.1553.0	
8 digit marking tag, with inscription (on request)						
End clamp for DIN rail		Z5.522.8553.0	100		Z5.522.8553.0	100

Remote I/O Binary I/O modules

ricos

- Individual parameterization as input or output with 8 I/O
- For 2, 3 and 4 wire connection
- Electronics can be replaced without disconnection of the wiring



Dimensions (mm): W x H x D
69 x 92 x 51

ricos 8 I/O
8 inputs or 8 outputs 24 V DC
Approvals:

ricos 16 I
16 inputs 24 V DC
Approvals:

Description	Type	Part No.	Std. Pack	Type	Part No.	Std. Pack
	ricos 8 I/O	83.035.3100.1	1	ricos 16 I	83.035.3000.1	1
Display of operating modes:						
24 V – power supply connected: yellow LED						
RUN – internal data transmission is running: yellow LED						
Channel LED – switching state: green LED						
Channel LED – channel cursor: yellow LED						
Module data						
Number of inputs	maximal 8			16		
Number of outputs	maximal 8			0		
Operating voltage	24 V DC, ±20 %, max. 5 % residual ripple			24 V DC, ±20 %, max. 5 % residual ripple		
Power consumption	< 0.5 W			< 0.5 W		
Configuration	None required			None required		
Memory space required by the control	2 input bytes/2 output bytes			2 input bytes		
Input data						
Switching level "0" (EN 61131-2)	-30 V...+5 V DC			-30 V...+5 V DC		
Switching level "1" (EN 61131-2)	+15 V...+30 V DC			+15 V...+30 V DC		
Input current/channel (at 24 V DC)	6.1 mA			4.5 mA		
Status display	green LED			green LED		
Output data						
Output voltage	Operating voltage – 0.5 V DC					
Output current per channel	1 A DC					
Maximum total current per module	8 A DC					
Concurrence	100 %					
Load types	resistive, inductive					
Status display	green LED					
Output behavior	Resistant to overload and short circuits					
General						
Signal delay per I/O channel	< 100 µs			< 100 µs		
Maximum voltage of power contact	30 V DC			30 V DC		
Maximum current of power contact	8 A DC			8 A DC		
Insulation voltage	350 V AC, 50 Hz (system/supply)			350 V AC, 50 Hz (system/supply)		
Creepage distances and clearances	DIN EN 61131-2; DIN EN 50178			DIN EN 61131-2; DIN EN 50178		
Electrostatic discharge	EN 61000-4-2; 8 kV air; 4 kV contact			EN 61000-4-2; 8 kV air; 4 kV contact		
Electrostatic fields	ENV 50140; 10 V/m; 30...1000 MHz			ENV 50140; 10 V/m; 30...1000 MHz		
Interference immunity/emitted interference	EN 61000-6-2/EN 55011; limit value A; group 1			EN 61000-6-2/EN 55011; limit value A; group 1		
Burst	according to EN 61000-4-4			according to EN 61000-4-4		
Connection technology	Spring clamp terminal			Spring clamp terminal		
Wire range: fine-stranded/solid	0.14 mm ² – 1.5 mm ² /0.5 mm ² – 2.5 mm ²			0.14 mm ² – 1.5 mm ² /0.5 mm ² – 2.5 mm ²		
Ambient temperature	0 °C...+55 °C			0 °C...+55 °C		
Storage temperature	-25 °C...+75 °C			-25 °C...+75 °C		
Accessories						
Snap-on distribution board 3 and 4 wire operation		83.039.0000.0	1		83.039.0000.0	1
Adhesive labels, A4 sheet		05.591.3089.0	10		05.591.3089.0	10
2 pole jumper for parallel connection of outputs		Z7.258.1225.0	10		Z7.258.1225.0	10
8 digit marking tag, blank		04.242.1553.0	500		04.242.1553.0	500
8 digit marking tag, with inscription (on request)						
End clamp for DIN rail		Z5.522.8553.0	100		Z5.522.8553.0	100

Remote I/O Binary I/O modules

ricos

Alternating current input modules
for 115 V and 230 V



ricos 4I AC 115 V
4 inputs 115 V AC
Approvals: cULus



ricos 4I AC 230 V
4 inputs 230 V AC
Approvals: cULus

Dimensions (mm): W x H x D
69 x 92 x 51

Description	Type	Part No.	Std. Pack	Type	Part No.	Std. Pack
	ricos 4I AC 115 V	83.035.5000.1	1	ricos 4I AC 230 V	83.035.5005.1	1
Display of operating modes:						
24 V – power supply connected: yellow LED						
RUN – internal data transmission is running: yellow LED						
Channel LED – switching state: green LED						
Channel LED – channel cursor: yellow LED						
Module data						
Number of inputs	4			4		
Number of outputs	0			0		
Operating voltage	115 V AC, ± 10 %			230 V AC, ± 10 %		
Power consumption	< 0.5 W			< 0.5 W		
Configuration	None required			None required		
Memory space required by the control	1 input byte			1 input byte		
Input data						
Switching level "0" (EN 61131-2)	0 V...20 V AC			0 V...40 V AC		
Switching level "1" (EN 61131-2)	79 V...130 V AC			164 V...250 V AC		
Input current/channel (at 24 V DC)	typically 5 mA			typically 5 mA		
Status display	green LED			green LED		
Output data						
Output voltage						
Output current per channel						
Maximum total current per module						
Concurrence						
Load types						
Status display						
Output behavior						
General						
Signal delay per I/O channel	max. 10 ms			max. 10 ms		
Maximum voltage of power contact	250 V AC			250 V AC		
Maximum current of power contact	8 A AC			8 A AC		
Insulation voltage	350 V AC, 50 Hz (system/supply)			350 V AC, 50 Hz (system/supply)		
Creepage distances and clearances	DIN EN 61131-2; DIN EN 50178			DIN EN 61131-2; DIN EN 50178		
Electrostatic discharge	EN 61000-4-2; 8 kV air; 4 kV contact			EN 61000-4-2; 8 kV air; 4 kV contact		
Electrostatic fields	ENV 50140; 10 V/m; 30...1000 MHz			ENV 50140; 10 V/m; 30...1000 MHz		
Interference immunity/emitted interference	EN 61000-6-2/EN 55011; limit value A; group 1			EN 61000-6-2/EN 55011; limit value A; group 1		
Burst	according to EN 61000-4-4			according to EN 61000-4-4		
Connection technology	Spring clamp terminal			Spring clamp terminal		
Wire range: fine-stranded/solid	0.14 mm ² – 1.5 mm ² /0.5 mm ² – 2.5 mm ²			0.14 mm ² – 1.5 mm ² /0.5 mm ² – 2.5 mm ²		
Ambient temperature	0 °C...+55 °C			0 °C...+55 °C		
Storage temperature	-25 °C...+75 °C			-25 °C...+75 °C		
Accessories						
Snap-on distribution board 3 and 4 wire operation		83.039.0000.0	1		83.039.0000.0	1
Adhesive labels, A4 sheet		05.591.3089.0	10		05.591.3089.0	10
2 pole jumper for parallel connection of outputs		Z7.258.1225.0	10		Z7.258.1225.0	10
8 digit marking tag, blank		04.242.1553.0	500		04.242.1553.0	500
8 digit marking tag, with inscription (on request)						
End clamp for DIN rail		Z5.522.8553.0	100		Z5.522.8553.0	100

Remote I/O Circuit diagrams

ricos

Circuit diagrams for binary input modules

ricos 8I/O

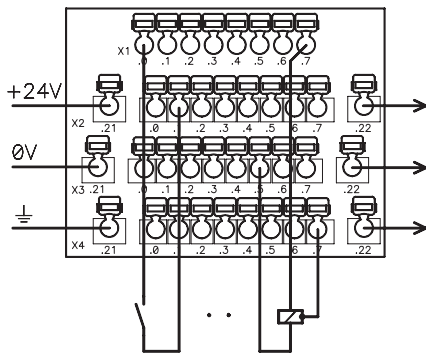

ricos 16I

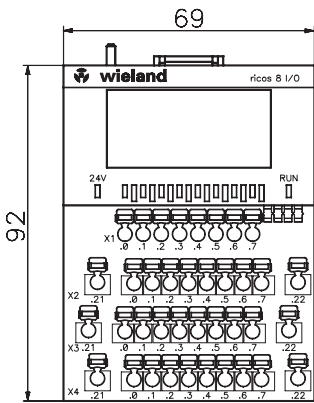
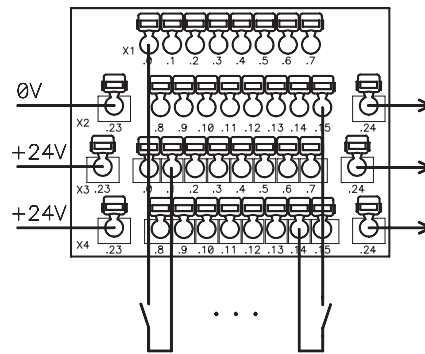

Derating

Total current

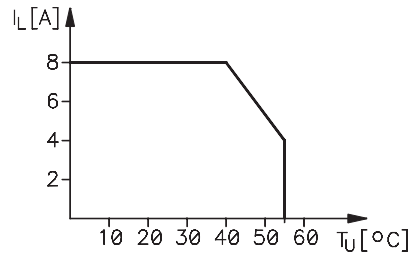

ricos 4I 115 V

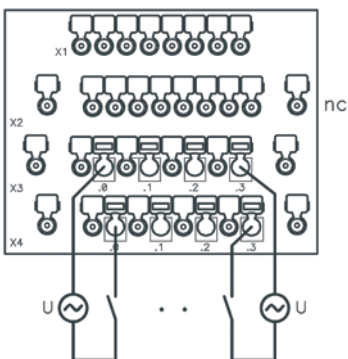

ricos 4I 230 V

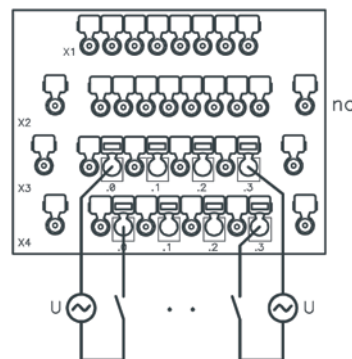

Remote I/O Binary I/O modules

ricos

- Parameterization as input or output with 8 I, 8 I/O
- For 2, 3 and 4 wire connection
- Electronics can be replaced without disconnection of the wiring



ricos 16O
16 outputs 24 V DC
Approvals: cULus



ricos 8I 8I/O
8 inputs and 8 inputs/outputs 24 V DC
Approvals: cULus

Dimensions (mm): W x H x D
69 x 92 x 51

Description	Type	Part No.	Std. Pack	Type	Part No.	Std. Pack
	ricos 16O	83.035.3200.1	1	ricos 8I 8I/O	83.035.3300.1	1
Display of operating modes:						
24 V – power supply connected: yellow LED						
RUN – internal data transmission is running: yellow LED						
Channel LED – switching state: green LED						
Channel LED – channel cursor: yellow LED						
Module data						
Number of inputs	0			8 + maximal 8		
Number of outputs	16			maximal 8		
Operating voltage	24 V DC, ±20 %, max. 5 % residual ripple			24 V DC, ±20 %, max. 5 % residual ripple		
Power consumption	< 0.5 W			< 0.5 W		
Configuration	None required			None required		
Memory space required by the control	2 output byte			2 input bytes and 2 output byte		
Input data						
Switching level "0" (EN 61131-2)				-30 V...+5 V DC		
Switching level "1" (EN 61131-2)				+15 V...+30 V DC		
Input current/channel (at 24 V DC)				4.5 mA/6.5 mA (Combi I/O)		
Status display				green LED		
Output data						
Output voltage	Operating voltage – 0.5 V DC			Operating voltage –0.5 V DC		
Output current per channel	1 A DC			1 A DC		
Maximum total current per module	8 A DC			8 A DC		
Concurrence	50 %			100 %		
Load types	resistive inductive			resistive inductive		
Status display	green LED			green LED		
Output behavior	Resistant to overload and short circuits			Resistant to overload and short circuits		
General						
Signal delay per I/O channel	< 100 µs			< 100 µs		
Maximum voltage of power contact	30 V DC			30 V DC		
Maximum current of power contact	8 A DC			8 A DC		
Insulation voltage	350 V AC, 50 Hz (system/supply)			350 V AC, 50 Hz (system/supply)		
Creepage distances and clearances	DIN EN 61131-2; DIN EN 50178			DIN EN 61131-2; DIN EN 50178		
Electrostatic discharge	EN 61000-4-2; 8 kV air; 4 kV contact			EN 61000-4-2; 8 kV air; 4 kV contact		
Electrostatic fields	ENV 50140; 10 V/m; 30...1000 MHz			ENV 50140; 10 V/m; 30...1000 MHz		
Interference immunity/emitted interference	EN 61000-6-2/EN 55011; limit value A; group 1			EN 61000-6-2/EN 55011; limit value A; group 1		
Burst	according to EN 61000-4-4			according to EN 61000-4-4		
Connection technology	Spring clamp terminal			Spring clamp terminal		
Wire range: fine-stranded/solid	0.14 mm ² – 1.5 mm ² /0.5 mm ² – 2.5 mm ²			0.14 mm ² – 1.5 mm ² /0.5 mm ² – 2.5 mm ²		
Ambient temperature	0 °C...+55 °C			0 °C...+55 °C		
Storage temperature	-25 °C...+75 °C			-25 °C...+75 °C		
Accessories						
Snap-on distribution board 3 and 4 wire operation		83.039.0000.0	1	83.039.0000.0	1	
Adhesive labels, A4 sheet		05.591.3089.0	10	05.591.3089.0	10	
2 pole jumper for parallel connection of outputs		Z7.258.1225.0	10	Z7.258.1225.0	10	
8 digit marking tag, blank		04.242.1553.0	500	04.242.1553.0	500	
8 digit marking tag, with inscription (on request)						
End clamp for DIN rail		Z5.522.8553.0	100	Z5.522.8553.0	100	

Remote I/O Binary I/O modules

ricos

- For 2, 3 and 4 wire connection
- Electronics can be replaced without disconnection of the wiring



ricos 80 DC 2A
8 outputs 24 V DC 2 A
Approvals:

ricos 80 NEG
8 outputs 24 V DC neg. switching
Approvals:

Dimensions (mm): W x H x D
69 x 92 x 51

Description	Type	Part No.	Std. Pack	Type	Part No.	Std. Pack
	ricos 80 DC 2A	83.035.3220.1	1	ricos 80 NEG	83.035.3210.1	1
Display of operating modes:						
24 V – power supply connected: yellow LED						
RUN – internal data transmission is running: yellow LED						
Channel LED – switching state: green LED						
Channel LED – channel cursor: yellow LED						
Module data						
Number of inputs	0			0		
Number of outputs	8			8		
Operating voltage	24 V DC, ±20 %, max. 5 % residual ripple			24 V DC, ±20 %, max. 5 % residual ripple		
Power consumption	< 0.5 W			< 0.5 W		
Configuration	None required			None required		
Memory space required by the control	2 Output bytes (byte 2 is not occupied)			2 Output bytes (byte 2 is not occupied)		
Input data						
Switching level "0" (EN 61131-2)						
Switching level "1" (EN 61131-2)						
Input current/channel (at 24 V DC)						
Status display						
Output data						
Output voltage	Operating voltage –0.5 V DC			Operating voltage –0.5 V DC		
Output current per channel	2 A DC			1 A DC		
Maximum total current per module	8 A DC			8 A DC		
Concurrence	100 % (note max. total current)			100 %		
Load types	resistive, inductive			resistive, inductive		
Status display	green LED			green LED		
Output behavior	Resistant to overload and short circuits			Resistant to overload and short circuits		
General						
Signal delay per I/O channel	< 100 µs			< 100 µs		
Maximum voltage of power contact	30 V DC			30 V DC		
Maximum current of power contact	8 A DC			8 A DC		
Insulation voltage	350 V AC, 50 Hz (system/supply)			350 V AC, 50 Hz (system/supply)		
Creepage distances and clearances	DIN EN 61131-2; DIN EN 50178			DIN EN 61131-2; DIN EN 50178		
Electrostatic discharge	EN 61000-4-2; 8 kV air; 4 kV contact			EN 61000-4-2; 8 kV air; 4 kV contact		
Electrostatic fields	ENV 50140; 10 V/m; 30...1000 MHz			ENV 50140; 10 V/m; 30...1000 MHz		
Interference immunity/emitted interference	EN 61000-6-2/EN 55011; limit value A; group 1			EN 61000-6-2/EN 55011; limit value A; group 1		
Burst	according to EN 61000-4-4			according to EN 61000-4-4		
Connection technology	Spring clamp terminal			Spring clamp terminal		
Wire range: fine-stranded/solid	0.14 mm ² – 1.5 mm ² /0.5 mm ² – 2.5 mm ²			0.14 mm ² – 1.5 mm ² /0.5 mm ² – 2.5 mm ²		
Ambient temperature	0 °C...+55 °C			0 °C...+55 °C		
Storage temperature	–25 °C...+75 °C			–25 °C...+75 °C		
Accessories						
Snap-on distribution board 3 and 4 wire operation		83.039.0000.0	1		83.039.0000.0	1
Adhesive labels, A4 sheet		05.591.3089.0	10		05.591.3089.0	10
2 pole jumper for parallel connection of outputs		Z7.258.1225.0	10		Z7.258.1225.0	10
8 digit marking tag, blank		04.242.1553.0	500		04.242.1553.0	500
8 digit marking tag, with inscription (on request)						
End clamp for DIN rail		Z5.522.8553.0	100		Z5.522.8553.0	100

Remote I/O Digital I/O modules

ricos

- Can be configured as input or output for 2, 3 and 4 wire connection
- Electronics can be replaced without disconnection of the wiring



ricos 40 RELAY

4 relay outputs

Approvals: US

Dimensions (mm): W x H x D

69 x 92 x 51

Description	Type	Part No.	Std. Pack
	ricos 40 RELAY	83.035.5200.1	1
Display of operating modes:			
24 V – power supply connected: yellow LED			
RUN – internal data transmission is running: yellow LED			
Channel LED – switching state: green LED			
Channel LED – channel cursor: yellow LED			
Module data			
Number of inputs	0		
Number of outputs	4		
Operating voltage	24 V DC, ±20 %, max. 5 % residual ripple		
Power consumption	< 1 W		
Configuration	None required		
Memory space required by the control	1 output byte		
Input data			
Switching level "0" (EN 61131-2)			
Switching level "1" (EN 61131-2)			
Input current/channel (at 24 V DC)			
Status display			
Output data			
Output voltage	250 V AC, 30 V DC		
Output current per channel	2 A AC/DC		
Maximum total current per module	8 A AC/DC		
Concurrence	100 %		
Load types	resistive/inductive		
Status display	green LED		
Output behavior			
General			
Signal delay per I/O channel	< 10 ms		
Maximum voltage of power contact	250 V AC/DC		
Maximum current of power contact	8 A AC/DC		
Insulation voltage	350 V AC, 50 Hz (system/supply)		
Creepage distances and clearances	DIN EN 61131-2; DIN EN 50178		
Electrostatic discharge	EN 61000-4-2; 8 kV air; 4 kV contact		
Electrostatic fields	ENV 50140; 10 V/m; 30...1000 MHz		
Interference immunity/emitted interference	EN 61000-6-2/EN 55011; limit value A; group 1		
Burst	according to EN 61000-4-4		
Connection technology	Spring clamp terminal		
Wire range: fine-stranded/solid	0.14 mm ² – 1.5 mm ² /0.5 mm ² – 2.5 mm ²		
Ambient temperature	0 °C...+55 °C		
Storage temperature	-25 °C...+75 °C		
Accessories			
Snap-on distribution board 3 and 4 wire operation		83.039.0000.0	1
Adhesive labels, A4 sheet		05.591.3089.0	10
2 pole jumper for parallel connection of outputs		Z7.258.1225.0	10
8 digit marking tag, blank		04.242.1553.0	500
8 digit marking tag, with inscription (on request)			
End clamp for DIN rail		Z5.522.8553.0	100

Remote I/O

RS 232 / RS 485 modules

ricos

- RS 232 and RS 485 interface
- 300...38400 Baud
- Electronics can be replaced without disconnection of the wiring



ricos RS 232/485

Interface Module RS 232 / RS 485

Approvals:  in preparation: CE

Dimensions (mm): W x H x D
69 x 92 x 51

Description	Type	Part No.	Std. Pack
	ricos RS 232/RS 485	83.035.5420.1	1
Display of operating modes:			
Ready for operation RUN:	yellow LED		
Power supply OK:	yellow LED		
RTS, CTS:	green LED		
RxD, TxD:	green LED		
Module data			
Interfaces	RS 232, RS 485		
Buffer memory	128 Byte in; 16 Byte out		
Transmission length	15 m (RS 232); 500 m twisted pair (RS 485)		
Transmission rate	300, 600, 1200, 2400, 4800, 9600, 19200, 38400 Baud		
Bit transfer	ISO 8482 / DIN 66259-4		
Internal data width	10 Byte		
Input data			
Power supply	24 V DC, ±20% max. 5% residual ripple		
Power consumption	max. 30 mA		
Over voltage protection	Suppressor diode		
Supply (from bus coupler) 5V			
Power consumption	approx. 23 mA / approx. 0.55 W		
Output data			
Signal delay of input/output	< 1 µs / < 300 µs		
Maximum voltage of power contacts	30 V DC		
Maximum current of power contacts	8 A DC		
Insulation voltage	350 V AC, 50 Hz (system/supply)		
Creepage distances and clearances	DIN EN 61131-2; DIN EN 50178		
Electrostatic discharge	EN 61000-4-2; 8 kV air; 4 kV contact		
Electrostatic fields	ENV 50140; 10 V/m; 30...1000 MHz		
Interference immunity/emitted interference	EN 61000-6-2 / EN 55011; limit value A; group 1		
Burst	according to EN 61000-4-4		
Connection technology	Spring clamp terminal		
Wire range: fine-stranded/solid	0.14 mm ² – 1.5 mm ² / 0.5 mm ² – 2.5 mm ²		
Ambient temperature	0 °C...+55 °C		
Storage temperature	-25 °C...+70 °C		
Accessories			
Snap-on distribution board 3 and 4 wire operation		83.039.0000.0	1
Adhesive labels, A4 sheet		05.591.3255.0	1
2 pole jumper for parallel connection of outputs		Z7.258.1225.0	10
8 digit marker tag, blank		04.242.1553.0	500
8 digit marker tag, with inscription (on request)			
End clamp for DIN rail		Z5.522.8553.0	100

Circuit diagrams for binary output modules

ricos 160

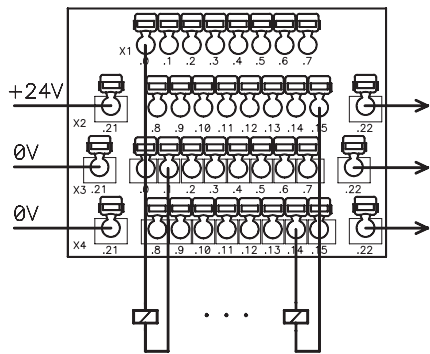

ricos 8I 8I/O

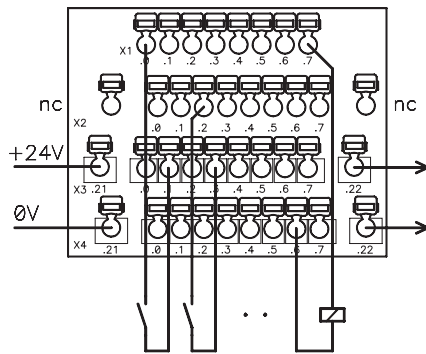

ricos RS 232/RS 485

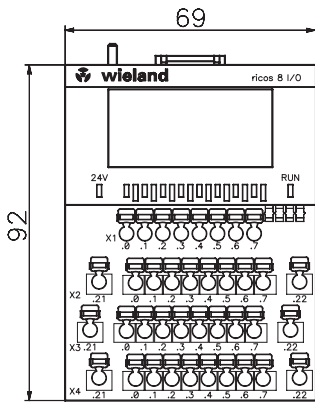
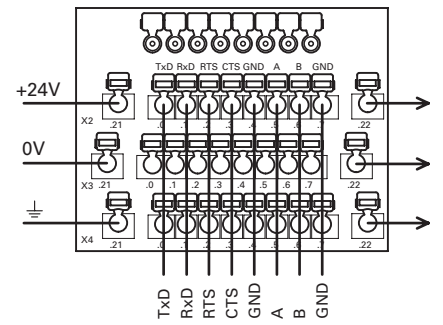

Derating

Total current

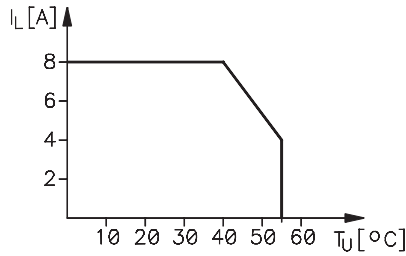

ricos 40 RELAY

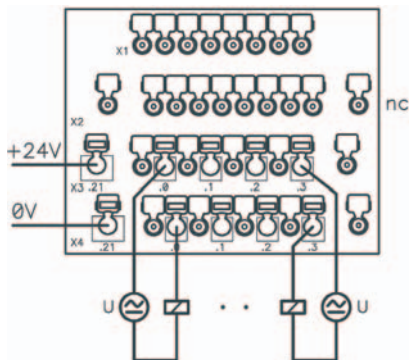

ricos 80 2A

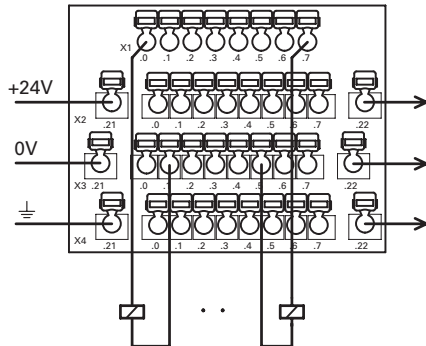

ricos 80 NEG

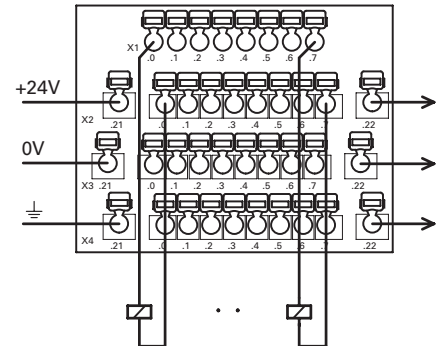

Remote I/O Counter/positioning modules

ricos

- 2 or 4 counters per module
- Up to 2 threshold values can be set
- Positioning modules for 2 axes
- Electronics can be replaced without disconnection of the wiring



ricos COUNTER
2/4 fold counter
Approvals:



ricos POSITION
Positioning module with incremental encoder inputs
Approvals:

Dimensions (mm): W x H x D
69 x 92 x 51

Description	Type	Part No.	Std. Pack	Type	Part No.	Std. Pack
	ricos COUNTER	83.035.5400.1	1	ricos POSITION	83.035.5410.1	1
Display of operating modes:						
24 V – power supply connected: yellow LED						
RUN – internal data transmission is running: yellow LED						
Channel LED – switching state: green LED						
Channel LED – channel cursor: yellow LED						
Module data						
Number of ...	Counter: 4 x 16 Bit or 2 x 32 Bit			Controllable axes: 2		
Counting range	0 to 2 ¹⁶ or 0 to 2 ³²			-2 ³¹ to 2 ³¹ -1		
Number of inputs and outputs	12/4 or 6/4			10/6		
Counting frequency	200 Hz, 2 kHz, 20 kHz, 200 kHz adjustable			maximal 200 kHz		
Configuration	via PC or PLC			via PC or PLC		
Memory space required by the control	3 to 5 words			5 words		
Input data						
Switching level "0" (EN 61131-2)	-30 V...+5 V DC			-30 V...+5 V DC		
Switching level "1" (EN 61131-2)	+15 V...+30 V DC			+15 V...+30 V DC		
Input current/channel (at 24 V DC)	7.5 mA			7.5 mA		
Status display	green LED			green LED		
Output data						
Output voltage	Operating voltage -0.5 V DC			Operating voltage -0.5 V DC		
Output current per channel	1 A DC			1 A DC		
Maximum total current per module	4 A DC			6 A DC		
Concurrence	100 %			100 %		
Load types	resistive, inductive			resistive, inductive		
Status display	LED green			green LED		
Output behavior	Resistant to overload and short circuits			Resistant to overload and short circuits		
Operating voltage/Power consumption	24 V DC, ±20 %, max. 5 % residual ripple/< 3 W			24 V DC, ±20 %, max. 5 % Residual ripple/< 3 W		
General						
Operating voltage/power consumption	< 1 μs/< 300 μs			< 100 μs		
Maximum voltage of power contact	30 V DC			30 V DC		
Maximum current of power contact	8 A DC			8 A DC		
Insulation voltage	350 V AC, 50 Hz (system/supply)			350 V AC, 50 Hz (system/supply)		
Creepage distances and clearances	DIN EN 61131-2; DIN EN 50178			DIN EN 61131-2; DIN EN 50178		
Electrostatic discharge	EN 61000-4-2; 8 kV air; 4 kV contact			EN 61000-4-2; 8 kV air; 4 kV contact		
Electrostatic fields	ENV 50140; 10 V/m; 30...1000 MHz			ENV 50140; 10 V/m; 30...1000 MHz		
Interference immunity/emitted interference	EN 61000-6-2/EN 55011; limit value A; group 1			EN 61000-6-2/EN 55011; limit value A; group 1		
Burst	according to EN 61000-4-4			according to EN 61000-4-4		
Connection technology	Spring clamp terminal			Spring clamp terminal		
Wire range: fine-stranded/solid	0.14 mm ² – 1.5 mm ² /0.5 mm ² – 2.5 mm ²			0.14 mm ² – 1.5 mm ² /0.5 mm ² – 2.5 mm ²		
Ambient temperature	0 °C...+55 °C			0 °C...+55 °C		
Storage temperature	-25 °C...+75 °C			-25 °C...+75 °C		
Accessories						
Snap-on distribution board 3 and 4 wire operation		83.039.0000.0	1		83.039.0000.0	1
Adhesive labels, A4 sheet		05.591.3089.0	10		05.591.3089.0	10
2 pole jumper for parallel connection of outputs		Z7.258.1225.0	10		Z7.258.1225.0	10
8 digit marking tag, blank		04.242.1553.0	500		04.242.1553.0	500
8 digit marking tag, with inscription (on request)						
End clamp for DIN rail		Z5.522.8553.0	100		Z5.522.8553.0	100

Circuit diagrams for counter and positioning modules

ricos COUNTER

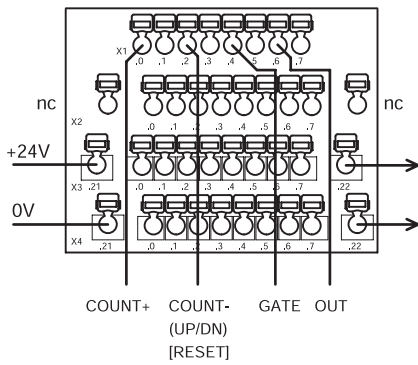

ricos POSITION

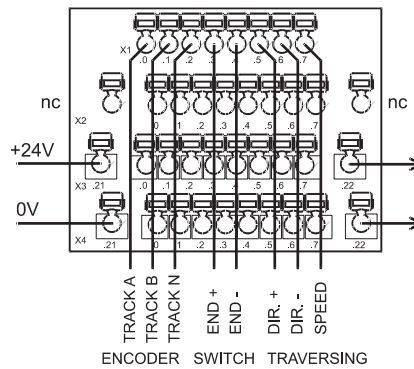

Circuit diagrams for Pt100 and TC modules

ricos 4AI Pt100

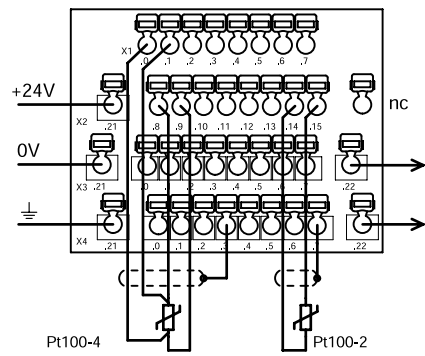

ricos 4AI TC

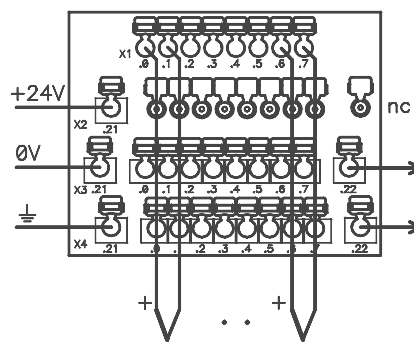

Remote I/O Analog I/O modules

ricos

- For default signals 0...10 V / ± 10 V
- For 2, 3 and 4 wire connection
- Electronics can be replaced without disconnection of the wiring



ricos 4AI/0...10 V
4 inputs 0 to 10 V

Approvals:



ricos 4AI/±10 V
4 inputs ±10 V

Approvals:

Dimensions (mm): W x H x D
69 x 92 x 51

Description	Type	Part No.	Std. Pack	Type	Part No.	Std. Pack
Display of operating modes:	ricos 4AI/0...10 V	83.035.4001.1	1	ricos 4AI/±10 V	83.035.4000.1	1
24 V – power supply connected: yellow LED						
RUN – internal data transmission is running: yellow LED						
Channel LED – switching state: green LED						
Channel LED – channel cursor: yellow LED						
Module data						
Number of inputs	4			4		
Number of outputs	0			0		
Operating voltage	24 V DC, ±20%, max. 5% residual ripple			24 V DC, ±20%, max. 5% residual ripple		
Power consumption	< 2.5 W			< 2.5 W		
Configuration	PC, PLC, diagnostics code 9 bus coupler			PC, PLC, diagnostics code 9 bus coupler		
Memory space required by the control	1 to 4 input words (dependent on configuration)			1 to 4 input words (dependent on configuration)		
Technical data						
Measuring range	0...+9.995 V			-10...+9.995 V		
Resolution	12 Bit			12 Bit		
Scanning frequency	< 2 ms			< 2 ms		
Offset error	typ. 0.5 LSB; max. 1 LSB			typ. 0.5 LSB; max. 1 LSB		
Channel crosstalk	-74 dB (f < 100 Hz)			-74 dB (f < 100 Hz)		
Gain error	typ. 0.08% FSR; max. 0.2% FSR			typ. 0.08% FSR; max. 0.2% FSR		
Noise voltage	typ. 0.5 LSB; max. 2 LSB			typ. 0.5 LSB; max. 2 LSB		
Offset error via source impedance	+3 LSB/kOhm (Uinput. = 0 V)			+3 LSB/kOhm (Uinput. = 0 V)		
Electrical isolation	75 V (AGND/Shield)			75 V (AGND/Shield)		
Common-mode range	+12.8 V DC			-12.8 V/+ 12.8 V DC		
Input resistance	1 MOhm			1 MOhm		
Input current	typ. 15 µA			typ. 15 µA		
Short circuit current/short circuit duration	-			-		
Ripple	-			-		
Voltage range for two-way detection of wire breakage	9.9 V (floating source)			-10 V/9.9 V (floating source)		
Common-mode rejection	87 dB (f = DC); 70 dB (f = 50 Hz); 60 dB (f = 1 kHz)			87 dB (f = DC); 70 dB (f = 50 Hz); 60 dB (f = 1 kHz)		
Common-mode input resistance	500 kOhm (inputs short-circuited to AGND)			500 kOhm (inputs short-circuited to AGND)		
Capacitive common-mode input resistance	4.4 nF (inputs short-circuited to AGND)			4.4 nF (inputs short-circuited to AGND)		
Dynamic common-mode input resistance	1.1 kOhm (f > 100 kHz)			1.1 kOhm (f > 100 kHz)		
Insulation voltage	350 V AC, 50 Hz (system/supply)			350 V AC, 50 Hz (system/supply)		
Creepage distances and clearances	DIN EN 61131-2; DIN EN 50178			DIN EN 61131-2; DIN EN 50178		
Electrostatic discharge	EN 61000-4-2; 8 kV air; 4 kV contact			EN 61000-4-2; 8 kV air; 4 kV contact		
Electrostatic fields	ENV 50140; 10 V/m; 30...1000 MHz			ENV 50140; 10 V/m; 30...1000 MHz		
Interference immunity/emitted interference	EN 61000-6-2/EN 55011; limit value A; group 1			EN 61000-6-2/EN 55011; limit value A; group 1		
Burst	according to EN 61000-4-4			according to EN 61000-4-4		
Connection technology	Spring clamp terminal			Spring clamp terminal		
Wire range: fine-stranded/solid	0.14 mm ² – 1.5 mm ² /0.5 mm ² – 2.5 mm ²			0.14 mm ² – 1.5 mm ² /0.5 mm ² – 2.5 mm ²		
Ambient temperature	0 °C...+55 °C			0 °C...+55 °C		
Storage temperature	-25 °C...+75 °C			-25 °C...+75 °C		
Accessories						
Snap-on distribution board 3 and 4 wire operation		83.039.0000.0	1		83.039.0000.0	1
Adhesive labels, A4 sheet		05.591.3089.0	10		05.591.3089.0	10
2 pole jumper for parallel connection of outputs		Z7.258.1225.0	10		Z7.258.1225.0	10
8 digit marking tag, blank		04.242.1553.0	500		04.242.1553.0	500
8 digit marking tag, with inscription (on request)						
End clamp for DIN rail		Z5.522.8553.0	100		Z5.522.8553.0	100

Remote I/O Analog I/O modules

ricos

- For default signals 0...10 V or ± 10 V
- For 2, 3 and 4 wire connection
- Electronics can be replaced without disconnection of the wiring



ricos 4AI4AO/0...10 V
4 inputs and 4 outputs 0 to 10 V
Approvals:



ricos 4AI4AO/±10 V
4 inputs and 4 outputs ± 10 V
Approvals:

Dimensions (mm): W x H x D
69 x 92 x 51

Description	Type	Part No.	Std. Pack	Type	Part No.	Std. Pack
Display of operating modes:	ricos 4AI4AO/0...10 V	83.035.4101.1	1	ricos 4AI4AO/±10 V	83.035.4100.1	1
24 V – power supply connected: yellow LED						
RUN – internal data transmission is running: yellow LED						
Channel LED – switching state: green LED						
Channel LED – channel cursor: yellow LED						
Module data						
Number of inputs	4			4		
Number of outputs	4			4		
Operating voltage	24 V DC, $\pm 20\%$, max. 5 % residual ripple			24 V DC, $\pm 20\%$, max. 5 % residual ripple		
Power consumption	< 2.5 W			< 2.5 W		
Configuration	PC, PLC, diagnostics code 9 bus coupler			PC, PLC, diagnostics code 9 bus coupler		
Memory space required by the control	1 to 4 input/output words (dependent on configuration)			1 to 4 input/output words (dependent on configuration)		
Technical data						
Measuring range	0...+9.995 V			-10...+9.995 V		
Resolution	12 Bit			12 Bit		
Scanning frequency	< 2 ms			< 2 ms		
Offset error	typ. 0.5 LSB; max. 1 LSB			typ. 0.5 LSB; max. 1 LSB		
Channel crosstalk	-74 dB (f < 100 Hz)			-74 dB (f < 100 Hz)		
Gain error	input: max. 0.2 % FSR; output: max. 0.12 % FSR			typ. 0.08 % FSR; max. 0.2 % FSR		
Noise voltage	typ. 0.5 LSB; max. 2 LSB			typ. 0.5 LSB; max. 2 LSB		
Offset error	input: +3 LSB/kOhm (Uinput = 0 V); output: max. 10 mV			+3 LSB/kOhm (Uinput = 0 V)		
Electrical isolation	75 V (AGND/Shield)			75 V (AGND/Shield)		
Common-mode range	+12.8 V DC			-12.8 V/+12.8 V DC		
Input resistance	1 MOhm			1 MOhm		
Input current/Output current	typ. 15 μ A/10 mA			typ. 15 μ A		
Short circuit current/short circuit duration	20 mA/100 % ED			20 mA/100 % ED		
Ripple	5 mV			5 mV		
Voltage range for two-way detection of wire breakage	9.9 V (floating source)			-10 V/9.9 V (floating source)		
Common-mode rejection	87 dB (f = DC); 70 dB (f = 50 Hz); 60 dB (f = 1 kHz)			87 dB (f = DC); 70 dB (f = 50 Hz); 60 dB (f = 1 kHz)		
Common-mode input resistance	500 kOhm (inputs short-circuited to AGND)			500 kOhm (inputs short-circuited to AGND)		
Capacitive common-mode input resistance	4.4 nF (inputs short-circuited to AGND)			4.4 nF (inputs short-circuited to AGND)		
Dynamic common-mode input resistance	1.1 kOhm (f > 100 kHz)			1.1 kOhm (f > 100 kHz)		
Insulation voltage	350 V AC, 50 Hz (system/supply)			350 V AC, 50 Hz (system/supply)		
Creepage distances and clearances	DIN EN 61131-2; DIN EN 50178			DIN EN 61131-2; DIN EN 50178		
Electrostatic discharge	EN 61000-4-2; 8 kV air; 4 kV contact			EN 61000-4-2; 8 kV air; 4 kV contact		
Electrostatic fields	ENV 50140; 10 V/m; 30...1000 MHz			ENV 50140; 10 V/m; 30...1000 MHz		
Interference immunity/emitted interference	EN 61000-6-2/EN 55011; limit value A; group 1			EN 61000-6-2/EN 55011; limit value A; group 1		
Burst	according to EN 61000-4-4			according to EN 61000-4-4		
Connection technology	Spring clamp terminal			Spring clamp terminal		
Wire range: fine-stranded/solid	0.14 mm ² – 1.5 mm ² /0.5 mm ² – 2.5 mm ²			0.14 mm ² – 1.5 mm ² /0.5 mm ² – 2.5 mm ²		
Ambient temperature	0 °C...+55 °C			0 °C...+55 °C		
Storage temperature	-25 °C...+75 °C			-25 °C...+75 °C		
Accessories						
Snap-on distribution board 3 and 4 wire operation		83.039.0000.0	1		83.039.0000.0	1
Adhesive labels, A4 sheet		05.591.3089.0	10		05.591.3089.0	10
2 pole jumper for parallel connection of outputs		Z7.258.1225.0	10		Z7.258.1225.0	10
8 digit marking tag, blank		04.242.1553.0	500		04.242.1553.0	500
8 digit marking tag, with inscription (on request)						
End clamp for DIN rail		Z5.522.8553.0	100		Z5.522.8553.0	100

Remote I/O Analog I/O modules

ricos

- For default signals 0...20 mA or 4...20 mA
- For 2, 3 and 4 wire connection
- Electronics can be replaced without disconnection of the wiring



ricos 4AI/0–20 mA
4 inputs 0 to 20 mA
Approvals:



ricos 4AI/4–20 mA
4 inputs 0 to 20 mA
Approvals:

Dimensions (mm): W x H x D
69 x 92 x 51

Description	Type	Part No.	Std. Pack	Type	Part No.	Std. Pack
Display of operating modes: 24 V – power supply connected: yellow LED RUN – internal data transmission is running: yellow LED Channel LED – switching state: green LED Channel LED – channel cursor: yellow LED	ricos 4AI/0–20 mA	83.035.4010.1	1	ricos 4AI/4–20 mA	83.035.4011.1	1
Module data						
Number of inputs	4			4		
Number of outputs	0			0		
Operating voltage	24 V DC, ±20 %, max. 5 % residual ripple			24 V DC, ±20 %, max. 5 % residual ripple		
Power consumption	< 2.5 W			< 2.5 W		
Configuration	PC, PLC, diagnostics code 9 bus coupler			PC, PLC, diagnostics code 9 bus coupler		
Memory space required by the control	1 to 4 input words (dependent on configuration)			1 to 4 input words (dependent on configuration)		
Technical data						
Measuring range	0...+19.995 mA			4...+19.995 mA		
Resolution	12 Bit			12 Bit		
Scanning frequency	2 ms			2 ms		
Offset error	typ. 0.5 LSB; max. 1 LSB			typ. 0.5 LSB; max. 1 LSB		
Channel crosstalk	–74 dB (f < 100 Hz)			–74 dB (f < 100 Hz)		
Gain error	max. 0.45 % FSR			max. 0.45 % FSR		
Noise voltage	typ. 0.5 LSB; max. 2 LSB			typ. 0.5 LSB; max. 2 LSB		
Drift Rate	–			–		
Electrical isolation	75 V (AGND/Shield)			75 V (AGND/Shield)		
Load	max. 100.1 Ohm			max. 100.1 Ohm		
Continuous input current	40 mA at 100 % ED			40 mA at 100 % ED		
Continuous output voltage	4 V at 100 % ED			4 V at 100 % ED		
Short circuit current/short circuit duration	–			–		
Ripple	–			–		
Dynamic common-mode input resistance	1.1 kOhm (f > 100 kHz)			1.1 kOhm (f > 100 kHz)		
Insulation voltage	350 V AC, 50 Hz (system/supply)			350 V AC, 50 Hz (system/supply)		
Creepage distances and clearances	DIN EN 61131-2; DIN EN 50178			DIN EN 61131-2; DIN EN 50178		
Electrostatic discharge	EN 61000-4-2; 8 kV air; 4 kV contact			EN 61000-4-2; 8 kV air; 4 kV contact		
Electrostatic fields	ENV 50140; 10 V/m; 30...1000 MHz			ENV 50140; 10 V/m; 30...1000 MHz		
Interference immunity/emitted interference	EN 61000-6-2/EN 55011; limit value A; group 1			EN 61000-6-2/EN 55011; limit value A; group 1		
Burst	according to EN 61000-4-4			according to EN 61000-4-4		
Connection technology	Spring clamp terminal			Spring clamp terminal		
Wire range: fine-stranded/solid	0.14 mm ² – 1.5 mm ² /0.5 mm ² – 2.5 mm ²			0.14 mm ² – 1.5 mm ² /0.5 mm ² – 2.5 mm ²		
Ambient temperature	0 °C...+55 °C			0 °C...+55 °C		
Storage temperature	–25 °C...+75 °C			–25 °C...+75 °C		
Accessories						
Snap-on distribution board 3 and 4 wire operation		83.039.0000.0	1		83.039.0000.0	1
Adhesive labels, A4 sheet		05.591.3089.0	10		05.591.3089.0	10
2 pole jumper for parallel connection of outputs		Z7.258.1225.0	10		Z7.258.1225.0	10
8 digit marking tag, blank		04.242.1553.0	500		04.242.1553.0	500
8 digit marking tag, with inscription (on request)						
End clamp for DIN rail		Z5.522.8553.0	100		Z5.522.8553.0	100

Remote I/O Analog I/O modules

ricos

- For default signal 0...20 mA / 4...20 mA
- For 2, 3 and 4 wire connection
- Electronics can be replaced without disconnecting wiring



ricos 4AI4AO/0–20 mA
4 inputs and 4 outputs 0 to 20 mA
Approvals: cULus



ricos 4AI4AO/4–20 mA
4 inputs and 4 outputs 0 to 20 mA
Approvals: cULus

Dimensions (mm): W x H x D
69 x 92 x 51

Description	Type	Part No.	Std. Pack	Type	Part No.	Std. Pack
	ricos 4AI4AO/0–20 mA	83.035.4110.1	1	ricos 4AI4AO/4–20 mA	83.035.4111.1	1
Display of operating modes:						
24 V – power supply connected: yellow LED						
RUN – internal data transmission is running: yellow LED						
Channel LED – switching state: green LED						
Channel LED – channel cursor: yellow LED						
Module data						
Number of inputs	4			4		
Number of outputs	4			4		
Operating voltage	24 V DC, ±20 %, max. 5 % residual ripple			24 V DC, ±20 %, max. 5 % residual ripple		
Power consumption	< 2.5 W			< 2.5 W		
Configuration	PC, PLC, diagnostics code 9 bus coupler			PC, PLC, diagnostics code 9 bus coupler		
Memory space required by the control	1 to 4 input/output words (dependent on configuration)			1 to 4 input/output words (dependent on configuration)		
Technical data						
Measuring range	0...+19.995 mA			4...+19.995 mA		
Resolution	12 Bit			12 Bit		
Scanning frequency	2 ms			2 ms		
Offset error	input: max. 1 LSB; output: max. 4 µA			input: max. 1 LSB; output: max. 4 µA		
Channel crosstalk	–74 dB (f < 100 Hz)			–74 dB (f < 100 Hz)		
Gain error	input: max. 0.45 % FSR; output: max. 0.5 % FSR			input: max. 0.45 % FSR; output: max. 0.5 % FSR		
Noise voltage	typ. 0.5 LSB; max. 2 LSB			typ. 0.5 LSB; max. 2 LSB		
Drift Rate	4 µA/ms			4 µA/ms		
Electrical isolation	75 V (AGND/Shield)			75 V (AGND/Shield)		
Load	input: max. 100.1 Ohm; output: 500 Ohm			input: max. 100.1 Ohm; output: 500 Ohm		
Continuous input current	40 mA at 100 % ED			40 mA at 100 % ED		
Continuous output voltage	4 V at 100 % ED			4 V at 100 % ED		
Short circuit current/short circuit duration	20 mA; 100 % ED			20 mA; 100 % ED		
Ripple	10 µA			10 µA		
Dynamic common-mode input resistance	1.1 kOhm (f > 100 kHz)			1.1 kOhm (f > 100 kHz)		
Insulation voltage	350 V AC, 50 Hz (system/supply)			350 V AC, 50 Hz (system/supply)		
Creepage distances and clearances	DIN EN 61131-2; DIN EN 50178			DIN EN 61131-2; DIN EN 50178		
Electrostatic discharge	EN 61000-4-2; 8 kV air; 4 kV contact			EN 61000-4-2; 8 kV air; 4 kV contact		
Electrostatic fields	ENV 50140; 10 V/m; 30...1000 MHz			ENV 50140; 10 V/m; 30...1000 MHz		
Interference immunity/emitted interference	EN 61000-6-2/EN 55011; limit value A; group 1			EN 61000-6-2/EN 55011; limit value A; group 1		
Burst	according to EN 61000-4-4			according to EN 61000-4-4		
Connection technology	Spring clamp terminal			Spring clamp terminal		
Wire range: fine-stranded/solid	0.14 mm ² – 1.5 mm ² /0.5 mm ² – 2.5 mm ²			0.14 mm ² – 1.5 mm ² /0.5 mm ² – 2.5 mm ²		
Ambient temperature	0 °C...+55 °C			0 °C...+55 °C		
Storage temperature	–25 °C...+75 °C			–25 °C...+75 °C		
Accessories						
Snap-on distribution board 3 and 4 wire operation		83.039.0000.0	1		83.039.0000.0	1
Adhesive labels, A4 sheet		05.591.3089.0	10		05.591.3089.0	10
2 pole jumper for parallel connection of outputs		Z7.258.1225.0	10		Z7.258.1225.0	10
8 digit marking tag, blank		04.242.1553.0	500		04.242.1553.0	500
8 digit marking tag, with inscription (on request)						
End clamp for DIN rail		Z5.522.8553.0	100		Z5.522.8553.0	100

Remote I/O Circuit diagrams

ricos

Circuit diagrams for digital modules

- ricos 4AI/0...10 V**
- ricos 4 AI/±10 V**
- ricos 4AI/0...20 mA**
- ricos 4AI/4...20 mA**

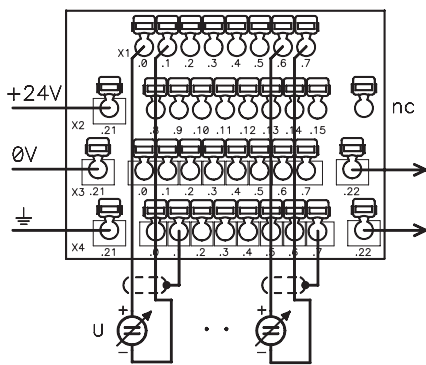

- ricos 4AI4AO/0...10 V**
- ricos 4AI4AO/±10 V**
- ricos 4AI4AO/0...20 mA**
- ricos 4AI4AO/4...20 mA**

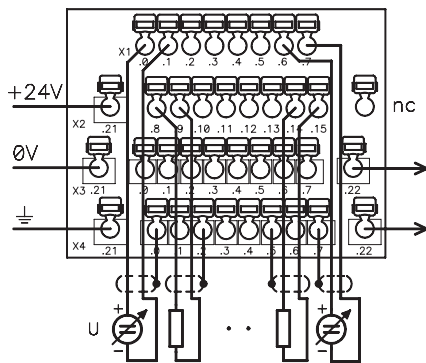

Remote I/O

Fieldbus couplers including binary inputs and outputs

ricos

- Compact modules can be configured as input or output for 2, 3 and 4 wire connection
- Electronics can be replaced without disconnecting wiring



Dimensions (mm): W x H x D
69 x 92 x 51

*Approvals in preparation

ricos COM-DP
Compact modules for Profibus DP
Approvals: us, Profibus certification

ricos COM-S
Compact modules for Interbus
Approvals: us

Description	Type	Part No.	Std. Pack	Type	Part No.	Std. Pack
8 binary inputs and outputs	ricos COM-DP 8I/O	83.030.1100.1	1	ricos COM-S 8I/O	83.031.1100.1	1
16 binary inputs	ricos COM-DP 16I	83.030.1000.1	1	ricos COM-S 16I	83.031.1000.1	1
16 binary outputs	ricos COM-DP 16O	83.030.1200.1	1	ricos COM-S 16O	83.031.1200.1	1
8 I and 8 I/O, binary (parameterizable)*	ricos COM-DP 8I 8I/O	83.030.1300.1	1	ricos COM-S 8I 8I/O	83.031.1300.1	1
Display of operating modes:						
24 V – power supply connected: yellow LED						
RUN – internal data transmission is running: yellow LED						
Channel LED – switching state: green LED						
Channel LED – switching state: yellow LED						
System data						
Maximum number of nodes	99			256		
Transmission medium	Shielded copper cable 2 x 0.25 mm ² /AWG 23			Shielded copper cable 5 x 0.25 mm ² /AWG 23		
Maximum system expansion	100 m – 1200 m (dependent on baud rate/cable)			400 m (Remote bus)		
Baud rate	9.6 kBaud...12 MBaud			500 kBaud		
Internal bus refresh rate	2 ms			2 ms		
Bus connection	1 x D-SUB 9, female connector with shield			6 and 8 pole screw terminal, pluggable		
Input data						
Switching level "0" (EN 61131-2)	-30 V...+5 V DC			-30 V...+5 V DC		
Switching level "1" (EN 61131-2)	+15 V...+30 V DC			+15 V...+30 V DC		
Input current/channel (at 24 V DC)	4.5 mA, 6.5 mA (combined I/O)			4.5 mA/6.5 mA (combi I/O)		
Status display	green LED			green LED		
Output data						
Output voltage	Operating voltage -0.5 V DC			Operating voltage -0.5 V DC		
Output current per channel	1 A DC			1 A DC		
Maximum total current per module	4 A DC			4 A DC		
Concurrence	100 % at max. 500 mA per channel			100 % at max. 500 mA per channel		
Load types	resistive, inductive			resistive, inductive		
Status display	green LED			green LED		
Output behavior	Resistant to overload and short circuits			Resistant to overload and short circuits		
General						
Signal delay per I/O channel	< 100 µs			< 100 µs		
Maximum voltage of power contact	30 V DC			30 V DC		
Maximum current of power contact	8 A DC			8 A DC		
Insulation voltage	350 V AC, 50 Hz (system/supply)			350 V AC, 50 Hz (system/supply)		
Creepage distances and clearances	DIN EN 61131-2; DIN EN 50178			DIN EN 61131-2; DIN EN 50178		
Electrostatic discharge	EN 61000-4-2; 8 kV air; 4 kV contact			EN 61000-4-2; 8 kV air; 4 kV contact		
Electrostatic fields	ENV 50140; 10 V/m; 30...1000 MHz			ENV 50140; 10 V/m; 30...1000 MHz		
Interference immunity/emitted interference	EN 61000-6-2/EN 55011; limit value A; group 1			EN 61000-6-2/EN 55011; limit value A; group 1		
Burst	according to EN 61000-4-4			according to EN 61000-4-4		
Connection technology	Spring clamp terminal			Spring clamp terminal		
Wire range: fine-stranded/solid	0.14 mm ² – 1.5 mm ² /0.5 mm ² – 2.5 mm ²			0.14 mm ² – 1.5 mm ² /0.5 mm ² – 2.5 mm ²		
Ambient temperature	0 °C...+55 °C			0 °C...+55 °C		
Storage temperature	-25 °C...+75 °C			-25 °C...+75 °C		
Accessories						
Snap-on distribution board 3 and 4 wire operation		83.039.0000.0	1		83.039.0000.0	1
Adhesive labels, A4 sheet		05.591.3089.0	10		05.591.3089.0	10
2 pole jumper for parallel connection of outputs		Z7.258.1225.0	10		Z7.258.1225.0	10
8 digit marking tag, blank		04.242.1553.0	500		04.242.1553.0	500
8 digit marking tag, with inscription (on request)						
End clamp for DIN rail		Z5.522.8553.0	100		Z5.522.8553.0	100
GSD file and Word document for labels		05.591.3255.0	1		05.591.3255.0	1

Remote I/O

Fieldbus couplers including binary inputs and outputs

ricos

- Compact module can be configured as input or output for 2, 3 and 4 wire connection
- Electronics can be replaced without disconnecting wiring



ricos COM-DN
DeviceNet compact module
Approvals:



ricos COM-CO
CANopen compact module
Approvals:

Dimensions (mm): W x H x D
69 x 92 x 51

*Approvals in preparation

Description	Type	Part No.	Std. Pack	Type	Part No.	Std. Pack
8 binary inputs and outputs (parameterizable)	ricos COM-DN 8I/O	83.032.1100.1	1	ricos COM-CO 8I/O	83.033.1100.1	1
16 binary inputs	ricos COM-DN 16I	83.032.1000.1	1	ricos COM-CO 16I	83.033.1000.1	1
16 binary outputs	ricos COM-DN 16O	83.032.1200.1	1	ricos COM-CO 16O	83.033.1200.1	1
8 I and 8 I/O, binary (parameterizable)	ricos COM-DN 8I 8I/O	83.032.1300.1	1	ricos COM-CO 8I 8I/O	83.033.1300.1	1
Display of operating modes:						
24 V – power supply connected: yellow LED						
RUN – internal data transmission is running: yellow LED						
Channel LED – switching state: green LED						
Channel LED – switching state: yellow LED						
System data						
Maximum number of nodes	64 with repeater			64		
Transmission medium	Shielded copper cable trunk line AWG 15, 18 Shielded copper cable drop line AWG 22, 24			Shielded copper cable 3 x 0.25 mm ² /AWG 23		
Maximum system expansion	100 m – 500 m (dependent on baud rate/cable)			100 m – 500 m (dependent on baud rate/cable)		
Baud rate	125/250/500 kBaud (setting via keyboard)			10 kBaud...1 MBaud (setting via keyboard)		
Internal bus refresh rate	2 ms			2 ms		
Bus connection	5 pole connector, screw terminal			5 pole connector, screw terminal		
Input data						
Switching level "0" (EN 61131-2)	–30 V...+5 V DC			–30 V...+5 V DC		
Switching level "1" (EN 61131-2)	+15 V...+30 V DC			+15 V...+30 V DC		
Input current/channel (at 24 V DC)	4.5 mA/6.5 mA (combined I/O)			4.5 mA/6.5 mA (combined I/O)		
Status display	green LED			green LED		
Output data						
Output voltage	Operating voltage –0.5 V DC			Operating voltage –0.5 V DC		
Output current per channel	1 A DC			1 A DC		
Maximum total current per module	4 A DC			4 A DC		
Concurrence	100 % at max. 500 mA per channel			100 % at max. 500 mA per channel		
Load types	resistive, inductive			resistive, inductive		
Status display	green LED			green LED		
Output behavior	Resistant to overload and short circuits			Resistant to overload and short circuits		
General						
Signal delay per I/O channel	< 100 µs			< 100 µs		
Maximum voltage of power contact	30 V DC			30 V DC		
Maximum current of power contact	8 A DC			8 A DC		
Insulation voltage	350 V AC, 50 Hz (system/supply)			350 V AC, 50 Hz (system/supply)		
Creepage distances and clearances	DIN EN 61131-2; DIN EN 50178			DIN EN 61131-2; DIN EN 50178		
Electrostatic discharge	EN 61000-4-2; 8 kV air; 4 kV contact			EN 61000-4-2; 8 kV air; 4 kV contact		
Electrostatic fields	ENV 50140; 10 V/m; 30...1000 MHz			ENV 50140; 10 V/m; 30...1000 MHz		
Interference immunity/emitted interference	EN 61000-6-2/EN 55011; limit value A; group 1			EN 61000-6-2/EN 55011; limit value A; group 1		
Burst	according to EN 61000-4-4			according to EN 61000-4-4		
Connection technology	Spring clamp terminal			Spring clamp terminal		
Wire range: fine-stranded/solid	0.14 mm ² – 1.5 mm ² /0.5 mm ² – 2.5 mm ²			0.14 mm ² – 1.5 mm ² /0.5 mm ² – 2.5 mm ²		
Ambient temperature	0 °C...+55 °C			0 °C...+55 °C		
Storage temperature	–25 °C...+75 °C			–25 °C...+75 °C		
Accessories						
Snap-on distribution board 3 and 4 wire operation		83.039.0000.0	1		83.039.0000.0	1
Adhesive labels, A4 sheet		05.591.3089.0	10		05.591.3089.0	10
2 pole jumper for parallel connection of outputs		Z7.258.1225.0	10		Z7.258.1225.0	10
8 digit marking tag, blank		04.242.1553.0	500		04.242.1553.0	500
8 digit marking tag, with inscription (on request)						
End clamp for DIN rail		Z5.522.8553.0	100		Z5.522.8553.0	100
GSD file and Word template for labels		05.591.3255.0	1		05.591.3255.0	1

Circuit diagrams for compact modules

ricos COM 8I/O

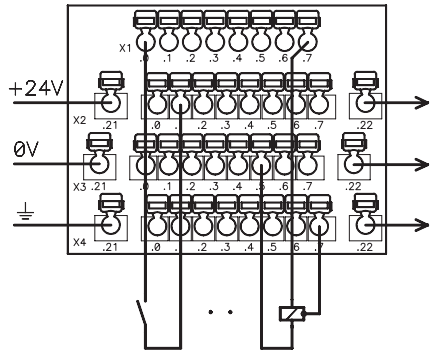

ricos COM 16I

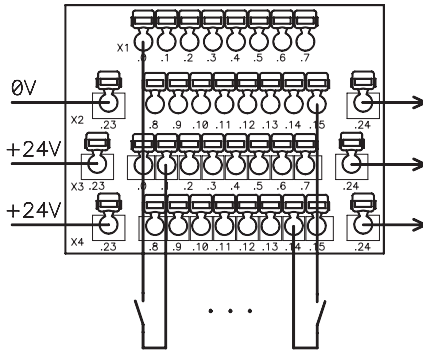

ricos COM-DP

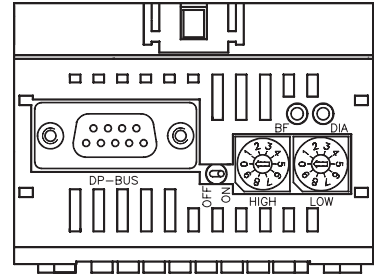

ricos COM 16O

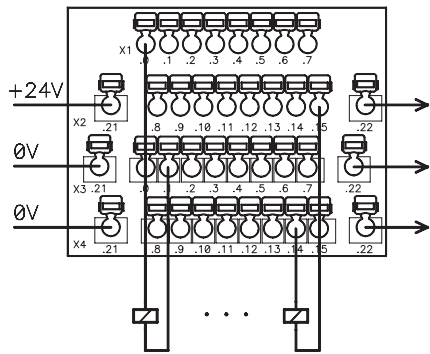

ricos COM 8I 8I/O

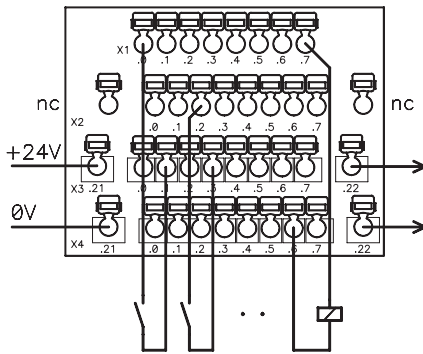

ricos COM-S

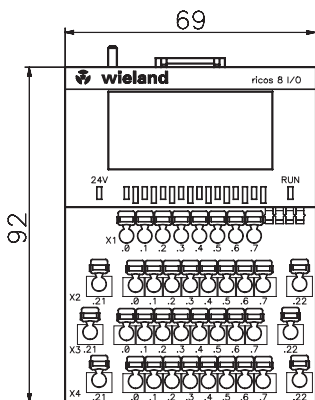
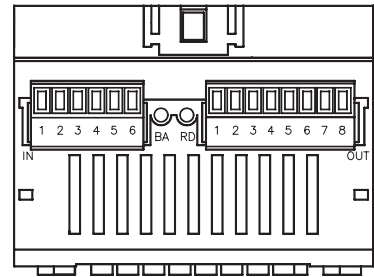

Derating

Total current

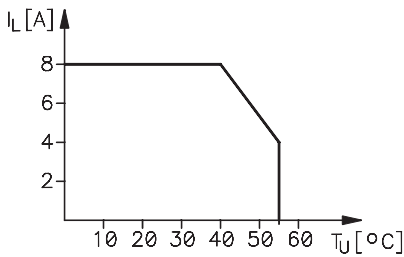

ricos COM CAN DN
ricos COM CANopen

