

Industrial technology

- Solutions for the control cabinet
- DIN rail terminal blocks
 - Screw, spring clamp or IDC connection technology
 - Wire cross sections up to 240 mm²
 - Numerous special functions
 - Software solutions interfacing to CAE systems
 - Safety
 - Safety sensors
 - Safety relays
 - Modular safety systems with fieldbus link
 - PLC and fieldbus components
 - Standard applications in IP20
 - Increased environmental conditions with railroad and ship approvals
 - Interface
 - Coupling relays, semiconductor switches
 - Measuring and monitoring relays
 - Timer and switching relays
 - Analog modules
 - Passive interfaces
 - Power supply units
 - Overvoltage protection

Solutions for field applications

- Remote automation technology
 - Power distribution
 - Fieldbus interfaces and motor starters
- Connectors for industrial applications
 - Square and round connectors
 - Aluminum or plastic housings
 - Degree of protection up to IP68
 - Current-carrying capacity up to 100A
 - Connectors for hazardous areas
 - Modular, application specific technology

PC board terminals and connectors

- Screw or spring clamp connection technology
- Spacings: 3.5mm to 10.16mm
- Reflow or wave soldering process

Building and installation technology

- Building installation systems
 - Main power supply connectors IP20/IP65...IP68
 - Bus connectors
 - Combined connectors
 - Low-voltage connectors
 - Power distribution system with flat cables
 - Distribution systems
 - Bus systems in KNX, LON and radio technology
 - DIN rail terminal blocks for electrical installations
 - Overvoltage protection

fasis



fasis
DIN Rail Terminal Blocks
with Tension
Spring Connection



DIN rail terminal blocks with tension spring connection, type WKFN
fasis

Technical information

- The information regarding cross sectional area and connection types pertains to unprepared wires without ferrules! Ferrules are not necessary for secure connection! Whenever ferrules are used, make sure that the tools specified by the manufacturer are used exclusively.
- The voltage ratings apply to the terminals in their intended application. When different products are mounted adjacent to each other, the proper isolation distances must be adhered to.
- If the ground blocks of the **fasis** product family are not used in block assemblies, but are mounted to the rail as single terminal blocks, end clamps have to be used.
- A detailed description of technical data, the standards requirements, and the application conditions are available under **facts** & DATA.

ATEX regulation

- For the use of DIN rail terminal blocks in Ex areas, the regulations of EN 60079-0 apply; whereas for increased safety Ex e the regulations of EN 60079-7 must be followed. For an approximation of the laws of the EU member states directive 94/9/EG was created, which is generally known as ATEX 100a and which is the basis for harmonization in this field. ATEX stands for "atmosphere explosive" while 100a refers to the corresponding article of the EC contract.
- Directive ATEX 100a applies for protection against dust and gas explosions in all industrial Ex areas and in mining. The testing and certifying institutes named in directive ATEX 100a must follow accreditation procedures which are the same throughout Europe.
- In accordance with EN 60079-0/60079-7 and ATEX 100a, these certifying institutes write out EC certificates for prototype tests. These prototype test certificates for components together with the corresponding quality system certification of the supplier are required to obtain the so-called ATEX approval.
- In combination with the **Ex**-mark, the markings of the Wieland terminal blocks have the following meanings:

Ex	Identification
II	Device group
2	Category
G D	Areas
KEMA	Name of testing institute
ATEX...	Certificate, year of testing, number

Mounting instructions for Ex e applications:

- If feed-through blocks are mounted directly adjacent to other feed-through blocks of a different size, or directly adjacent to ground blocks, the open side of the block group of the same type must be covered by an end plate or partition.
- If adjacent DIN rail terminal blocks are jumpered or if jumpered DIN rail terminal blocks are positioned next to unjumpered DIN rail terminal blocks, a partition plate must be inserted between the individual terminal block groups or at the beginning and end of a laterally or longitudinally connected terminal block (group) in order to meet the specified isolation distances. Notched out and jumpering cross connectors cannot be used in Ex areas.
- If the terminal blocks are combined with other certified series and sizes and when their accessories are used, the required creepage distances and clearances must be adhered to.
- The feed through terminal blocks and protective conductor terminal blocks are suitable for enclosures for use in explosive gas atmospheres or for use in the presence of combustible dust. For explosive gas atmospheres these enclosures must satisfy the requirements of EN 60079-0 and EN 60079-7. For combustible dust these enclosures must satisfy the requirements of EN 61241-0 and EN 61241-1
- The indicated values for the current carrying capability refer to a maximum ambient temperature of 40°C. When the terminal blocks are loaded with the maximum rated current the temperature rise will be max. 40K.

DQS certification for all company sectors

- Quality standard as per DIN ISO 9001 in Development, Production and Assembly
- Continued control of the quality standard by means of regular internal and external quality audits
- Compatible with certificates of other countries:
 - BSI Certificate, Great Britain
 - SQS Certificate, Switzerland
 - Aib-Vincotte Certificate, Belgium
 - ÖQS Certificate, Austria

contacts are green.

Product Range

A Touch of Spring in Installation

0124.0 C 02/07



DIN rail terminal blocks with tension spring connection



Our competence

"We at **Wieland**" don't do things by halves! Therefore we deliver our products in the highest quality possible and with user-friendly functions. Our 90 years of experience in electrical connections, our more than 20 years of experience in the field of spring clamp technology as well as the quality certifications according to ISO 90001:2000 and ISO 14001 guarantee this.

With products from **Wieland** you've got it all! Whether in ships, on cranes, in trains, or simply in control cabinets or systems, various areas of application stand for a unique know-how.

You as our customer determine our future

DIN rail terminal blocks can be found wherever power is generated, supplied, routed and distributed. Since their invention in the thirties of the last century, their basic design has not changed much. However, the entire surroundings in which terminal blocks are used have undergone a radical change – with the corresponding effects on design and performance capabilities of the connection systems.

We want satisfied customers who enter into long-term relations with us.

Squaring the circle for your benefit

DIN rail terminal blocks have to be marked visibly and be clearly assignable; it has to be possible to connect and jumper them flexibly and universally; finally they must enable testing under complete wiring and without having to disconnect the wires.

We have achieved this goal and have implemented these benefits for our customers with our **fasis** WKFN product series.

Your application is our challenge

Flexibility in connection technology, economic efficiency in stocking and reliability in the application – these are the benefits which **fasis** offers to our users.

If you require explosion or fire protection, vibration or shock resistance or international approvals for worldwide use then **fasis** provides the terminal blocks required for your application.

Individual service for your success

Connection technology is not our priority, as we master it anyway and our customers know it. We put our focus on the added value of our systems.

A user-friendly configuration software supports the wiring tasks while a marking software supports the marking activities. And for those who want to simplify their work in the control cabinet, we pre-assemble completely fitted terminal block assemblies – even with cables connected, if required. Individual components may be delivered within 24 hours under Wieland service **Quick 24**.





































fasis



Catalog section

DIN Rail Terminal Blocks
for Junction Boxes

Part no. 0117.0

 WK 2,5/35	 WK 2,5 D1/2/35	 WK 4/35	 WK 4 D1/2/35	 WK 16/35 PV/WK
 WK 6/35	 WK 10/35	 WK 16/1/35	 WK 16/35	 WAK 16/2, WAK 35/2
 WK 4 NT/35	 WK 10 NT/35	 WK 16/1 NT/35		
 WK 2,5 SL/35	 WK 2,5 D1/2/SL/35	 WK 4 SL/35	 WK 4 D1/2/SL/35	
 WK 6 SL/35	 WK 10 SL/35	 WK 16/1 SL/35	 WK 16 SL/35	
 WKIF 2,5 D	 WKIF 2,5 D-D WKIF 2,5 N-D	 WKIF 2,5 D-D-SL WKIF 2,5 N-D-SL	 WKIF 2,5 NT-D-SL	 WKIF 2,5 NTM-D-SL
 WKIS 2,5 D	 WKIS 2,5 D-D WKIS 2,5 N-D	 WKIS 2,5 D-D-SL WKIS 2,5 N-D-SL	 WKIS 2,5 NT-D-SL	 WKIS 2,5 NTM-D-SL
 Cross connector	 Notching tool	 PS WK C/F	 Warning symbol/LEL	 Screwdriver

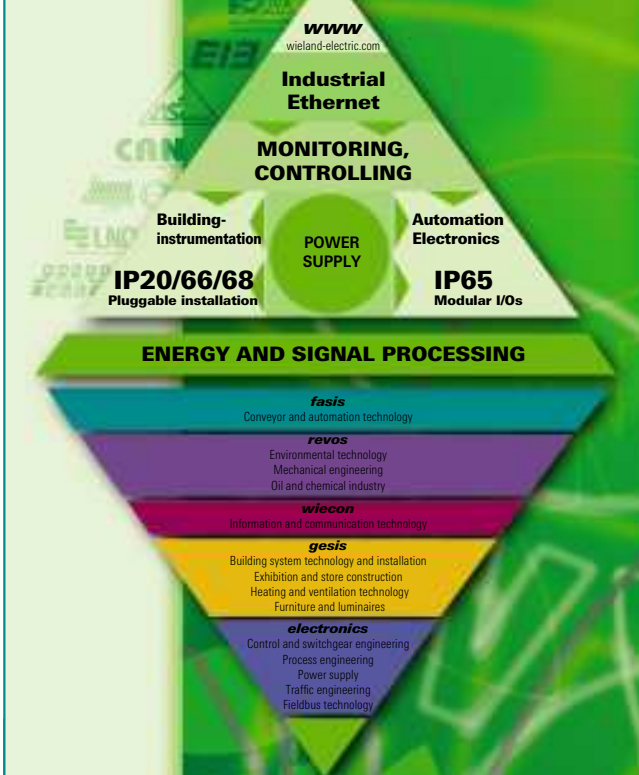

Since its invention, the tension spring connection technology has been established in the market as an industrial standard along with screw and crimp connection technology. Technical advantages such as easy handling and vibration-proof contacting as well as economic advantages such as time savings and cost reduction in wiring are responsible for this success.

Competence in spring connection technology means safety and reliability for the future.

You can find such a wide product range in tension spring connection technology only at **Wieland Electric** DIN rail terminal blocks, PC board connectors, electronic components, industrial multipole connectors or the pluggable electrical installation system.



■ **revos** – industrial multipole connectors

Our industrial multipole connectors provide reliable protection against dirt, dust and water, vapors, gases and electromagnetic influences.

Multipole adapters and contact inserts with tension spring technology are available in all standard sizes and are ideal for rough environments.

The dynamic terminal connection inside the connector ensures a durable and safe contact.



■ **Electronics** – electronic components

The quality of our electronic products is the basis for the high degree of reliability.

It is an important advantage of digital bus technology that signal processing is possible in field devices, and that intelligence can therefore be distributed in the field.

For this reason, **ricos** modules with channels that can be used optionally as input or as output can be as interesting as the clear wiring.

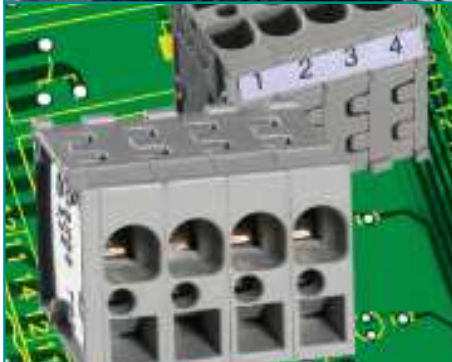

■ **wiecon** – PC board connectors

wiecon is a fixed component of innumerable innovative applications.

Clear identification, simple wire connection and an intelligent test function of the reliable tension spring connection stand for easy handling.

The service-friendly usability of **wiecon** is guaranteed!



































■ **gesis**® – pluggable electrical installation







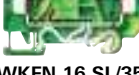
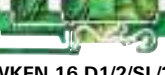













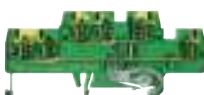

















gesis – one name, one system!

The unique variety of components offers solutions for any kind of electrical installation. Consumer devices such as luminaires, sunblind drives, outlets or requirements for IP66/IP68 protection degree such as in automatic car wash systems, ships, airports and soccer stadiums can easily be incorporated in the installation system.

DIN rail terminal blocks with spring clamp connection































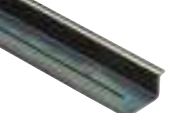



fasis *SIS*

Page 16/17	 WKF 1,5/35	 WKF 1,5 D1/2/35	 WKF 1,5 D2/2/35		
Page 18/19	 WKF 1,5 SL/35	 WKF 1,5 D1/2/SL/35	 WKF 1,5 D2/2/SL/35		
Page 20/21	 WKFN 2,5 /35	 WKFN 2,5 D1/2/35	 WKFN 2,5 D2/2/35		 WKF 16 /35 PV/WKFN
Page 22/23	 WKFN 2,5 SL/35	 WKFN 2,5 D1/2/SL/35	 WKFN 2,5 D2/2/SL/35		
Page 24/25	 WKFN 4 /35	 WKFN 4 D1/2/35	 WKFN 4 D2/2/35		 WKF 16 /35 PV/WKFN
Page 26/27	 WKFN 4 SL/35	 WKFN 4 D1/2/SL/35	 WKFN 4 D2/2/SL/35		
Page 28/29	 WKFN 6/35	 WKFN 6 D1/2/35	 WKFN 6 SL/35	 WKFN 6 D1/2/SL/35	
Page 30/31	 WKFN 10/35	 WKFN 10 D1/2/35	 WKFN 10 SL/35	 WKFN 10 D1/2/SL/35	
Page 32/33	 WKFN 16/35	 WKFN 16 D1/2/35	 WKFN 16 SL/35	 WKFN 16 D1/2/SL/35	
Page 34/35	 WKF 35/35		 WKF 35 SL/35		

Page 36/37	 WK F 1,5 E2/35	 WK F 1,5 E2/VB/35	 WK F 1,5 E2/SL/35		
Page 38/39	 WKFN 2,5 E/35 WKFN 2,5 E/N/D/35	 WKFN 2,5 E/VB/35	 WKFN 2,5 E/D/SL/35 WKFN 2,5 E/N/SL/35	 WKFN 2,5 E/SL/35	
Page 40/41	 WKFN 2,5 E1/2/35 WKFN 2,5 E1/2/N/D/35	 WKFN 2,5 E1/2/VB/35	 WKFN 2,5 E1/2/D/SL/35 WKFN 2,5 E1/2/N/SL/35	 WKFN 2,5 E1/2/SL/35	
Page 42/43	 WKFN 2,5 E3/35	 WKFN 2,5 E3/VB/35	 WKFN 2,5 E3/D/D/SL/35 WKFN 2,5 E3/N/D/SL/35	 WKFN 2,5 E3/SL/35	
Page 44/45	 WKFN 4 E/35 WKFN 4 E/N/D/35	 WKFN 4 E/VB/35	 WKFN 4 E/D/SL/35 WKFN 4 E/N/SL/35	 WKFN 4 E/SL/35	
Page 46/47	 WKFN 2,5 E...G	 WKFN 2,5 E...G		 WKFN 4 E...G	 WKFN 4 E...G
Page 48/49	 WKFN 2,5 TKM/35	 WKFN 2,5 TKM 1/2/35	 WKFN 2,5 TKM 2/2/35		 WKFN 16/35 PV/WKFN
Page 50/51	 WKFN 2,5 TKM E1/35	 WKFN 2,5 TKM E2/35			
Page 52/53	 WKFN 4 TKG with THSi 5 x 20	 WKFN 4 TKG with THSi 6,3 x 32			 WKFN 16/35 PV/WKFN
Page 54/55	 WKFN 4 TKG with SiST	 WKFN 4 TKG with DiST			 WKFN 16/35 PV/WKFN
Page 58/59	 WK F 1,5 KOI 3L WK F 1,5 KOI 3L-PGE	 WK F 1,5 KOI 3L/SL WK F 1,5 KOI 3L/SL-PGE	 WK F 1,5 KOE WK F 1,5 KOE-PGN		 VM WK F...

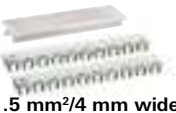
DIN rail terminal blocks with spring clamp connection

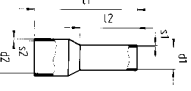
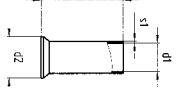
fasis *SIS*

Page 62/63	 WKF 2,5 D2/8113/35	 WKF 2,5 D2/8113/SL/35	 WKF 1,5 E/8113/35	 WKF 1,5 E/35	 8113 BFK
Page 64/65			 WKF 4 3D/SL		
Page 66/67			 WKMF 2,5 /15	 WKMF 2,5 SL/15	
Page 68/69	 WKF 2,5 M/F	 WKF 2,5 MD/F		 WKF 2,5 M/R	 WKF 2,5 MD/R
Page 70/71	 WKF 2,5 M/15	 WKF 2,5 MD/15		 WKF 2,5 M/35	 WKF 2,5 MD/35
Page 72/73	 Cross connectors	 Notching tool	 PS WRC/F	 Warning symbol/LEL	 Screwdriver
Page 74/75	 TS 35x7,5	 TS 35x15	 TS 35x15	 9708/2 S35	 WEF 1/35
Page 76/77	 wieplan	 marcom	 wiemarc	 wieplot 500	 Accessories
Page 78/79	 Marking accessories	 Marking tags	 1.5 mm²/4 mm wide 2.5 mm²/5 mm wide	 4 mm²/6 mm wide	 10 mm²/10 mm wide 16 mm²/12 mm wide 35 mm²/16 mm wide
Page 80/81	 Ferrules	 Ferrules		 Stripping tool 0.08-10 mm²	 Pressing tools

fasis

DIN rail terminal blocks with tension spring connection

fasis

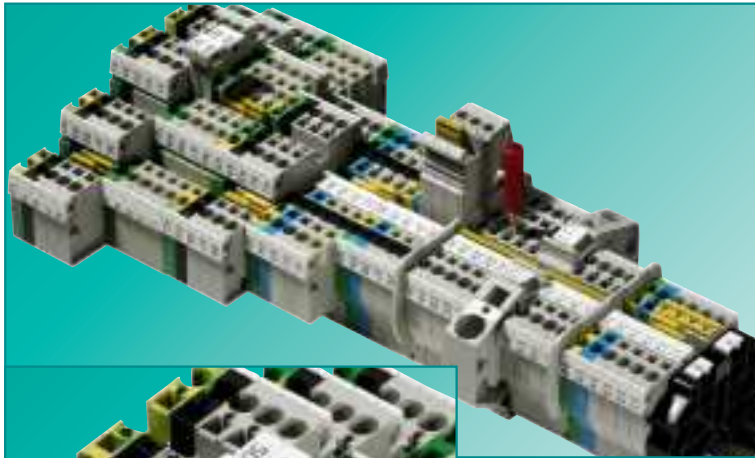

With its **fasis** WKFN series Wieland Electric offers you a complete range of DIN rail terminal blocks with tension spring technology.

The portfolio comprises feed-through and ground blocks with 2, 3 or 4 termination points, two-tier and three-tier blocks, single-tier and two-tier knife-edge disconnect blocks as well as fuse blocks. There are also function blocks with application-specific diode circuits available.

fasis WKFN has been designed for use in machine and system engineering as well as for hazardous areas.

Technical information as per EN 60947-7:

Rated cross section:	1.5–35 mm ²
Rated current:	17.5 A–125 A
Rated voltage:	800/500 V
Wire range:	0.08–35 mm ²

mark

Clearly mark all clamping points

Benefits:

- Marking tags easily readable even with the wires connected.
- Clear assignment of wire to termination point for easy wiring
- Simplified troubleshooting for maintenance operations
- Individual marking with the **wiemarc** marking system

clamp

Flexible and universal connection

Benefits:

- Clamping body as per gauge plug EN 60947-7
- Connection of solid, fine-stranded and stranded wires up to a conductor size larger than the rated cross section for example WKFN 2,5: 0.13 to 4 mm²
- Connection of fine-stranded wires with ferrules and insulated sleeve up to the rated cross section for example WKFN 2,5: 0.5 to 2.5 mm²

jump

Jumpering the terminal blocks on two channels

Benefits:

- Flexible potential distribution through staggered and chained arrangement of the cross connectors.
- Cost reduction in stockkeeping due to standardized variations (preferred number of poles)
- Potential distribution with supply blocks up to 76 A and standard connectors on feed-through terminal blocks.

test

Measuring voltage through integrated testing facility

Benefits:

- Testing when fully wired (including cross connector)
- Testing directly at the current-carrying bar
- Function test with modular test adapter through test point in the jumpering channel

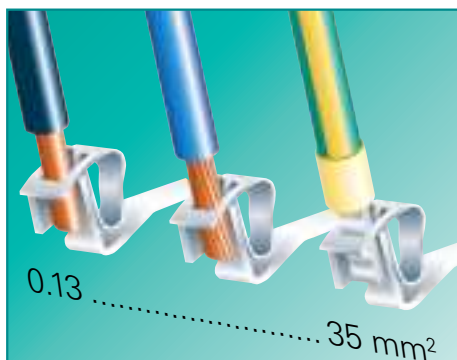

Tension spring connection technology

Durable electrical connection

Benefits:

- The tension spring system provides a dynamic clamping connection. Load-controlled and thermal cold flow properties of the connected wires are balanced.
- Maintenance-free and gas-tight electrical connection as specified by the approvals.
- Isolation of electrical and mechanical functions



Operating tool

Operated with a screwdriver

Benefits:

- Operation of the termination point does **not require any special tools.**
- For an optimal operation of our DIN rail terminal blocks with tension spring connection we recommend cylindrical screwdrivers with wedge-shaped blades according to DIN 5264 B in the size of the terminal blocks' rated cross sections.
- Also see the accessories for DIN rail terminal blocks on page 73!



Wire entry guides

Safe connecting of "small cross sections"

Benefits:

- Ensures the connection of solid and fine-stranded wires smaller than 1 mm².
- Wire entry guides prevent the wires from being inserted too deeply (smaller than 1 mm²) and enable professional contacting.
- Also see the accessories for DIN rail terminal blocks on page 73!



Cover with warning symbol

Marking live potentials

Benefits:

- Cover with warning symbol snapped onto the blocks indicates (high) voltage even when the main switch is disconnected (VDE 0113).
- The cover can only be removed with a tool which ensures safety.
- Also see the accessories for DIN rail terminal blocks on page 73!



Materials

Selection of high-quality materials

Benefits

- Special alloys enable low feed-through resistance and provide a gas-tight contact area:
 - Clamping spring: stainless CrNi steel
 - Current-carrying bar: tin-plated copper
- Polyamide has excellent electrical, chemical and mechanical characteristics
 - Temperature resistance: up to 120 °C
 - Creepage resistance: CTI 600
 - Flammability class: self-extinguishing, UL 94-V0

DIN rail terminal blocks with tension spring connection

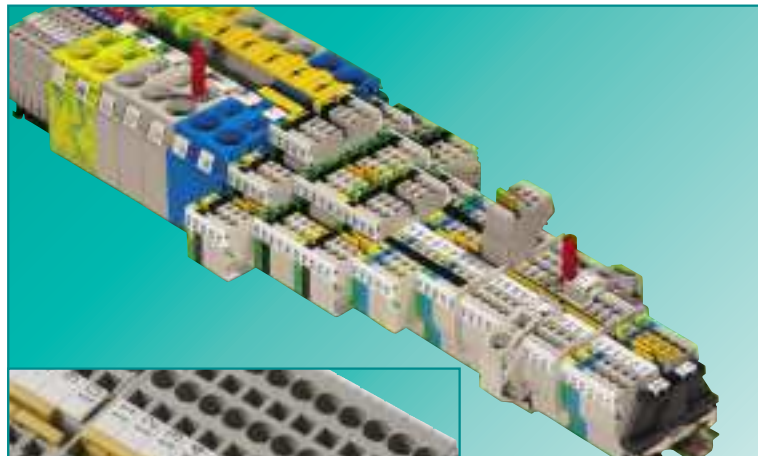

Power and potential distribution

With our **fasis** WKFN DIN rail terminal block system we focus on the application's system and flexibility. This mainly pays off in power and potential distribution.

fasis WKFN is consistently equipped with a two-channel jumpering system. Using standard cross connectors the potential can be distributed from the supply block to other DIN rail terminal blocks of type WKFN 2,5 and WKFN 4. Reducing jumpers for terminal blocks larger than 10 mm² are available as accessories for the distribution of high currents. Later extensions of the distribution system are not a problem and can be implemented quickly and flexibly!

What has proven for the termination point of the DIN rail terminal block is continued for the cross connectors, meaning we isolate the electrical and mechanical functions so that the electrical connections durably function as required and contribute to your system's operational safety.

comfort
jump

Jumpering the terminal blocks on two channels

Benefits:

- Power performance through parallel supply of the electrical power
- Flexible potential distribution through staggered and chained arrangement of the cross connectors
- Cost reduction in stockkeeping due to standardized variations (preferred number of poles)

link
jump

Easy potential interconnection

Benefits:

- Individual interconnection of potentials on the terminal block assembly
- Simply notch through pre-defined cutting edge
- Colored marking of the power circuit with pre-defined marking options

smart
jump

Potenziale einfach verteilen

Benefits:

- Compact and closed design of supply block WKF 16/35 PV/ WKFN for wires up to 16 mm²
- Parallel power distribution on one side or both sides to WKFN standard DIN rail terminal blocks
- Power distribution to WKFN 4 or WKFN 2,5 with standard cross connectors IVB WKF 4 or 2,5

power
jump

Supply power up to 125 A

Benefits:

- Standard DIN rail terminal blocks WKFN 16 and 35 as supply block up to 50 mm²
- Power distribution through reducing jumpers from WKF 35 to WKFN 16
WKF 35 to WKFN 10
WKFN 16 to WKFN 10

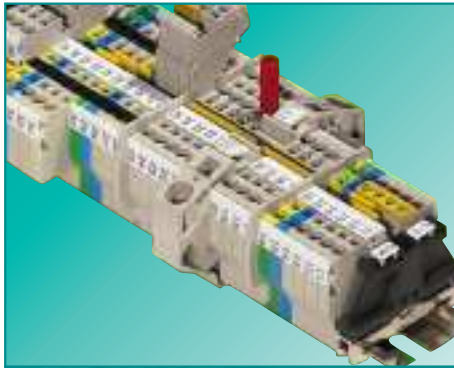

Function

Durably and safe "jumping"

- The DIN rail terminal blocks with tension spring connection of the fasis product series can be "jumped" using insulated cross connectors without screws.
- IP 20 protection against accidental contact is guaranteed even for inserted cross connectors.
- Isolation of the electrical and mechanical functions enables an optimal selection of materials without any compromise.
- The current-carrying bar makes it possible to apply the DIN rail terminal block's rated current to the cross connector.
- The contact spring balances the thermal cold flow properties of the current-carrying bar and thus ensures a durable electrical connection.
- Special alloys ensure a low contact resistance and a gas-tight contact area
 - Current-carrying bar: tin-plated copper
 - Contact spring: stainless CrNi steel

Application

Jumping with a system

- For the **smart jump** potential distribution insulated cross connectors in 2 to 20 pole designs are available.
- „Jumping“ cross connectors are available to interconnect non-adjacent potentials to **link jump**.
- The **power jump** power distribution up to 125A is implemented using reducing cross connectors – see page 35.

Pre-assembly

"Jumping" and distributing potentials

- The jumping potential interconnection is created with notched cross connectors.
- The notched cross connectors
 - can be prepared by the user as required for the application by using the Wieland notching tool, or
 - can be purchased already pre-assembled from Wieland.
- Staggered jumpering with notched cross connectors is only possible with the **fasis** WKFN series.

Flexibility

Individually notched cross connectors

- The notched cross connectors are prepared individually using the AKW/A notching tool.
- In order to easily cut out individual poles the cross connectors provide a pre-defined cutting edge.
- Notched cross connectors will reduce the rated voltage to 400 V.
- All cross connectors with several poles provide a pre-defined marking space which enables colored marking of the current and signal flow.

Configuration software for DIN rail terminal blocks, wieplan



wieplan was developed to provide you with a powerful software tool for the configuration of terminal block assemblies using Wieland DIN rail terminal blocks.

wieplan is available in 4 languages. It is user-friendly and its intuitive user interface guides you step by step through the entire configuration process. After completion you can optionally order your configured terminal block assembly from Wieland for complete pre-assembly.

Thus **wieplan** helps you to save time and money.

Managing projects



Benefits:

- To begin each configuration you automatically start from the basic project management menu.
- You create new projects and are reliably guided through the easy and practice-oriented program logics.
- You always have the choice of either opening an already existing project or of creating a new one.

Configuring terminal block assemblies without errors



Benefits:

- You work with high-quality graphs viewing the terminal blocks from the top; the accessories added are visible at any time.
- You continually use the plausibility check that reminds you of the accessories required such as end plates.
- You are provided with a product catalog with search function; you can add your own order numbers, if required; and you can create libraries for self-defined products.

Entering order data



Benefits:

- You enter your data such as invoice and delivery address in the order data screen only once and can use them for any follow-up orders.
- You may order by e-mail; in this case the terminal block assembly data are zipped automatically.

Terminal block assembly output



Benefits:

- You print out the order, the parts list and the drawing data, and, if required, your own order numbers.
- You create a DXF file and export the current terminal block assembly to a CAD program.
- You export the marking in CSV format including all marking data for further processing in **wiemarc**, for example.
- You can use a bidirectional interface available for your CAE system EPLAN.

Marking system for DIN rail terminal blocks, *wiemarc/wieplot*

fasis

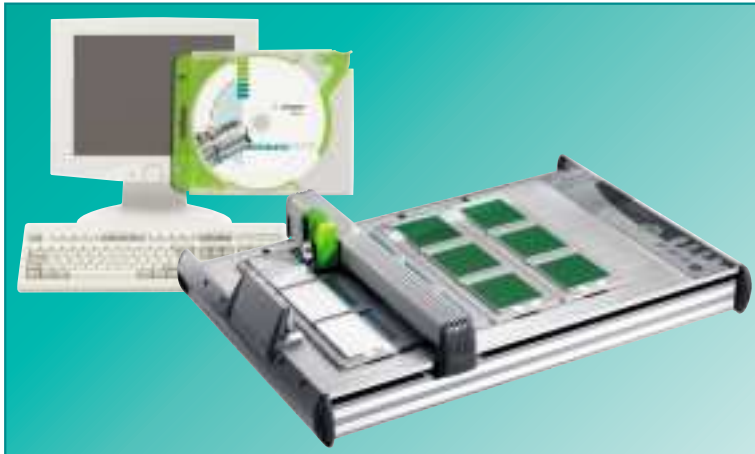

Individual marking of DIN rail terminal blocks means **wiemarc** and **wieplot**. at Wieland Electric. The **wieplot** software was developed to provide you with maximum flexibility in marking your terminal block assemblies. Together with **wieplot** you have a powerful marking system that enables you to work professionally from the individual marking tag to series marking of your terminal block assemblies. You feel confident with the system due to its easy handling and visual representation of your marking, even when you use it for the first time.

But **wieplot** offers even more!

In addition to the marking tags for DIN rail terminal blocks you can also print self-adhesive tags and labels or cable markings. A slight modification can even make your plotter a powerful engraving system.



selos-fasis-taris

Marking with a system

- Individual marking of all terminal blocks for clear wire/termination point assignment
- One single marking system for all designs
- Marking of individual tags; marking strips in the relevant terminal block spacing; or group markings
- Individual planning of terminal block assemblies and markings with **wieplan**



wieplot

Ready for universal use

- Marks all common marking systems available for DIN rail terminal blocks
- Different marking tags can be marked individually in one single work step
- Marking of labels, self-adhesive tags and cables is possible



wiemarc

Easy and quick

- Simple and intuitive user interface
- Direct graphical display of the marking tags including plausibility check
- Customized layouts can be created individually
- Data import from CAD, Excel, text or **wieplan** files



wieplot engraving system

Durable and safe –**wieplot** engraving system

- Easy modification to **wieplot** to make it an engraving system
- Engraving of multi-layer plastic boards
- Clean and dust-proof operation due to integrated vacuum device
- Create individual layouts using **wiemarc**

DIN rail terminal blocks
with tension spring connection

fasis *SIS*

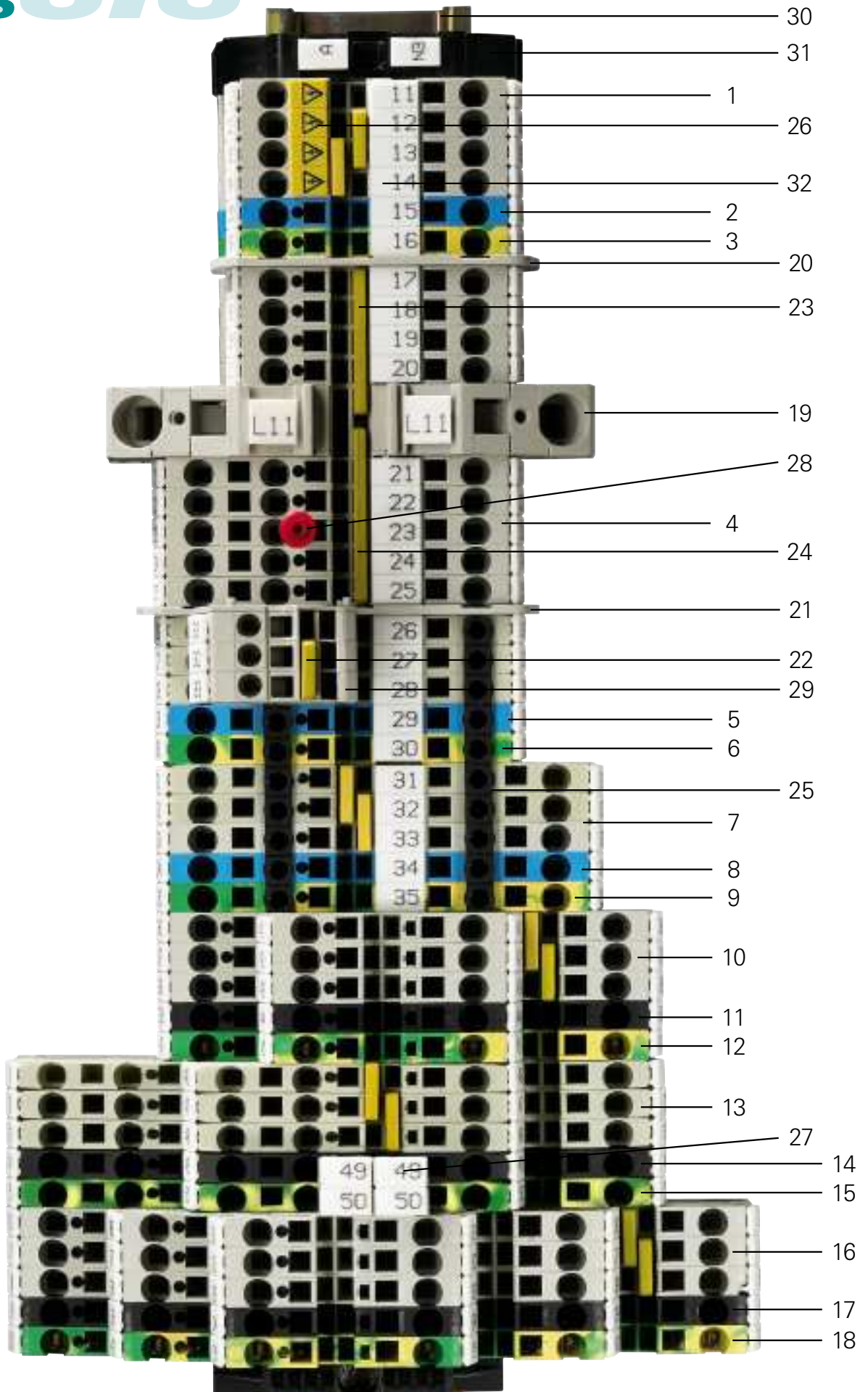

Pos.	Description	Type	Part number
1	Feed-through block	WKFN 2,5/35	56.703.0055.0
2	Feed-through block, blue	WKFN 2,5/35 BLAU	56.703.0055.6
3	Ground block	WKFN 2,5 SL/35	56.703.9055.0
4	Duo feed-through block	WKFN 2,5 D1/2/35	56.703.5055.0
5	Duo feed-through block, blue	WKFN 2,5 D1/2/35 BLAU	56.703.5055.6
6	Duo ground block	WKFN 2,5 D1/2/SL/35	56.703.9355.0
7	Duo feed-through block	WKFN 2,5 D2/2/35	56.703.5155.0
8	Duo feed-through block, blue	WKFN 2,5 D2/2/35 BLAU	56.703.5155.6
9	Duo ground block	WKFN 2,5 D2/2/SL/35	56.703.9155.0
10	Multi-tier block	WKFN 2,5 E/35	56.703.7055.0
11	Multi-tier block, connected	WKFN 2,5 E/VB/35	56.703.6955.1
12	Multi-tier ground block	WKFN 2,5 E/SL/35	56.703.8955.0
13	Duo multi-tier block	WKFN 2,5 E1/2/35	56.703.6055.0
14	Duo multi-tier block, connected	WKFN 2,5 E1/2/VB/35	56.703.5955.1
15	Duo multi-tier ground block	WKFN 2,5 E1/2/SL/35	56.703.6255.0
16	Multi-tier block	WKFN 2,5 E3/35	56.703.3055.0
17	Multi-tier block, connected	WKFN 2,5 E3/VB/35	56.703.2955.1
18	Multi-tier ground block	WKFN 2,5 E3/SL/35	56.703.8855.0
19	Supply block	WKF 16/35/PV/WKFN	56.716.0353.0
20	Partition	TWFN 2,5	07.312.6855.0
21	Partition	TWFN 2,5 D1/2	07.312.7055.0
22	Cross connector, insulated	IVB WKF 2,5-2	Z7.280.6227.0
23	Cross connector, insulated	IVB WKF 2,5-5	Z7.280.6527.0
24	Cross connector, insulated	IVB WKF 2,5-6	Z7.280.6627.0
25	Wire entry guide	LELN 2,5/3 SCHWARZ	05.564.3955.0
26	Cover with warning symbol	ADFN 2,5/4 GELB	04.343.8253.8
27	Marking tag carrier, 2-fold	ST 5/2	04.243.0755.0
28	Test plug with insulated handle	ST 2/2,3	Z5.553.2921.0
29	Test adapter, snap-on	PS WKCF	Z1.299.9753.0
30	Mounting rail	35x27x7,5 EN 50022	98.300.0000.0
31	End clamp, without screw	WEF 1/35	Z5.523.9353.0
32	Marking strips	9705 A/5/10 B	04.845.xx53.0

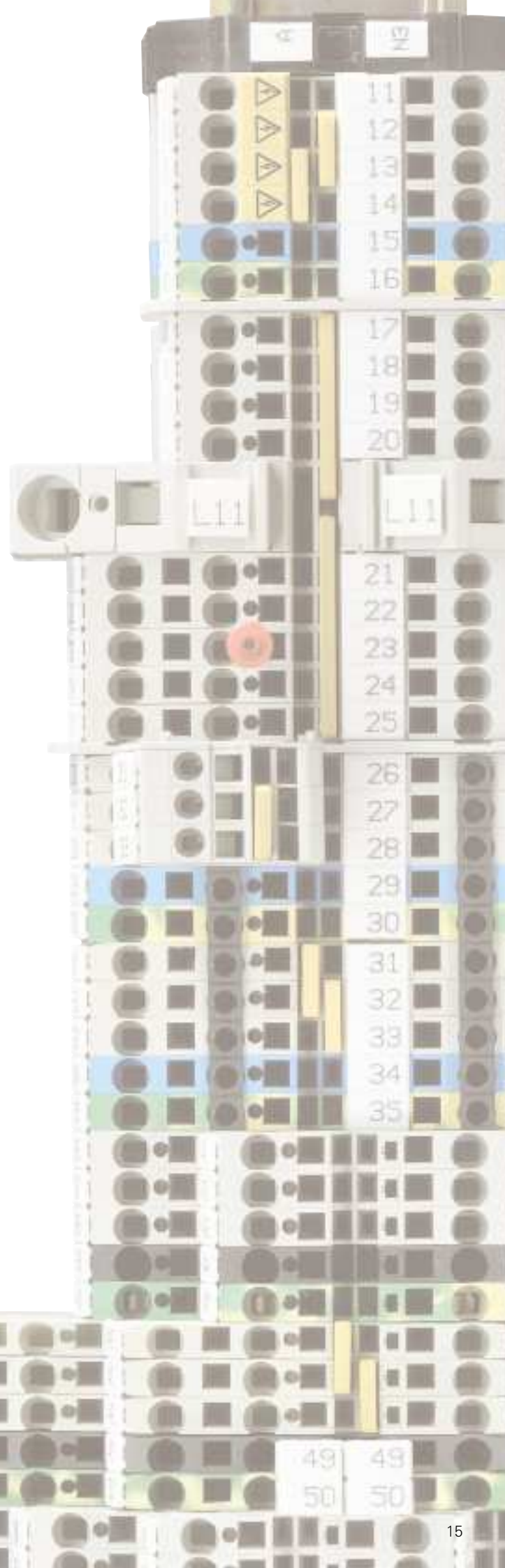

Duo feed-through blocks with tension spring connection

fasis

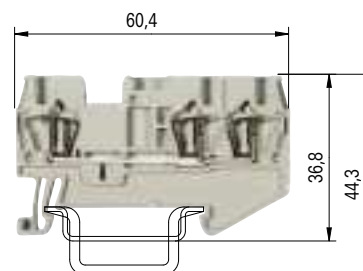
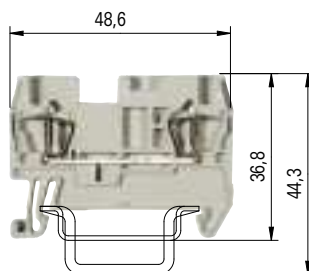

0344 Ex II 2GD

Ex e II

EN 60 947-7-1; 2002

UL ratings field/factory wiring

CSA ratings

KEMA 03 ATEX 2056 U1) EN 60079-0/EN 60079-7

Width Wire strip length

Approvals

WKF 1,5/35

fine-stranded solid V A
 0.08–1.5 mm² 0.08–1.5 mm² 500 V/6 kV/3 17.5
 No. 26-14 AWG 300 V 15
 No. 26-14 AWG 300 V 15
 0.14–1.5 mm² 0.14–1.5 mm² 440 V*) 17.5/16.5³⁾
 4 mm 10 mm

ATEX

WKF 1,5 D1/2/35

fine-stranded solid V A
 0.08–1.5 mm² 0.08–1.5 mm² 500 V/6 kV/3 17.5
 No. 26-14 AWG 300 V 15
 No. 26-14 AWG 300 V 15
 0.14–1.5 mm² 0.14–1.5 mm² 440 V*) 17.5/16.5³⁾
 4 mm 10 mm

ATEX

	Type	Part No.	Std. Pack	Type	Part No.	Std. Pack	
Feed-through block	gray	WKF 1,5/35	56.702.0053.0	50	WKF 1,5 D1/2/35	56.702.5053.0	50
Feed-through block	blue	WKF 1,5/35 BLAU	56.702.0053.6	50	WKF 1,5 D1/2/35 BLAU	56.702.5053.6	50
Accessories							
1. Mounting rail 35, 7.5 mm high	L = 2 m	35x27x7,5 EN 60715	98.300.0000.0	1	35x27x7,5 EN 60715	98.300.0000.0	1
Mounting rail 35, 15 mm high	L = 2 m	35x24x15 EN 60715	98.360.0000.0	1	35x24x15 EN 60715	98.360.0000.0	1
2. End clamp TS 35, with screw ²⁾	8 mm wide	9708/2 S35	Z5.522.8553.0	100	9708/2 S35	Z5.522.8553.0	100
End clamp TS 35, without screw	8 mm wide	WEF 1/35	Z5.523.9353.0	100	WEF 1/35	Z5.523.9353.0	100
3. End plate	gray	APF 1,5	07.312.8153.0	10	APF 1,5 D1/2	07.312.8353.0	10
	blue						
Segment end plate	gray				SAPF 1,5	07.312.8953.0	10
4. Partition plate	gray	TWF 1,5	07.312.8253.0	10	TWF 1,5 D1/2	07.312.8453.0	10
	blue						
5. Cross connector	2 pole	IVB WKF 1,5–2	Z7.268.0227.0	10	IVB WKF 1,5–2	Z7.268.0227.0	10
insulated	3 pole	IVB WKF 1,5–3	Z7.268.0327.0	10	IVB WKF 1,5–3	Z7.268.0327.0	10
	4 pole	IVB WKF 1,5–4	Z7.268.0427.0	10	IVB WKF 1,5–4	Z7.268.0427.0	10
	5 pole	IVB WKF 1,5–5	Z7.268.0527.0	10	IVB WKF 1,5–5	Z7.268.0527.0	10
	6 pole						
	7 pole						
	8 pole						
	10 pole	IVB WKF 1,5–10	Z7.268.1027.0	10	IVB WKF 1,5–10	Z7.268.1027.0	10
	20 pole	IVB WKF 1,5–20	Z7.268.2027.0	10	IVB WKF 1,5–20	Z7.268.2027.0	10
6. Wire entry guide	0.13–0.2 mm ²	LEL 1,5/1 WEISS	05.564.4253.0	10	LEL 1,5/1 WEISS	05.564.4253.0	10
	0.25–0.5 mm ²	LEL 1,5/2 GRAU	05.564.4353.0	10	LEL 1,5/2 GRAU	05.564.4353.0	10
	0.75–1.0 mm ²						
7. Cover with warning symbol over 4 blocks		ADF 1,5/5 GELB	04.343.6953.8	10	ADF 1,5/5 GELB	04.343.6953.8	10
8. Marking tag carrier, 2-fold							
9. Test adapter, modular							
10. Test plug							
11. Screwdriver, uninsulated		DIN 5264 B 0,4x2,5	06.502.4300.0	5	DIN 5264 B 0,4x2,5	06.502.4300.0	5
Marking accessories see page 76–79							

¹⁾ For maintaining the proper isolation distances, the open side of a feed-through terminal block as well as both sides of a jumper are to be covered by partitions.

²⁾ Follow the Ex installation instructions on the cover page.

³⁾ Do not use in Ex environments.

³⁾ Rated current when using cross connectors

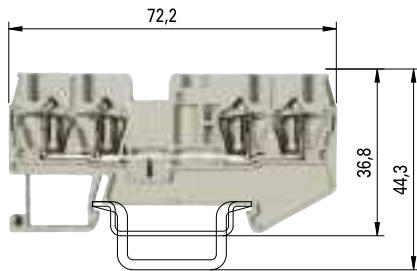

WKF 1,5 D2/2/35

fine-stranded	solid	V	A
0.08–1.5 mm ²	0.08–1.5 mm ²	500 V/6 kV/3	17.5
No. 26-14 AWG		300 V	15
No. 26-14 AWG		300 V	15
0.14–1.5 mm ²	0.14–1.5 mm ²	440 V ^(*)	17.5/16.5 ⁽³⁾
4 mm			10 mm

ATEX 

Type	Part No.	Std. Pack
WKF 1,5 D2/2/35	56.702.5153.0	50
WKF 1,5 D2/2/35 BLAU	56.702.5153.6	50
35x27x7,5 EN 60715	98.300.0000.0	1
35x24x15 EN 60715	98.360.0000.0	1
9708/2 S35	Z5.522.8553.0	100
WEF 1/35	Z5.523.9353.0	100
APF 1,5 D2/2	07.312.8553.0	10
SAPF 1,5	07.312.8953.0	10
TWF 1,5 D2/2	07.312.8653.0	10
IVB WKF 1,5–2	Z7.268.0227.0	10
IVB WKF 1,5–3	Z7.268.0327.0	10
IVB WKF 1,5–4	Z7.268.0427.0	10
IVB WKF 1,5–5	Z7.268.0527.0	10
IVB WKF 1,5–10	Z7.268.1027.0	10
IVB WKF 1,5–20	Z7.268.2027.0	10
LEL 1,5/1 WEISS	05.564.4253.0	10
LEL 1,5/2 GRAU	05.564.4353.0	10
ADF 1,5/5 GELB	04.343.6953.8	10
DIN 5264 B 0,4x2,5	06.502.4300.0	5

Duo ground blocks with tension spring connection

fasis

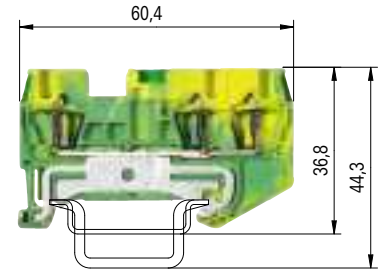
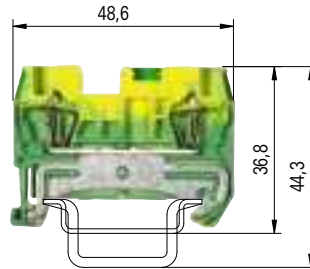

0344 Ex II 2GD

Ex e II

EN 60 947-7-2; 2002

UL ratings

field/factory wiring

CSA ratings

KEMA 03 ATEX 2056 U1) EN 60079-0/EN 60079-7

Width

Wire strip length

Approvals

WKF 1,5 SL/35

fine-stranded solid V A
 0.08–1.5 mm² 0.08–1.5 mm² 500 V/6 kV/3⁴⁾ ³⁾
 No. 26-14 AWG 300 V
 No. 26-14 AWG 300 V
 0.14–1.5 mm² 0.14–1.5 mm² *)
 4 mm 10 mm
 ATEX 

WKF 1,5 D1/2/SL/35

fine-stranded solid V A
 0.08–1.5 mm² 0.08–1.5 mm² 500 V/6 kV/3⁴⁾ ³⁾
 No. 26-14 AWG 300 V
 No. 26-14 AWG 300 V
 0.14–1.5 mm² 0.14–1.5 mm² *)
 4 mm 10 mm
 ATEX 

Ground block	Type	Part No.	Std. Pack	Type	Part No.	Std. Pack
yellow/green	WKF 1,5 SL/35	56.702.9053.0	50	WKF 1,5 D1/2/SL/35	56.702.9353.0	50
Accessories						
1. Mounting rail 35, 7.5 mm high	L = 2 m	35x27x7,5 EN 60715	98.300.0000.0	1	35x27x7,5 EN 60715	98.300.0000.0
Mounting rail 35, 15 mm high	L = 2 m	35x24x15 EN 60715	98.360.0000.0	1	35x24x15 EN 60715	98.360.0000.0
2. End clamp TS 35, with screw ²⁾	8 mm wide	9708/2 S35	Z5.522.8553.0	100	9708/2 S35	Z5.522.8553.0
End clamp TS 35, without screw	8 mm wide	WEF 1/35	Z5.523.9353.0	100	WEF 1/35	Z5.523.9353.0
3. End plate	gray	APF 1,5	07.312.8153.0	10	APF 1,5 D1/2	07.312.8353.0
	blue					
Segment end plate	gray				SAPF 1,5	07.312.8953.0
4. Partition plate	gray	TWF 1,5	07.312.8253.0	10	TWF 1,5 D1/2	07.312.8453.0
	blue					
5. Cross connector	2 pole					
insulated	3 pole					
	4 pole					
	5 pole					
	6 pole					
	7 pole					
	8 pole					
	10 pole					
	20 pole					
6. Wire entry guide	0.13–0.2 mm ²	LEL 1,5/1 WEISS	05.564.4253.0	10	LEL 1,5/1 WEISS	05.564.4253.0
	0.25–0.5 mm ²	LEL 1,5/2 GRAU	05.564.4353.0	10	LEL 1,5/2 GRAU	05.564.4353.0
	0.75–1.0 mm ²					
7. Cover with warning symbol over 4 blocks		ADF 1,5/5 GELB	04.343.6953.8	10	ADF 1,5/5 GELB	04.343.6953.8
8. Marking tag carrier, 2-fold						
9. Test adapter, modular						
10. Test plug						
11. Screwdriver, uninsulated		DIN 5264 B 0,4x2,5	06.502.4300.0	5	DIN 5264 B 0,4x2,5	06.502.4300.0
Marking accessories see page 76–79						

¹⁾ In order to maintain the proper isolation distances, the open side of a ground block is to be covered by an end plate.

²⁾ Do not use in Ex environments.

³⁾ For the current-carrying capabilities of the mounting rails see AT catalog section **facts & DATA**.

¹⁾ Follow the Ex installation instructions on the cover page.

⁴⁾ Ratings to adjacent feed-through blocks of the same series and size

Duo feed-through blocks with tension spring connection

fasis

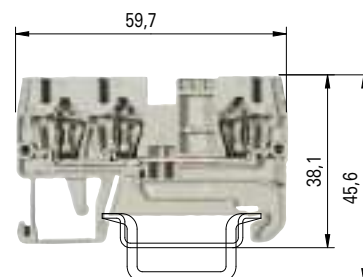
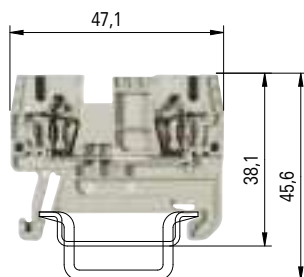

0344 Ex II 2GD IM2

Ex e I/II

EN 60 947-7-1:2002

UL ratings field/factory wiring

CSA ratings

PTB 04 ATEX 1051 U1) EN 60 079-0/EN 60 079-7

Width Wire strip length

Approvals

WKFN 2,5/35

fine-stranded solid V A
0.13–2.5 mm² 0.13–4 mm² 800 V/8 kV/3 24
No. 22-12 AWG 600 V 20
No. 24-12 AWG 600 V 24
0.2–2.5 mm² 0.13–4 mm² 550 V 22²⁾
5 mm 11 mm

PTB

WKFN 2,5 D1/2/35

fine-stranded solid V A
0.13–2.5 mm² 0.13–4 mm² 800 V/8 kV/3 24
No. 22-12 AWG 600 V 20
No. 24-12 AWG 600 V 24
0.2–2.5 mm² 0.13–4 mm² 550 V 22²⁾
5 mm 11 mm

PTB

	Type	Part No.	Std. Pack	Type	Part No.	Std. Pack	
Feed-through block	gray	WKFN 2,5/35	56.703.0055.0	100	WKFN 2,5 D1/2/35	56.703.5055.0	100
Feed-through block	blue	WKFN 2,5/35 BLAU	56.703.0055.6	100	WKFN 2,5 D1/2/35 BLAU	56.703.5055.6	100
Supply block	gray						
Accessories							
1. Mounting rail 35, 7.5 mm high	L = 2 m	35x27x7,5 EN 60715	98.300.0000.0	1	35x27x7,5 EN 60715	98.300.0000.0	1
Mounting rail 35, 15 mm high	L = 2 m	35x24x15 EN 60715	98.360.0000.0	1	35x24x15 EN 60715	98.360.0000.0	1
2. End clamp TS 35, with screw ²⁾	8 mm wide	9708/2 S35	Z5.522.8553.0	100	9708/2 S35	Z5.522.8553.0	100
End clamp TS 35, without screw	8 mm wide	WEF 1/35	Z5.523.9353.0	100	WEF 1/35	Z5.523.9353.0	100
3. End plate	gray	APFN 2,5	07.312.6755.0	10	APFN 2,5 D1/2	07.312.6955.0	10
	blue	APFN 2,5 BLAU	07.312.6755.6	10	APFN 2,5 D1/2 BLAU	07.312.6955.6	10
Segment end plate	gray						
4. Partition plate	gray	TWFN 2,5	07.312.6855.0	10	TWFN 2,5 D1/2	07.312.7055.0	10
	blue	TWFN 2,5 BLAU	07.312.6855.6	10	TWFN 2,5 D1/2 BLAU	07.312.7055.6	10
5. Cross connector	2 pole	IVB WKF 2,5–2	Z7.280.6227.0	10	IVB WKF 2,5–2	Z7.280.6227.0	10
insulated	3 pole	IVB WKF 2,5–3	Z7.280.6327.0	10	IVB WKF 2,5–3	Z7.280.6327.0	10
	4 pole	IVB WKF 2,5–4	Z7.280.6427.0	10	IVB WKF 2,5–4	Z7.280.6427.0	10
	5 pole	IVB WKF 2,5–5	Z7.280.6527.0	10	IVB WKF 2,5–5	Z7.280.6527.0	10
	6 pole	IVB WKF 2,5–6	Z7.280.6627.0	10	IVB WKF 2,5–6	Z7.280.6627.0	10
	7 pole	IVB WKF 2,5–7	Z7.280.6727.0	20	IVB WKF 2,5–7	Z7.280.6727.0	20
	8 pole	IVB WKF 2,5–8	Z7.280.6827.0	20	IVB WKF 2,5–8	Z7.280.6827.0	20
	9 pole	IVB WKF 2,5–9	Z7.280.6927.0	20	IVB WKF 2,5–9	Z7.280.6927.0	20
	10 pole	IVB WKF 2,5–10	Z7.280.7027.0	20	IVB WKF 2,5–10	Z7.280.7027.0	20
6. Wire entry guide	0.13–0.2 mm ²	LELN 2,5/1 WEISS	05.564.3755.0	100	LELN 2,5/1 WEISS	05.564.3755.0	100
	0.25–0.5 mm ²	LELN 2,5/2 GRAU	05.564.3855.0	100	LELN 2,5/2 GRAU	05.564.3855.0	100
	0.75–1.0 mm ²	LELN 2,5/3 SCHWARZ	05.564.3955.0	100	LELN 2,5/3 SCHWARZ	05.564.3955.0	100
7. Cover with warning symbol over 4 blocks		ADFN 2,5/4 GELB	04.343.8353.8	10	ADFN 2,5/4 GELB	04.343.8353.8	10
8. Marking tag carrier, 2-fold							
9. Test adapter, modular		PS WKC/F	Z1.299.9753.0	10	PS WKC/F	Z1.299.9753.0	10
10. Test plug		ST 2/2,3	Z5.553.2921.0	10	ST 2/2,3	Z5.553.2921.0	10
11. Screwdriver, uninsulated		DIN 5264 B 0,6x3,5	06.502.4000.0	5	DIN 5264 B 0,6x3,5	06.502.4000.0	5
Screwdriver, uninsulated, MINI		DIN 5264 B 0,6x3,5 M	06.502.5000.0	10	DIN 5264 B 0,6x3,5 M	06.502.5000.0	10
Marking accessories see page 76–79							

¹⁾ Follow the Ex installation instructions on the cover page.

²⁾ for 40 K and 45 K

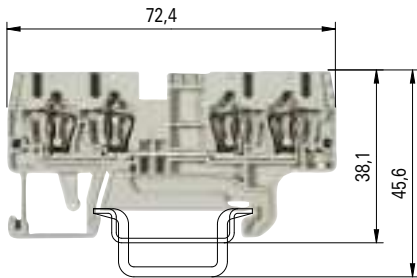

- Potential distribution with standard cross connector IVB WKF 2,5...
- Parallel connection of two cross connectors -> double jumpering
- Potential distributions are possible on one or both sides

Potential distribution	one side		both sides	
	single	double	single	double
I_{max}	48	68	72	76
I_{Nblock}	24	24	24	24

$$I_{max} = \sum I_n \leq \sum I_{Nblock}$$

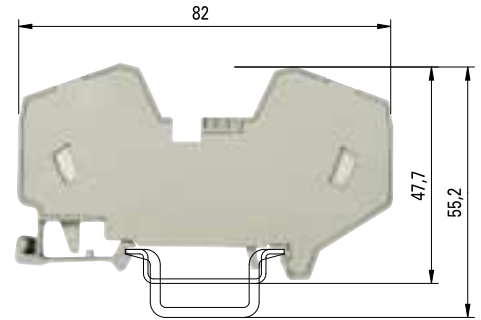

WKFN 2,5 D2/2/35

fine-stranded solid	V	A
0.13–2.5 mm ² 0.13–4 mm ²	800 V/8 kV/3	24
No. 22-12 AWG	600 V	20
No. 24-12 AWG	600 V	24
0.2–2.5 mm ² 0.13–4 mm ²	550 V	22 ²⁾
5 mm		11 mm

PIB

WKFN 16/35 PV/WKFN

fine-stranded solid/stranded	V	A
4–16 mm ² 4–16 mm ²	800 V/8 kV/3	76
No. 24-4 AWG	600 V	75
No. 12-4 AWG	600 V	78
4–16 mm ² 4–16 mm ²	690 V	64 A*
12 mm		15 mm

Type	Part No.	Std. Pack	Type	Part No.	Std. Pack
WKFN 2,5 D2/2/35	56.703.5155.0	100			
WKFN 2,5 D2/2/35 BLAU	56.703.5155.6	100			
			WKFN 16/35 PV/WKFN	56.716.0353.0	20
35x27x7,5 EN 60715	98.300.0000.0	1	35x27x7,5 EN 60715	98.300.0000.0	1
35x24x15 EN 60715	98.360.0000.0	1	35x24x15 EN 60715	98.360.0000.0	1
9708/2 S35	Z5.522.8553.0	100	9708/2 S35	Z5.522.8553.0	100
WEF 1/35	Z5.523.9353.0	100	WEF 1/35	Z5.523.9353.0	100
APFN 2,5 D2/2	07.312.7155.0	10			
APFN 2,5 D2/2 BLAU	07.312.7155.6	10			
TWFN 2,5 D2/2	07.312.7255.0	10			
TWFN 2,5 D2/2 BLAU	07.312.7255.6	10			
IVB WKF 2,5–2	Z7.280.6227.0	10	IVB WKF 2,5–2	Z7.280.6227.0	10
IVB WKF 2,5–3	Z7.280.6327.0	10	IVB WKF 2,5–3	Z7.280.6327.0	10
IVB WKF 2,5–4	Z7.280.6427.0	10	IVB WKF 2,5–4	Z7.280.6427.0	10
IVB WKF 2,5–5	Z7.280.6527.0	10	IVB WKF 2,5–5	Z7.280.6527.0	10
IVB WKF 2,5–6	Z7.280.6627.0	10	IVB WKF 2,5–6	Z7.280.6627.0	10
IVB WKF 2,5–7	Z7.280.6727.0	20	IVB WKF 2,5–7	Z7.280.6727.0	20
IVB WKF 2,5–8	Z7.280.6827.0	20	IVB WKF 2,5–8	Z7.280.6827.0	20
IVB WKF 2,5–9	Z7.280.6927.0	20	IVB WKF 2,5–9	Z7.280.6927.0	20
IVB WKF 2,5–10	Z7.280.7027.0	20	IVB WKF 2,5–10	Z7.280.7027.0	20
LELN 2,5/1 WEISS	05.564.3755.0	100			
LELN 2,5/2 GRAU	05.564.3855.0	100			
LELN 2,5/3 SCHWARZ	05.564.3955.0	100			
ADFN 2,5/4 GELB	04.343.8353.8	10	ADFN 16/4 GELB	04.343.6653.8	10
PS WKC/F	Z1.299.9753.0	10			
ST 2/2,3	Z5.553.2921.0	10	ST 2/2,3	Z5.553.2921.0	10
DIN 5264 B 0,6x3,5	06.502.4000.0	5	DIN 5264 B 1,0x5,5	06.502.4200.0	5
DIN 5264 B 0,6x3,5 M	06.502.5000.0	10			

* Type-specific output currents upon request; KEMA 01 ATEX 2087 U¹⁾

Duo ground blocks with tension spring connection

fasis SIS

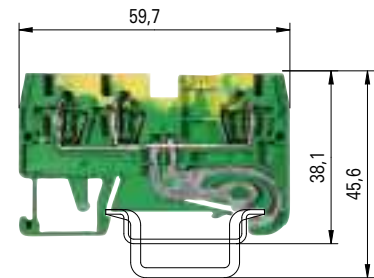
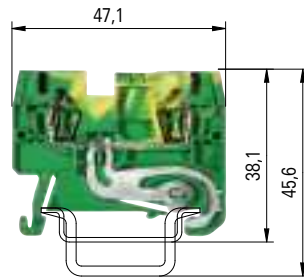

0344 Ex II 2GD IM2

Ex e I/II

EN 60 947-7-2:2002

UL ratings

field/factory wiring

CSA ratings

PTB 04 ATEX 1051 U1) EN 60 079-0/EN 60 079-7

Width

Wire strip length

Approvals

WKFN 2,5 SL/35

fine-stranded solid V A
 0.13–2.5 mm² 0.13–4 mm² 800 V/8 kV/3⁴⁾ 3)
 No. 22-12 AWG 600 V
 No. 24-12 AWG 600 V
 0.2–2.5 mm² 0.13–4 mm²
 5 mm 11 mm
 PTB AEx Ex

WKFN 2,5 D1/2/SL/35

fine-stranded solid V A
 0.13–2.5 mm² 0.13–4 mm² 800 V/8 kV/3⁴⁾ 3)
 No. 22-12 AWG 600 V
 No. 24-12 AWG 600 V
 0.2–2.5 mm² 0.13–4 mm²
 5 mm 11 mm
 PTB AEx Ex

Ground block	green/yellow	Type	Part No.	Std. Pack	Type	Part No.	Std. Pack
		WKFN 2,5 SL/35	56.703.9055.0	100	WKFN 2,5 D1/2/SL/35	56.703.9355.0	100
Accessories							
1. Mounting rail 35, 7.5 mm high	L = 2 m	35x27x7,5 EN 60715	98.300.0000.0	1	35x27x7,5 EN 60715	98.300.0000.0	1
Mounting rail 35, 15 mm high	L = 2 m	35x24x15 EN 60715	98.360.0000.0	1	35x24x15 EN 60715	98.360.0000.0	1
2. End clamp TS 35, with screw	8 mm wide	9708/2 S35	Z5.522.8553.0	100	9708/2 S35	Z5.522.8553.0	100
End clamp TS 35, without screw	8 mm wide	WEF 1/35	Z5.523.9353.0	100	WEF 1/35	Z5.523.9353.0	100
3. End plate	gray						
	blue						
	green/yellow	APFN 2,5 GRÜN	07.312.6755.7	10	APFN 2,5 D1/2 GRÜN	07.312.6955.7	10
4. Partition plate	gray						
	blue						
5. Cross connector	2 pole						
insulated (jumper bar)	3 pole						
	4 pole						
	5 pole						
	6 pole						
	7 pole						
	8 pole						
	9 pole						
	10 pole						
6. Wire entry guide	0.13–0.2 mm ²	LELN 2,5/1 WEISS	05.564.3755.0	100	LELN 2,5/1 WEISS	05.564.3755.0	100
	0.25–0.5 mm ²	LELN 2,5/2 GRAU	05.564.3855.0	100	LELN 2,5/2 GRAU	05.564.3855.0	100
	0.75–1.0 mm ²	LELN 2,5/3 SCHWARZ	05.564.3955.0	100	LELN 2,5/3 SCHWARZ	05.564.3955.0	100
7. Cover with warning symbol over 4 blocks		ADFN 2,5/4 GELB	04.343.8353.8	10	ADFN 2,5/4 GELB	04.343.8353.8	10
8. Marking tag carrier, 2-fold							
9. Test adapter, modular							
10. Test plug							
11. Screwdriver, uninsulated		DIN 5264 B 0,6x3,5	06.502.4000.0	5	DIN 5264 B 0,6x3,5	06.502.4000.0	5
Screwdriver, uninsulated, MINI		DIN 5264 B 0,6x3,5 M	06.502.5000.0	10	DIN 5264 B 0,6x3,5 M	06.502.5000.0	10
Marking accessories see page 76–79							

¹⁾ Follow the Ex installation instructions on the cover page. ⁴⁾ Ratings to adjacent feed-through blocks of the same series and size

³⁾ For the current-carrying capabilities of the mounting rails see AT catalog section **facts & DATA**.

fasis

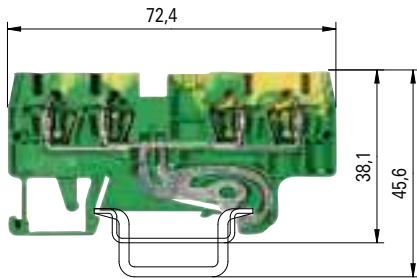

WKFN 2,5 D2/2/SL/35

fine-stranded solid V A
 0.13–2.5 mm² 0.13–4 mm² 800 V/8 kV/3⁴⁾ 3)
 No. 22-12 AWG 600 V
 No. 24-12 AWG 600 V
 0.2–2.5 mm² 0.13–4 mm²
 5 mm 11 mm
 PTB

Type	Part No.	Std. Pack
WKFN 2,5 D2/2/SL/35	56.703.9155.0	100
35x27x7,5 EN 60715	98.300.0000.0	1
35x24x15 EN 60715	98.360.0000.0	1
9708/2 S35	Z5.522.8553.0	100
WEF 1/35	Z5.523.9353.0	100
APFN 2,5 D2/2 GRÜN	07.312.7155.7	10
LELN 2,5/1 WEISS	05.564.3755.0	100
LELN 2,5/2 GRAU	05.564.3855.0	100
LELN 2,5/3 SCHWARZ	05.564.3955.0	100
ADFN 2,5/4 GELB	04.343.8353.8	10
DIN 5264 B 0,6x3,5	06.502.4000.0	5
DIN 5264 B 0,6x3,5 M	06.502.5000.0	10

Duo feed-through blocks with tension spring connection

fasis

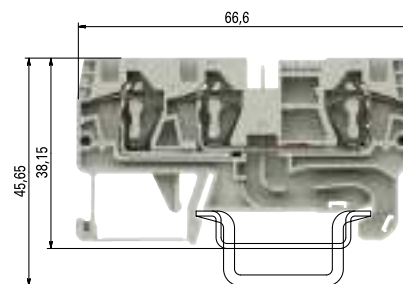
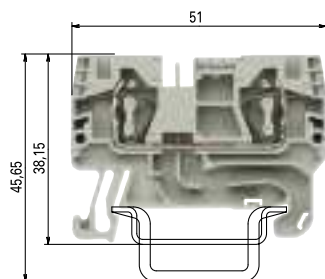

0344 Ex II 2GD IM2

Ex e I/II

EN 60 947-7-1:2002

UL ratings field/factory wiring

CSA ratings

PTB 05 ATEX 1104 U1) EN 60 079-0/EN 60 079-7

Width Wire strip length

Approvals

WKFN 4 /35

fine-stranded	solid	V	A
0.13–4 mm ²	0.13–6 mm ²	800 V/8 kV/3	32
No. 24-10 AWG		600 V	30
No. 24-10 AWG		600 V	32
0.13–4 mm ²	0.2–6 mm ²	690 V	28/30 ²⁾
6 mm			11 mm

PTB

WKFN 4 D1/2/35

fine-stranded	solid	V	A
0.13–4 mm ²	0.13–6 mm ²	800 V/8 kV/3	32
No. 24-10 AWG		600 V	30
No. 24-10 AWG		600 V	32
0.13–4 mm ²	0.2–6 mm ²	550 V	28/30 ²⁾
6 mm			11 mm

PTB

		Type	Part No.	Std. Pack	Type	Part No.	Std. Pack
Feed-through block	gray	WKFN 4/35	56.704.0055.0	100	WKFN 4 D1/2/35	56.704.5055.0	100
Feed-through block	blue	WKFN 4/35 BLAU	56.704.0055.6	100	WKFN 4 D1/2/35 BLAU	56.704.5055.6	100
Supply block	gray						
Accessories							
1. Mounting rail 35, 7.5 mm high	L = 2 m	35x27x7.5 EN 60715	98.300.0000.0	1	35x27x7.5 EN 60715	98.300.0000.0	1
Mounting rail 35, 15 mm high	L = 2 m	35x24x15 EN 60715	98.360.0000.0	1	35x24x15 EN 60715	98.360.0000.0	1
2. End clamp TS 35, with screw	8 mm wide	9708/2 S35	Z5.522.8553.0	100	9708/2 S35	Z5.522.8553.0	100
End clamp TS 35, without screw	8 mm wide	WEF 1/35	Z5.523.9353.0	100	WEF 1/35	Z5.523.9353.0	100
3. End plate	gray	APFN 4	07.312.9255.0	10	APFN 4 D1/2	07.312.9455.0	10
	blue	APFN 4 BLAU	07.312.9255.6	10	APFN 4 D1/2 BLAU	07.312.9455.6	10
Segment end plate	gray						
4. Partition plate	gray	TWFN 4	07.312.9355.0	10	TWFN 4 D1/2	07.312.9555.0	10
	blue	TWFN 4 BLAU	07.312.9355.6	10	TWFN 4 D1/2 BLAU	07.312.9555.6	10
5. Cross connector	2 pole	IVB WKF 4–2	Z7.261.1227.0	10	IVB WKF 4–2	Z7.261.1227.0	10
insulate	3 pole	IVB WKF 4–3	Z7.261.1327.0	10	IVB WKF 4–3	Z7.261.1327.0	10
	4 pole	IVB WKF 4–4	Z7.261.1427.0	10	IVB WKF 4–4	Z7.261.1427.0	10
	5 pole	IVB WKF 4–5	Z7.261.1527.0	10	IVB WKF 4–5	Z7.261.1527.0	10
	6 pole	IVB WKF 4–6	Z7.261.1627.0	10	IVB WKF 4–6	Z7.261.1627.0	10
	7 pole	IVB WKF 4–7	Z7.261.1727.0	20	IVB WKF 4–7	Z7.261.1727.0	20
	8 pole	IVB WKF 4–8	Z7.261.1827.0	20	IVB WKF 4–8	Z7.261.1827.0	20
	9 pole	IVB WKF 4–9	Z7.261.1927.0	20	IVB WKF 4–9	Z7.261.1927.0	20
	10 pole	IVB WKF 4–10	Z7.261.2027.0	20	IVB WKF 4–10	Z7.261.2027.0	20
6. Vertical Jumper, insulated	1 pole						
7. Wire entry guide	0,13–0,2 mm ²	LEL 4/1 WEISS	05.561.8553.0	100	LEL 4/1 WEISS	05.561.8553.0	100
	0,25–0,5 mm ²	LEL 4/2 GRAU	05.561.8653.0	100	LEL 4/2 GRAU	05.561.8653.0	100
	0,75–1,0 mm ²	LEL 4/3 SCHWARZ	05.561.8753.0	100	LEL 4/3 SCHWARZ	05.561.8753.0	100
8. Cover with warning symbol over 4 blocks		ADF 4/4 GELB	04.343.6153.8	10	ADF 4/4 GELB	04.343.6153.8	10
9. Marking tag carrier, 2-fold							
10. Test adapter, modular		PS WKC/F	Z1.299.9753.0	10	PS WKC/F	Z1.299.9753.0	10
11. Test plug		ST 2/2,3	Z5.553.2921.0	10	ST 2/2,3	Z5.553.2921.0	10
12. Screwdriver, uninsulated		DIN 5264 B 0,6x3,5	06.502.4000.0	5	DIN 5264 B 0,6x3,5	06.502.4000.0	5
Screwdriver, uninsulated, MINI		DIN 5264 B 0,6x3,5 M	06.502.5000.0	10	DIN 5264 B 0,6x3,5 M	06.502.5000.0	10
Marking accessories see page 76–79							

¹⁾ Follow the Ex installation instructions on the cover page..

²⁾ 1. value at 40 K / 2. value at 45 K

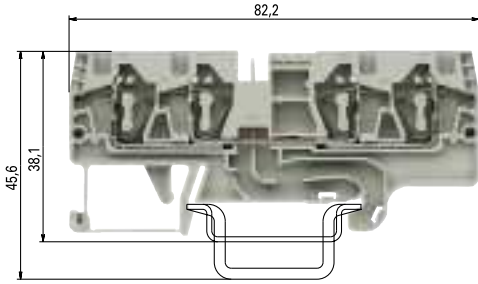

- Potential distribution with standard cross connector IVB WKF 4...
- Parallel connection of two cross connectors -> double jumpering
- Potential distributions are possible on one or both sides

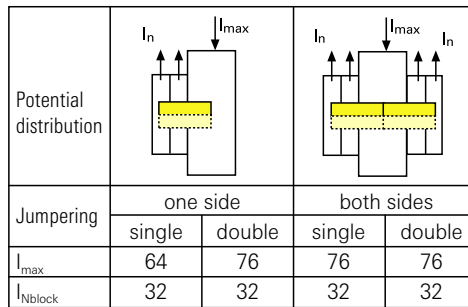

$$I_{max} = \sum I_n \leq \sum I_{Nblock}$$

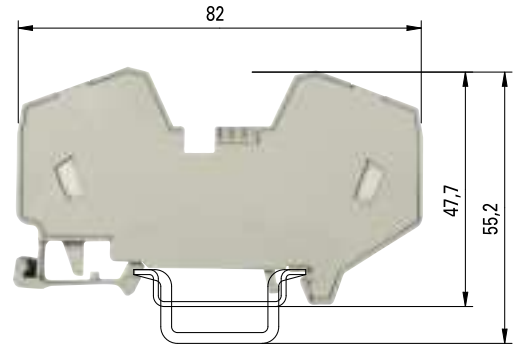

WKFN 4 D2/2/35

fine-stranded	solid	V	A
0.13-4 mm ²	0.13-6 mm ²	800 V/8 kV/3	32
No. 24-10 AWG		600 V	30
No. 24-10 AWG		600 V	32
0.13-4 mm ²	0.2-6 mm ²	550 V	28/30 ²⁾
6 mm			11 mm



WKFN 16/35 PV/WKFN

fine-stranded	solid/stranded	V	A
4-16 mm ²	4-16 mm ²	800 V/8 kV/3	76
No. 24-4 AWG		600 V	75
No. 12-4 AWG		600 V	78
4-16 mm ²	4-16 mm ²	690 V	64*
12 mm			15 mm



Type	Part No.	Std. Pack	Type	Part No.	Std. Pack
WKFN 4 D2/2/35	56.704.5155.0	100			
WKFN 4 D2/2/35 BLAU	56.704.5155.6	100			
			WKFN 16/35 PV/WKFN	56.716.0353.0	20
35x27x7,5 EN 60715	98.300.0000.0	1	35x27x7,5 EN 60715	98.300.0000.0	1
35x24x15 EN 60715	98.360.0000.0	1	35x24x15 EN 60715	98.360.0000.0	1
9708/2 S35	Z5.522.8553.0	100	9708/2 S35	Z5.522.8553.0	100
WEF 1/35	Z5.523.9353.0	100	WEF 1/35	Z5.523.9353.0	100
APFN 4 D2/2	07.312.9055.0	10			
APFN 4 D2/2 BLAU	07.312.9055.6	10			
TWFN 4 D2/2	07.312.9155.0	10			
TWFN 4 D2/2 BLAU	07.312.9155.6	10			
IVB WKF 4-2	Z7.261.1227.0	10	IVB WKF 4-2	Z7.261.1227.0	10
IVB WKF 4-3	Z7.261.1327.0	10	IVB WKF 4-3	Z7.261.1327.0	10
IVB WKF 4-4	Z7.261.1427.0	10	IVB WKF 4-4	Z7.261.1427.0	10
IVB WKF 4-5	Z7.261.1527.0	10	IVB WKF 4-5	Z7.261.1527.0	10
IVB WKF 4-6	Z7.261.1627.0	10	IVB WKF 4-6	Z7.261.1627.0	10
IVB WKF 4-7	Z7.261.1727.0	20	IVB WKF 4-7	Z7.261.1727.0	20
IVB WKF 4-8	Z7.261.1827.0	20	IVB WKF 4-8	Z7.261.1827.0	20
IVB WKF 4-9	Z7.261.1927.0	20	IVB WKF 4-9	Z7.261.1927.0	20
IVB WKF 4-10	Z7.261.2027.0	20	IVB WKF 4-10	Z7.261.2027.0	20
LEL 4/1 WEISS	05.561.8553.0	100			
LEL 4/2 GRAU	05.561.8653.0	100			
LEL 4/3 SCHWARZ	05.561.8753.0	100			
ADF 4/4 GELB	04.343.6153.8	10	ADF 16/4 GELB	04.343.6653.8	10
PS WKC/F	Z1.299.9753.0	10			
ST 2/2,3	Z5.553.2921.0	10	ST 2/2,3	Z5.553.2921.0	10
DIN 5264 B 0,6x3,5	06.502.4000.0	5	DIN 5264 B 1,0x5,5	06.502.4200.0	5
DIN 5264 B 0,6x3,5 M	06.502.5000.0	10			

* Type-specific output currents upon request; KEMA 01 ATEX 2087 U¹⁾

Duo ground blocks with tension spring connection

fasis SIS

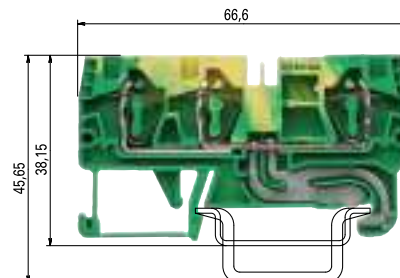
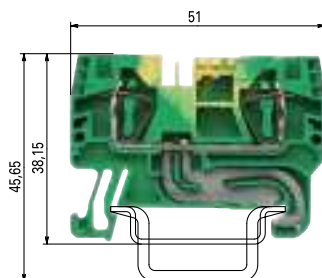

0344 Ex II 2GD IM2

Ex e I/II

EN 60 947-7-2:2002

UL ratings field/factory wiring

CSA ratings

PTB 05 ATEX 1104 U1) EN 60 079-0/EN 60 079-7

Width Wire strip length

Approvals

WKFN 4 SL/35

fine-stranded solid V A
 0.13–4 mm² 0.13–6 mm² 800 V/8 kV/3²⁾
 No. 24-10 AWG 600 V
 No. 24-10 AWG 600 V
 0.13–4 mm² 0.2–6 mm²
 6 mm 11 mm

WKFN 4 D1/2/SL/35

fine-stranded solid V A
 0.13–4 mm² 0.13–6 mm² 800 V/8 kV/3²⁾
 No. 24-10 AWG 600 V
 No. 24-10 AWG 600 V
 0.13–4 mm² 0.2–6 mm²
 6 mm 11 mm

Ground block	green/yellow	Type	Part No.	Std. Pack	Type	Part No.	Std. Pack
		WKFN 4 SL/35	56.704.9055.0	100	WKFN 4 D1/2/SL/35	56.704.9355.0	100
Accessories							
1. Mounting rail 35, 7.5 mm high	L = 2 m	35x27x7,5 EN 60715	98.300.0000.0	1	35x27x7,5 EN 60715	98.300.0000.0	1
Mounting rail 35, 15 mm high	L = 2 m	35x24x15 EN 60715	98.360.0000.0	1	35x24x15 EN 60715	98.360.0000.0	1
2. End clamp TS 35, with screw	8 mm wide	9708/2 S35	Z5.522.8553.0	100	9708/2 S35	Z5.522.8553.0	100
End clamp TS 35, without screw	8 mm wide	WEF 1/35	Z5.523.9353.0	100	WEF 1/35	Z5.523.9353.0	100
3. End plate	gray						
	blue						
	green	APFN 4 GRÜN	07.312.9255.7	10	APFN 4 D1/2 GRÜN	07.312.9455.7	10
4. Partition plate	gray						
	blue						
5. Cross connector	2 pole						
insulated	3 pole						
	4 pole						
	5 pole						
	6 pole						
	7 pole						
	8 pole						
	9 pole						
	10 pole						
6. Vertical cross connector, insulated	1 pole						
7. Wire entry guide	0,13–0,2 mm ²	LEL 4/1 WEISS	05.561.8553.0	100	LEL 4/1 WEISS	05.561.8553.0	100
	0,25–0,5 mm ²	LEL 4/2 GRAU	05.561.8653.0	100	LEL 4/2 GRAU	05.561.8653.0	100
	0,75–1,0 mm ²	LEL 4/3 SCHWARZ	05.561.8753.0	100	LEL 4/3 SCHWARZ	05.561.8753.0	100
8. Cover with warning symbol over 4 blocks		ADF 4/4 GELB	04.343.6153.8	10	ADF 4/4 GELB	04.343.6153.8	10
9. Marking tag carrier, 2-fold							
10. Test adapter, modular							
11. Test plug		ST 2/2,3	Z5.553.2921.0	10	ST 2/2,3	Z5.553.2921.0	10
12. Screwdriver, uninsulated		DIN 5264 B 0,6x3,5	06.502.4000.0	5	DIN 5264 B 0,6x3,5	06.502.4000.0	5
Screwdriver, uninsulated, MINI		DIN 5264 B 0,6x3,5 M	06.502.5000.0	10	DIN 5264 B 0,6x3,5 M	06.502.5000.0	10
Marking accessories see page 76–79							

¹⁾ Follow the Ex installation instructions on the cover page. ²⁾ For the current-carrying capabilities of the mounting rails see AT catalog section **facts** & DATA.

Duo feed-through blocks with tension spring connection

fasis

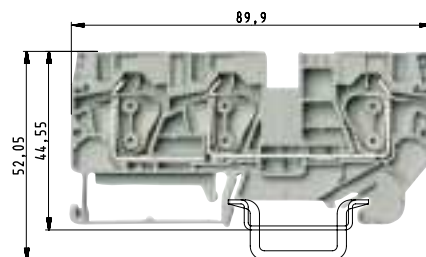
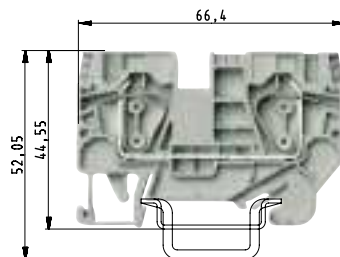

0344 Ex II 2GD IM2

Ex e I/II

EN 60 947-7-1:2002

UL ratings field/factory wiring

CSA ratings

PTB 06 ATEX 1075 U¹⁾ EN 60 079-0/EN 60 079-7

Width Wire strip length

Approvals

WKFN 6/35

fine-stranded	solid	V	A
0.2–6 mm ²	1.5–10 mm ²	800 V/8 kV/3	41
No. 24-8 AWG		600 V	50
No. 24-8 AWG		600 V	41
0.2–6 mm ²	1.5–10 mm ²	550 V	39/41*
8 mm			12 mm



WKFN 6 D1/2/35

fine-stranded	solid	V	A
0.2–6 mm ²	1.5–10 mm ²	800 V/8 kV/3	41
No. 24-8 AWG		600 V	50
No. 24-8 AWG		600 V	41
0.2–6 mm ²	1.5–10 mm ²	550 V	39/41*
8 mm			12 mm



	Type	Part No.	Std. Pack	Type	Part No.	Std. Pack
Feed-through block gray	WKFN 6/35	56.706.0055.0	100	WKFN 6 D1/2/35	56.706.5055.0	100
Feed-through block blue	WKFN 6/35 BLAU	56.706.0055.6	100	WKFN 6 D1/2/35 BLAU	56.706.5055.6	100
Ground block green/yellow						
Accessories						
1. Mounting rail 35, 7.5 mm high L = 2 m	35x27x7.5 EN 60715	98.300.0000.0	1	35x27x7.5 EN 60715	98.300.0000.0	1
Mounting rail 35, 15 mm high L = 2 m	35x24x15 EN 60715	98.360.0000.0	1	35x24x15 EN 60715	98.360.0000.0	1
2. End clamp TS 35, with screw 8 mm wide	9708/2 S35	Z5.522.8553.0	100	9708/2 S35	Z5.522.8553.0	100
End clamp TS 35, without screw 8 mm wide	WEF 1/35	Z5.523.9353.0	100	WEF 1/35	Z5.523.9353.0	100
3. End plate gray	APFN 6	07.313.0455.0	10	APFN 6 D1/2	07.313.0655.0	10
blue	APFN 6 BLAU	07.313.0455.6	10	APFN 6 D1/2 BLAU	07.313.0655.6	10
green						
4. Partition plate gray	TWFN 6	07.313.0555.0	10	TWFN 6 D1/2	07.313.0755.0	10
blue	TWFN 6 BLAU	07.313.0555.6	10	TWFN 6 D1/2 BLAU	07.313.0755.6	10
5. Cross connector 2 pole	IVB WKFN 6–2	Z7.282.5227.0	10	IVB WKFN 6–2	Z7.282.5227.0	10
insulated 3 pole	IVB WKFN 6–3	Z7.282.5327.0	10	IVB WKFN 6–3	Z7.282.5327.0	10
4 pole	IVB WKFN 6–4	Z7.282.5427.0	10	IVB WKFN 6–4	Z7.282.5427.0	10
5 pole	IVB WKFN 6–5	Z7.282.5527.0	10	IVB WKFN 6–5	Z7.282.5527.0	10
6 pole						
7 pole						
8 pole						
9 pole						
10 pole						
6. Reducing jumper, WKFN 35 to WKFN 10						
Reducing jumper, WKFN 35 to WKFN 16						
Reducing jumper, WKFN 16 to WKFN 10						
7. Cover with warning symbol for 4 terminals	ADF 6/4 GELB	04.343.6253.8	10	ADF 6/4 GELB	04.343.6253.8	10
8. Test adapter modular						
9. Test plug	ST 2/2,3	Z5.553.2921.0	10	ST 2/2,3	Z5.553.2921.0	10
10. Screwdriver, uninsulated	DIN 5264 B 0,8x4	06.502.4100.0	5	DIN 5264 B 0,8x4	06.502.4100.0	5
Marking accessories see page 76–79						

¹⁾ Follow the Ex installation instructions on the cover page
* 1. value at 40 K/2. value at 45 K

²⁾ For the current-carrying capabilities of the mounting rails see AT catalog section **facts & DATA**.

** When cross connectors are used according to EN 60079-0 and EN 60079-7, the current must be reduced to max. 3.5 A.

Duo ground blocks with tension spring connection

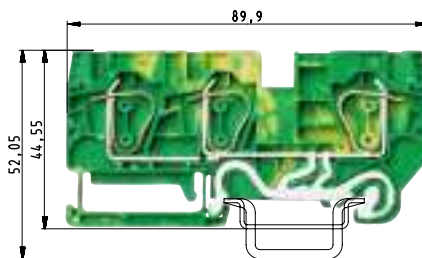
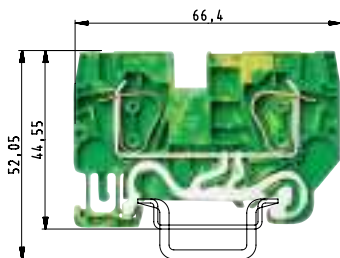

WKFN 6 SL/35

fine-stranded solid V A
 0.2–6 mm² 1.5–10 mm² 800 V/8 kV/3
 No. 24-8 AWG 600 V
 No. 24-8 AWG 600 V
 0.2–6 mm² 1.5–10 mm²
 8 mm 12 mm



WKFN 6 D1/2/SL/35

fine-stranded solid V A
 0.2–6 mm² 1.5–10 mm² 800 V/8 kV/3
 No. 24-8 AWG 600 V 50
 No. 24-8 AWG 600 V
 0.2–6 mm² 1.5–10 mm²
 8 mm 12 mm



Type	Part No.	Std. Pack	Type	Part No.	Std. Pack
WKFN 6 SL/35	56.706.9055.0	100	WKFN 6 D1/2/SL/35	56.706.9355.0	100
35x27x7,5 EN 60715	98.300.0000.0	1	35x27x7,5 EN 60715	98.300.0000.0	1
35x24x15 EN 60715	98.360.0000.0	1	35x24x15 EN 60715	98.360.0000.0	1
9708/2 S35	Z5.522.8553.0	100	9708/2 S35	Z5.522.8553.0	100
WEF 1/35	Z5.523.9353.0	100	WEF 1/35	Z5.523.9353.0	100
APFN 6 GRÜN	07.313.0455.7	10	APFN 6 D1/2 GRÜN	07.313.0655.7	10
IVB WKFN 6–2	Z7.282.5227.0	10	IVB WKFN 6–2	Z7.282.5227.0	10
IVB WKFN 6–3	Z7.282.5327.0	10	IVB WKFN 6–3	Z7.282.5327.0	10
IVB WKFN 6–4	Z7.282.5427.0	10	IVB WKFN 6–4	Z7.282.5427.0	10
IVB WKFN 6–5	Z7.282.5527.0	10	IVB WKFN 6–5	Z7.282.5527.0	10
ADF 6/4 GELB	04.343.6253.8	10	ADF 6/4 GELB	04.343.6253.8	10
ST 2/2,3	Z5.553.2921.0	10	ST 2/2,3	Z5.553.2921.0	10
DIN 5264 B 0,8x4	06.502.4100.0	5	DIN 5264 B 0,8x4	06.502.4100.0	5

Duo feed-through blocks with tension spring connection

fasis

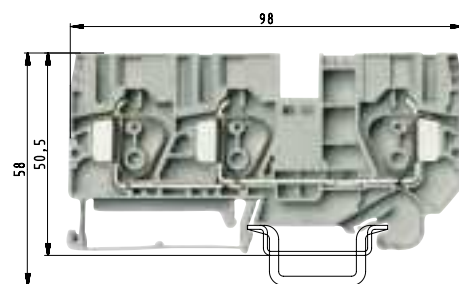
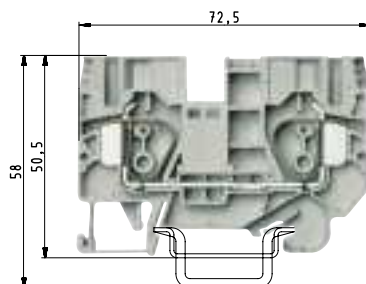

0344 Ex II 2GD IM2

Ex e I/II

EN 60 947-7-1:2002

UL ratings field/factory wiring

CSA ratings

PTB 06 ATEX 1075 U¹⁾ EN 60 079-0/EN 60 079-7

Width Wire strip length

Approvals

WKFN 10/35

fine-stranded	solid/stranded	V	A
0.2–10 mm ²	1.5–16 mm ²	800 V/8 kV/3	57
No. 16-6 AWG		600 V	60
No. 16-6 AWG		600 V	65
0.2–10 mm ²	1.5–16 mm ²	550 V	52/57*
10 mm			15 mm



WKFN 10 D1/2/35

fine-stranded	solid/stranded	V	A
0.2–10 mm ²	1.5–16 mm ²	800 V/8 kV/3	57
No. 16-6 AWG		600 V	60
No. 16-6 AWG		600 V	65
0.2–10 mm ²	1.5–16 mm ²	550 V	52/57*
10 mm			15 mm



	Type	Part No.	Std. Pack	Type	Part No.	Std. Pack
Feed-through block gray	WKFN 10/35	56.710.0055.0	50	WKFN 10 D1/2/35	56.710.5055.0	50
Feed-through block blue	WKFN 10/35 BLAU	56.710.0055.6	50	WKFN 10 D1/2/35 BLAU	56.710.5055.6	50
Ground block green/yellow						
Accessories						
1. Mounting rail 35, 7.5 mm high L = 2 m	35x27x7,5 EN 60715	98.300.0000.0	1	35x27x7,5 EN 60715	98.300.0000.0	1
Mounting rail 35, 15 mm high L = 2 m	35x24x15 EN 60715	98.360.0000.0	1	35x24x15 EN 60715	98.360.0000.0	1
2. End clamp TS 35, with screw 8 mm wide	9708/2 S35	Z5.522.8553.0	100	9708/2 S35	Z5.522.8553.0	100
End clamp TS 35, without screw 8 mm wide	WEF 1/35	Z5.523.9353.0	100	WEF 1/35	Z5.523.9353.0	100
3. End plate gray	APFN 10	07.313.0855.0	10	APFN 10 D1/2	07.313.1055.0	10
blue	APFN 10 BLAU	07.313.0855.6	10	APFN 10 D1/2 BLAU	07.313.1055.6	10
green						
4. Partition plate gray	TWFN 10	07.313.0955.0	10	TWFN 10 D1/2	07.313.1155.0	10
blue	TWFN 10 BLAU	07.313.0955.6	10	TWFN 10 D1/2 BLAU	07.313.1155.6	10
5. Cross connector 2 pole	IVB WKF 10–2	Z7.283.8227.0	10	IVB WKF 10–2	Z7.283.8227.0	10
insulated 3 pole						
4 pole						
5 pole						
6 pole						
7 pole						
8 pole						
9 pole						
10 pole						
6. Reducing jumper, WKFN 35 to WKFN 10 ²⁾	IVB WKFN 35R10	Z7.285.6427.0	10	IVB WKFN 35R10	Z7.285.6427.0	10
Reducing jumper, WKFN 35 to WKFN 16 ²⁾						
Reducing jumper, WKFN 16 to WKFN 10 ²⁾	IVB WKFN 16R10	Z7.284.4327.0	10	IVB WKFN 16R10	Z7.284.4327.0	10
7. Cover with warning symbol for 4 terminals	ADF 10/4 GELB	04.343.6453.8	10	ADF 10/4 GELB	04.343.6453.8	10
8. Test adapter modular						
9. Test plug	ST 2/2,3	Z5.553.2921.0	10	ST 2/2,3	Z5.553.2921.0	10
10. Screwdriver, uninsulated	DIN 5264 B 1x5,5	06.502.4200.0	5	DIN 5264 B 1x5,5	06.502.4200.0	5
Marking accessories see page. 76–79						

¹⁾ Follow the Ex installation instructions on the cover page
* 1. value at 40 K/2. value at 45 K

²⁾ For the current-carrying capabilities of the mounting rails see AT catalog section **facts & DATA**. ³⁾ Pls. note that the current must be reduced for EX applications
** When cross connectors are used acc. to EN 60079-0 and EN 60079-7 the current must be reduced to 4 A/40 K or 5 A/45 K for type WKFN 10/35.

Duo ground blocks with tension spring connection

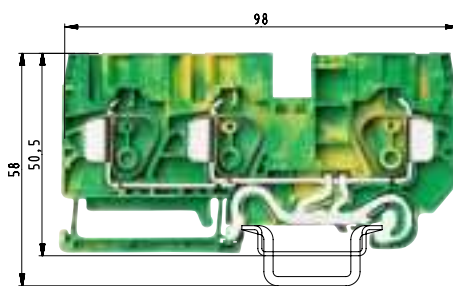
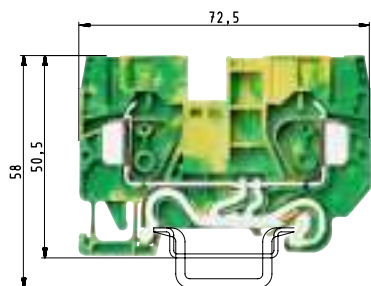

WKFN 10 SL/35

fine-stranded solid/stranded V A
 0.2–10 mm² 1.5–16 mm² 800 V/8 kV/3²⁾
 No. 16-6 AWG 600 V
 No. 16-6 AWG 600 V
 0.2–10 mm² 1.5–16 mm²
 10 mm 15 mm



WKFN 10 D1/2/SL/35

fine-stranded solid/stranded V A
 0.2–10 mm² 1.5–16 mm² 800 V/8 kV/3²⁾
 No. 16-6 AWG 600 V
 0.2–10 mm² 1.5–16 mm²
 10 mm 15 mm



Type	Part No.	Std. Pack	Type	Part No.	Std. Pack
WKFN 10 SL/35	56.710.9055.0	50	WKFN 10 D1/2/SL/35	56.710.9355.0	50
35x27x7,5 EN 60715	98.300.0000.0	1	35x27x7,5 EN 60715	98.300.0000.0	1
35x24x15 EN 60715	98.360.0000.0	1	35x24x15 EN 60715	98.360.0000.0	1
9708/2 S35	Z5.522.8553.0	100	9708/2 S35	Z5.522.8553.0	100
WEF 1/35	Z5.523.9353.0	100	WEF 1/35	Z5.523.9353.0	100
APFN 10 GRÜN	07.313.0855.7	10	APFN 10 D1/2 GRÜN	07.313.1055.7	10
IVB WKF 10-2	Z7.283.8227.0	10	IVB WKF 10-2	Z7.283.8227.0	10
ADF 10/4 GELB	04.343.6453.8	10	ADF 10/4 GELB	04.343.6453.8	10
ST 2/2,3	Z5.553.2921.0	10	ST 2/2,3	Z5.553.2921.0	10
DIN 5264 B 1x5,5	06.502.4200.0	5	DIN 5264 B 1x5,5	06.502.4200.0	5

Duo feed-through blocks with tension spring connection

fasis

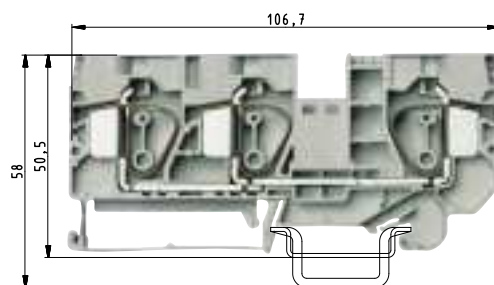
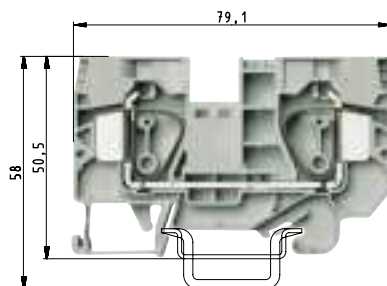

0344 Ex II 2GD IM2

Ex e I/II

EN 60 947-7-1:2002

UL ratings field/factory wiring

CSA ratings

PTB 06 ATEX 1075 U¹⁾ EN 60 079-0/EN 60 079-7

Width Wire strip length

Approvals

WKFN 16/35

fine-stranded	solid/stranded	V	A
0.2–16 mm ²	1.5–25 mm ²	800 V/8 kV/3	76
No. 16-4 AWG		600 V	85
No. 16-4 AWG		600 V	85
0.2–16 mm ²	1.5–25 mm ²	550 V	74/76*
12 mm			16 mm



WKFN 16 D1/2/35

fine-stranded	solid/stranded	V	A
0.2–16 mm ²	1.5–25 mm ²	800 V/8 kV/3	76
No. 16-4 AWG		600 V	85
No. 16-4 AWG		600 V	85
0.2–16 mm ²	1.5–25 mm ²	550 V	74/76*
12 mm			16 mm



	Type	Part No.	Std. Pack	Type	Part No.	Std. Pack
Feed-through block gray	WKFN 16/35	56.716.0055.0	50	WKFN 16 D1/2/35	56.716.5055.0	50
Feed-through block blue	WKFN 16/35 BLAU	56.716.0055.6	50	WKFN 16 D1/2/35 BLAU	56.716.5055.6	50
Ground block green/yellow						
Accessories						
1. Mounting rail 35, 7.5 mm high L = 2 m	35x27x7.5 EN 60715	98.300.0000.0	1	35x27x7.5 EN 60715	98.300.0000.0	1
Mounting rail 35, 15 mm high L = 2 m	35x24x15 EN 60715	98.360.0000.0	1	35x24x15 EN 60715	98.360.0000.0	1
2. End clamp TS 35, with screw 8 mm wide	9708/2 S35	Z5.522.8553.0	100	9708/2 S35	Z5.522.8553.0	100
End clamp TS 35, without screw 8 mm wide	WEF 1/35	Z5.523.9353.0	100	WEF 1/35	Z5.523.9353.0	100
3. End plate gray	APFN 16	07.313.1255.0	10	APFN 16 D1/2	07.313.1455.0	10
blue	APFN 16 BLAU	07.313.1255.6	10	APFN 16 D1/2 BLAU	07.313.1455.6	10
green						
4. Partition plate gray	TWFN 16	07.313.1355.0	10	TWFN 16 D1/2	07.313.1555.0	10
blue	TWFN 16 BLAU	07.313.1355.6	10	TWFN 16 D1/2 BLAU	07.313.1555.6	10
5. Cross connector** 2 pole	IVB WKF 16–2	Z7.284.4227.0	10	IVB WKF 16–2	Z7.284.4227.0	10
insulated 3 pole						
4 pole						
5 pole						
6 pole						
7 pole						
8 pole						
9 pole						
10 pole						
6. Reducing jumper, WKFN 35 to WKFN 10						
Reducing jumper, WKFN 35 to WKFN 16	IVB WKFN 35R16	Z7.285.6527.0	10	IVB WKFN 35R16	Z7.285.6527.0	10
Reducing jumper, WKFN 16 to WKFN 10	IVB WKFN 16R10	Z7.284.4327.0	10	IVB WKFN 16R10	Z7.284.4327.0	10
7. Cover with warning symbol for 4 terminals	ADF 16/4 GELB	04.343.6653.8	10	ADF 16/4 GELB	04.343.6653.8	10
8. Test adapter modular						
9. Test plug	ST 2/2,3	Z5.553.2921.0	10	ST 2/2,3	Z5.553.2921.0	10
10. Screwdriver, uninsulated	DIN 5264 B 1x5,5	06.502.4200.0	5	DIN 5264 B 1x5,5	06.502.4200.0	5
Marking accessories see page 76–79						

¹⁾ Follow the Ex installation instructions on the cover page
* 1. value at 40 K/2. value at 45 K

²⁾ For the current-carrying capabilities of the mounting rails see AT catalog section **facts & DATA**.

** When cross connectors are used according to EN 60079-0 and EN 60079-7, the current must be reduced to max. 3.5 A.

Duo ground blocks with tension spring connection

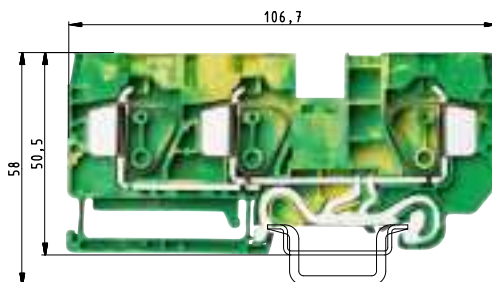
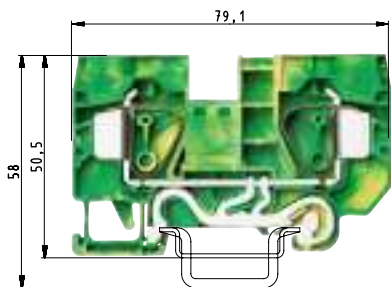

WKFN 16 SL/35

fine-stranded solid/stranded V A
 0.2–16 mm² 1.5–25 mm² 800 V/8 kV/3²⁾
 No. 16-4 AWG 600 V
 No. 16-4 AWG 600 V
 0.2–16 mm² 1.5–25 mm²
 12 mm 16 mm



WKFN 16 D1/2/SL/35

fine-stranded solid/stranded V A
 0.2–16 mm² 1.5–25 mm² 800 V/8 kV/3²⁾
 No. 16-4 AWG 600 V
 0.2–16 mm² 1.5–25 mm²
 12 mm 16 mm



Type	Part No.	Std. Pack	Type	Part No.	Std. Pack
WKFN 16 SL/35	56.716.9055.0	50	WKFN 16 D1/2/SL/35	56.716.9355.0	50
35x27x7,5 EN 60715	98.300.0000.0	1	35x27x7,5 EN 60715	98.300.0000.0	1
35x24x15 EN 60715	98.360.0000.0	1	35x24x15 EN 60715	98.360.0000.0	1
9708/2 S35	Z5.522.8553.0	100	9708/2 S35	Z5.522.8553.0	100
WEF 1/35	Z5.523.9353.0	100	WEF 1/35	Z5.523.9353.0	100
APFN 16 GRÜN	07.313.1255.7	10	APFN 16 D1/2 GRÜN	07.313.1455.7	10
IVB WKF 16-2	Z7.284.4227.0	10	IVB WKF 16-2	Z7.284.4227.0	10
ADF 16/4 GELB	04.343.6653.8	10	ADF 16/4 GELB	04.343.6653.8	10
ST 2/2,3	Z5.553.2921.0	10	ST 2/2,3	Z5.553.2921.0	10
DIN 5264 B 1x5,5	06.502.4200.0	5	DIN 5264 B 1x5,5	06.502.4200.0	5

Duo feed-through block/ground block with tension spring connection

fasis STS

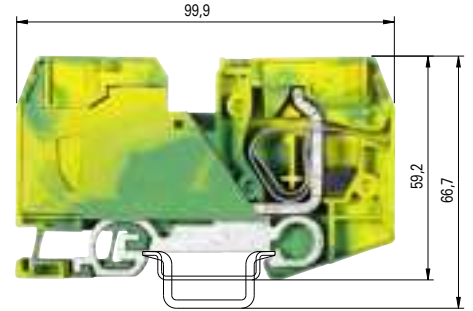
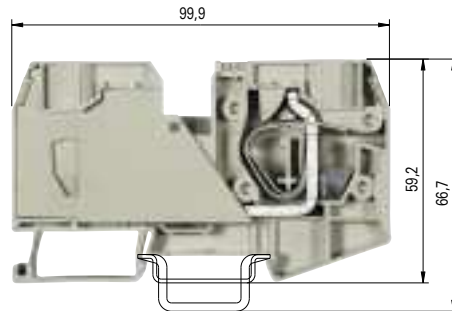

0344 Ex II 2GD

Ex e II

EN 60 947-7-1:2002

UL ratings

field/factory wiring

CSA ratings

KEMA 03 ATEX 2057 U¹⁾ EN 60 079-0/EN 60 079-3

Width

Wire strip length

Approvals

WKF 35/35

fine-stranded	solid/stranded	V	A
2.5–35 mm ²	2.5–35 mm ²	800 V/8 kV/3	125
No. 12-2 AWG		600 V	120
No. 12-2 AWG		600 V	120
2.5–35 mm ²	2.5–35 mm ²	690 V	92/108 ⁵⁾
16 mm			18 mm

ATEX

WKF 35 SL/35

fine-stranded	solid/stranded	V	A
2.5–35 mm ²	2.5–35 mm ²	800 V/8 kV/3 ⁴⁾	3 ³⁾
No. 12-2 AWG		600 V	
No. 12-2 AWG		600 V	
2.5–35 mm ²	2.5–35 mm ²		
16 mm			18 mm

ATEX

		Type	Part No.	Std. Pack	Type	Part No.	Std. Pack
Feed-through block	gray	WKF 35/35	56.735.0053.0	10			
Feed-through block	blue	WKF 35/35 BLAU	56.735.0053.6	10			
Ground block	green/yellow				WKF 35 SL/35	56.735.9053.0	10
Accessories							
1. Mounting rail 35, 7.5 mm high	L = 2 m	35x27x7,5 EN 60715	98.300.0000.0	1	35x27x7,5 EN 60715	98.300.0000.0	1
Mounting rail 35, 15 mm high	L = 2 m	35x24x15 EN 60715	98.360.0000.0	1	35x24x15 EN 60715	98.360.0000.0	1
2. End clamp TS 35, with screw ²⁾	8 mm wide	9708/2 S35	Z5.522.8553.0	100	9708/2 S35	Z5.522.8553.0	100
End clamp TS 35, without screw	8 mm wide						
3. End plate	gray						
	blue						
	green						
4. Partition plate	gray						
	blue						
5. Cross connector	2 pole	IVB WKF 35–2	Z7.285.6227.0	10	IVB WKF 35–2	Z7.285.6227.0	10
insulated	3 pole						
	4 pole						
	5 pole						
	6 pole						
	7 pole						
	8 pole						
	9 pole						
	10 pole						
6. Reducing jumper, WKF 35 to WKF 10 ⁶⁾		IVB WKF 35R10	Z7.285.6427.0	10			
Reducing jumper, WKF 35 to WKF 16 ⁶⁾		IVB WKF 35R16	Z7.285.6527.0	10			
Reducing jumper, WKF 16 to WKF 10 ⁶⁾		IVB WKF 16R10	Z7.284.4327.0	10			
7. Cover with warning symbol for 4 terminals		ADF 35/5 GELB	04.343.9253.8	10	ADF 35/5 GELB	04.343.9253.8	10
8. Test adapter modular							
9. Test plug		ST 2/2,3	Z5.553.2921.0	10	ST 2/2,3	Z5.553.2921.0	10
10. Screwdriver, uninsulated		DIN 5264 B 1x5,5	06.502.4200.0	5	DIN 5264 B 1x5,5	06.502.4200.0	5
Marking accessories see page 76–79							

¹⁾ Follow the Ex installation instructions on the cover page

²⁾ Do not use in Ex environments.

³⁾ For the current-carrying capabilities of the mounting rails see AT catalog section **facts & DATA**. ⁴⁾ Ratings to adjacent feed-through blocks of the same series and size ⁵⁾ with/without jumper

⁶⁾ When cross connectors are used acc. to EN 60079-0 and EN 60079-7 the current must be reduced (values to be requested)

Potential supply with feed-through blocks up to 35 mm²

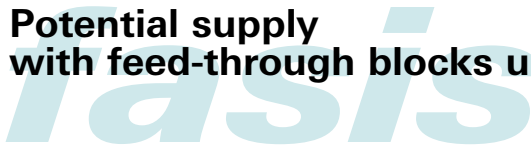

$I_{\max E}$: I_{\max} supply
 $I_{\max R}$: I_{\max} reducing cross connector
 I_{N-A} : I_N output terminal block

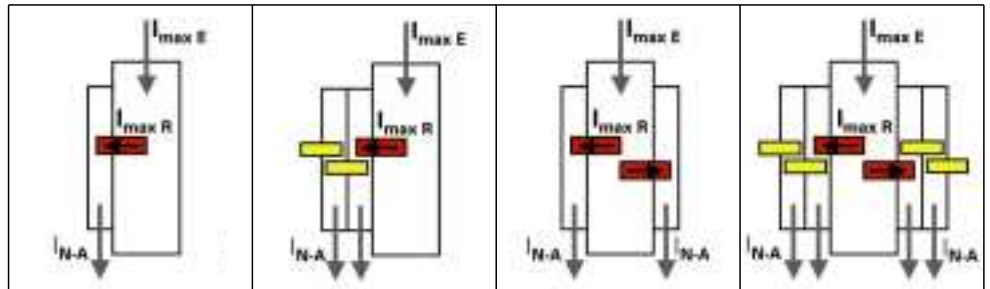

Potential distribution	Distribution on one side		Distribution on both sides	
	2 poles	several poles	2 poles	several poles
35-R-10	I_{\max} supply	125 A	125 A	125 A
	I_{\max} reducing cross connector	57 A	105 A	57 A
	I_N output terminal block	57 A	57 A	57 A
35-R-16	I_{\max} supply	125 A	125 A	125 A
	I_{\max} reducing cross connector	76 A	105 A	76 A
	I_N output terminal block	76 A	76 A	76 A
16-R-10	I_{\max} supply	76 A	76 A	-
	I_{\max} reducing cross connector	57 A	76 A	-
	I_N output terminal block	57 A	57 A	-

	Type	Part No.	Std. Pack	Type	Part No.	Std. Pack
Potential distribution 35 R 10	Supply block			WKF 35 /35	56.735.0035.0	10
	Supply block			WKF 35 /35 BLAU	56.735.0035.6	10
Potential supply 35 mm ²	Reducing cross connector			IVB WKFN 35R10	Z7.285.6427.0	10
Reducing cross connector 35R10						
Potential output 10 mm ²	Output block			WKFN 10 /35	56.710.0055.0	10
	Output block			WKFN 10 /35 BLAU	56.710.0055.6	10
	Output block			WKFN 10 D1/2/35	56.710.5055.0	10
	Output block			WKFN 10 D1/2/35 BLAU	56.710.5055.6	10
Potential distribution 35 R 16	Supply block			WKF 35 /35	56.735.0035.0	10
	Supply block			WKF 35 /35 BLAU	56.735.0035.6	10
Potential supply 35 mm ²	Reducing cross connector			IVB WKFN 35R16	Z7.285.6527.0	10
Reducing cross connector 35R16						
Potential output 16 mm ²	Output block			WKFN 16 /35	56.716.0055.0	10
	Output block			WKFN 16 /35 BLAU	56.716.0055.6	10
	Output block			WKFN 16 D1/2/35	56.716.5055.0	10
	Output block			WKFN 16 D1/2/35 BLAU	56.716.5055.6	10
Potential distribution 16 R 10	Supply block			WKFN 16 /35	56.716.0055.0	10
	Supply block			WKFN 16 /35 BLAU	56.716.0055.6	10
Supply block			WKFN 16 D1/2/35	56.716.5055.0	10	
Potential supply 16 mm ²	Supply block			WKFN 16 D1/2/35 BLAU	56.716.5055.6	10
Reducing cross connector 16R10						
Potential output 10 mm ²	Reducing cross connector			IVB WKFN 35R16	Z7.285.6527.0	10
	Output block			WKFN 16 /35	56.716.0055.0	10
	Output block			WKFN 16 /35 BLAU	56.716.0055.6	10
	Output block			WKFN 16 D1/2/35	56.716.5055.0	10
	Output block			WKFN 16 D1/2/35 BLAU	56.716.5055.6	10
	Output block			WKFN 16 D1/2/35 BLAU	56.716.5055.6	10

Multi-tier terminal blocks with tension spring connection

fasis

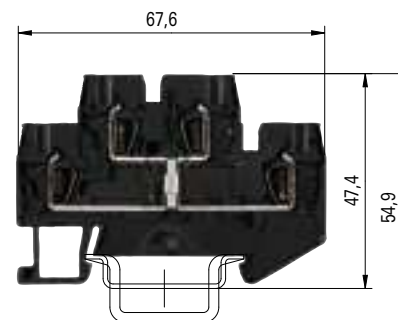
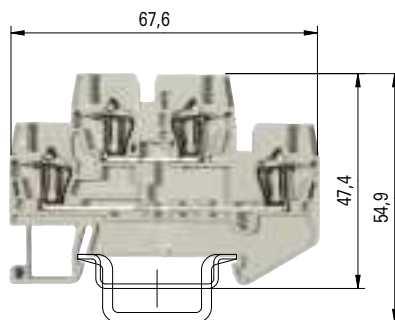

0344 Ex II 2GD

Ex e II

EN 60 947-7-1:2002

UL ratings field/factory wiring

CSA ratings

KEMA 03 ATEX 2056 U¹⁾ EN 60 079-0/EN 60 079-7

Width Wire strip length

Approvals

WKF 1,5 E2/35

fine-stranded solid V A
0.08–1,5 mm² 0.08–1.5 mm² 500 V/6 kV/3 17,5
No. 26-14 AWG 300 V 15
No. 26-14 AWG 300 V 15
0.14–1,5 mm² 0.14–1.5 mm² 440 V^{*)} 15/13,5³⁾
4 mm 10 mm

ATEX

WKF 1,5 E2/VB/35

fine-stranded solid V A
0.08–1,5 mm² 0.08–1.5 mm² 500 V/6 kV/3 17,5
No. 26-14 AWG 300 V 15
No. 26-14 AWG 300 V 15
0.14–1,5 mm² 0.14–1.5 mm² 440 V^{*)} 15/13,5³⁾
4 mm 10 mm

ATEX

	Type	Part No.	Std. Pack	Type	Part No.	Std. Pack
Multi-tier block gray	WKF 1,5 E2/35	56.702.7653.0	50			
Multi-tier block, vertically connected black				WKF 1,5 E2/VB/35	56.702.6953.1	50
Multi-tier block, combined gray						
Multi-tier ground block green/yellow						
Accessories						
1. Mounting rail 35, 7.5 mm high L = 2 m	35x27x7,5 EN 60715	98.300.0000.0	1	35x27x7,5 EN 60715	98.300.0000.0	1
Mounting rail 35, 15 mm high L = 2 m	35x24x15 EN 60715	98.360.0000.0	1	35x24x15 EN 60715	98.360.0000.0	1
2. End clamp TS 35, with screw ²⁾ 8 mm wide	9708/2 S35	Z5.522.8553.0	100	9708/2 S35	Z5.522.8553.0	100
End clamp TS 35, without screw 8 mm wide	WEF 1/35	Z5.523.9353.0	100	WEF 1/35	Z5.523.9353.0	100
3. End plate gray	APF 1,5 E2	07.312.8753.0	10	APF 1,5 E2	07.312.8753.0	10
blue						
Segment end plate gray						
4. Partition plate gray	TWF 1,5 E2	07.312.8853.0	10	TWF 1,5 E2	07.312.8853.0	10
blue						
5. Cross connector 2 pole	IVB WKF 1,5–2	Z7.268.0227.0	10	IVB WKF 1,5–2	Z7.268.0227.0	10
insulated 3 pole	IVB WKF 1,5–3	Z7.268.0327.0	10	IVB WKF 1,5–3	Z7.268.0327.0	10
4 pole	IVB WKF 1,5–4	Z7.268.0427.0	10	IVB WKF 1,5–4	Z7.268.0427.0	10
5 pole	IVB WKF 1,5–5	Z7.268.0527.0	10	IVB WKF 1,5–5	Z7.268.0527.0	10
10 pole	IVB WKF 1,5–10	Z7.268.1027.0	10	IVB WKF 1,5–10	Z7.268.1027.0	10
20 pole	IVB WKF 1,5–20	Z7.268.2027.0	10	IVB WKF 1,5–20	Z7.268.2027.0	10
6. Wire entry guide 0.13–0.2 mm ²	LEL 1,5/1 WEISS	05.564.4253.0	10	LEL 1,5/1 WEISS	05.564.4253.0	10
0.25–0.5 mm ²	LEL 1,5/2 GRAU	05.564.4353.0	10	LEL 1,5/2 GRAU	05.564.4353.0	10
0.75–1.0 mm ²						
7. Cover with warning symbol over 5 blocks	ADF 1,5/5 GELB	04.343.6953.8	10	ADF 1,5/5 GELB	04.343.6953.8	10
8. Marking tag carrier, 2-fold	BT 4/2	04.243.0953.0	100	BT 4/2	04.243.0953.0	100
9. Test adapter, modular						
10. Test plug						
11. Screwdriver, uninsulated	DIN 5264 B 0,4x2,5	06.502.4300.0	5	DIN 5264 B 0,4x2,5	06.502.4300.0	5
Marking accessories see page 76–79						

^{*)} For maintaining the proper isolation distances, the open side of a feed-through terminal block as well as both sides of a jumper are to be covered by partitions.

¹⁾ Follow the Ex installation instructions on the cover page

²⁾ Do not use in Ex environments.

³⁾ Rated current when using cross connectors

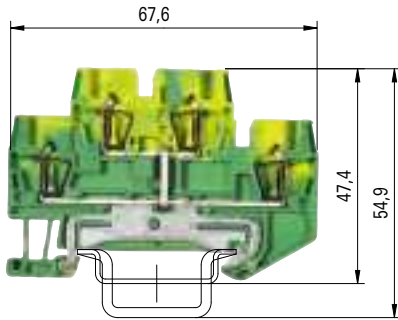

WKF 1,5 E2/SL/35

fine-stranded solid V A
 0.08–1.5 mm² 0.08–1.5 mm² 500 V/6 kV/3
 No. 26-14 AWG 300 V
 No. 26-14 AWG 300 V
 0.14–1.5 mm² 0.14–1.5 mm² *)
 4 mm 10 mm
 ATEX

Type	Part No.	Std. Pack
WKF 1,5 E2/SL/35	56.702.9253.0	50
35x27x7,5 EN 60715	98.300.0000.0	1
35x24x15 EN 60715	98.360.0000.0	1
9708/2 S35	Z5.522.8553.0	100
WEF 1/35	Z5.523.9353.0	100
APF 1,5 E2	07.312.8753.0	10
TWF 1,5 E2	07.312.8853.0	10
IVB WKF 1,5–2	Z7.268.0227.0	10
IVB WKF 1,5–3	Z7.268.0327.0	10
IVB WKF 1,5–4	Z7.268.0427.0	10
IVB WKF 1,5–5	Z7.268.0527.0	10
IVB WKF 1,5–10	Z7.268.1027.0	10
IVB WKF 1,5–20	Z7.268.2027.0	10
LEL 1,5/1 WEISS	05.564.4253.0	10
LEL 1,5/2 GRAU	05.564.4353.0	10
ADF 1,5/5 GELB	04.343.6953.8	10
BT 4/2	04.243.0953.0	100
DIN 5264 B 0,4x2,5	06.502.4300.0	5

Multi-tier terminal blocks with tension spring connection

fasis

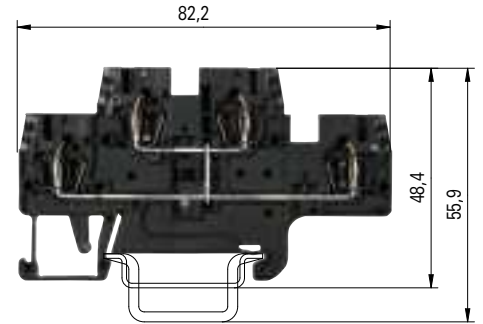
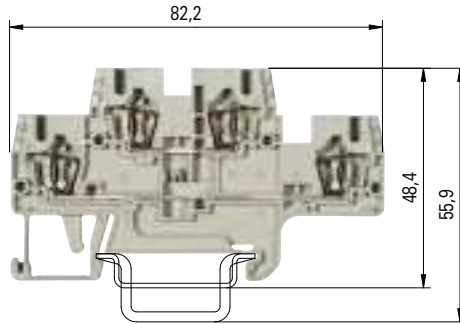

0344 Ex II 2GD IM2

Ex e I/II

EN 60 947-7-1:2002

UL ratings field/factory wiring

CSA ratings

PTB 04 ATEX 1051 U¹⁾ EN 60 079-0/EN 60 079-7

Width Wire strip length

Approvals

WKFN 2,5 E/35

WKFN 2,5 E/N/D/35

	V	A
fine-stranded solid		
0.13–2.5 mm ² 0.13–4 mm ²	500 V/6 kV/3	24
No. 22-12 AWG	300 V	20
No. 24-12 AWG	300 V	24
0.2–2.5 mm ² 0.13–4 mm ²	440/275* 20/21.5 ²⁾	
5 mm		11 mm

PTB

WKFN 2,5 E/VB/35

	V	A
fine-stranded solid		
0.13–2.5 mm ² 0.13–4 mm ²	500 V/6 kV/3	24
No. 22-12 AWG	600 V	20
No. 24-12 AWG	600 V	24
0.2–2.5 mm ² 0.13–4 mm ²	440 20/21.5 ²⁾	
5 mm		11 mm

PTB

		Type	Part No.	Std. Pack	Type	Part No.	Std. Pack
Multi-tier block	gray	WKFN 2,5 E/35	56.703.7055.0	100			
Multi-tier block, vertically connected	black				WKFN 2,5 E/VB/35	56.703.6955.1	100
Multi-tier block, combined	gray	WKFN 2,5 E/N/D/35	56.703.7655.0	100			
Multi-tier block, combined	gray						
Multi-tier ground block	green/yellow						
Accessories							
1. Mounting rail 35, 7.5 mm high	L = 2 m	35x27x7,5 EN 60715	98.300.0000.0	1	35x27x7,5 EN 60715	98.300.0000.0	1
Mounting rail 35, 15 mm high	L = 2 m	35x24x15 EN 60715	98.360.0000.0	1	35x24x15 EN 60715	98.360.0000.0	1
2. End clamp TS 35, with screw	8 mm wide	9708/2 S35	Z5.522.8553.0	100	9708/2 S35	Z5.522.8553.0	100
End clamp TS 35, without screw	8 mm wide	WEF 1/35	Z5.523.9353.0	100	WEF 1/35	Z5.523.9353.0	100
3. End plate	gray	APFN 2,5 E	07.312.7355.0	10	APFN 2,5 E	07.312.7355.0	10
	blue						
	green						
4. Partition plate	gray	TWFN 2,5 E	07.312.7455.0	10	TWFN 2,5 E	07.312.7455.0	10
	blue						
5. Cross connector	2 pole	IVB WKF 2,5–2	Z7.280.6227.0	10	IVB WKF 2,5–2	Z7.280.6227.0	10
insulated	3 pole	IVB WKF 2,5–3	Z7.280.6327.0	10	IVB WKF 2,5–3	Z7.280.6327.0	10
	4 pole	IVB WKF 2,5–4	Z7.280.6427.0	10	IVB WKF 2,5–4	Z7.280.6427.0	10
	5 pole	IVB WKF 2,5–5	Z7.280.6527.0	10	IVB WKF 2,5–5	Z7.280.6527.0	10
	until 10 pole	IVB WKF 2,5–10	Z7.280.7027.0	20	IVB WKF 2,5–10	Z7.280.7027.0	20
Vertical cross connector	1 pole	IVB WKF–V	Z7.261.1127.0	10	IVB WKF–V	Z7.261.1127.0	10
6. Wire entry guide	0.13–0.2 mm ²	LELN 2,5/1 WEISS	05.564.3755.0	100	LELN 2,5/1 WEISS	05.564.3755.0	100
	0.25–0.5 mm ²	LELN 2,5/2 GRAU	05.564.3855.0	100	LELN 2,5/2 GRAU	05.564.3855.0	100
	0.75–1.0 mm ²	LELN 2,5/3 SCHWARZ	05.564.3955.0	100	LELN 2,5/3 SCHWARZ	05.564.3955.0	100
7. Cover with warning symbol over 4 blocks		ADFN 2,5/4 GELB	04.343.8353.8	10	ADFN 2,5/4 GELB	04.343.8353.8	10
8. Marking tag carrier, 2-fold		BT 5/2	04.243.0855.0	100	BT 5/2	04.243.0855.0	100
9. Test adapter, modular		PS WKC/F	Z1.299.9753.0	10	PS WKC/F	Z1.299.9753.0	10
10. Test plug		ST 2/2,3	Z5.553.2921.0	10	ST 2/2,3	Z5.553.2921.0	10
11. Screwdriver, uninsulated		DIN 5264 B 0,6x3,5	06.502.4000.0	5	DIN 5264 B 0,6x3,5	06.502.4000.0	5
Screwdriver, uninsulated, MINI		DIN 5264 B 0,6x3,5 M	06.502.5000.0	10	DIN 5264 B 0,6x3,5 M	06.502.5000.0	10
Marking accessories see page 76–79							

¹⁾ Follow the Ex installation instructions on the cover page

²⁾ 1. value at 40 K/2. value at 45 K

* When using cross connectors on the upper tier

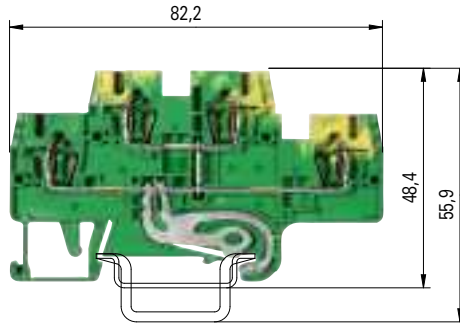
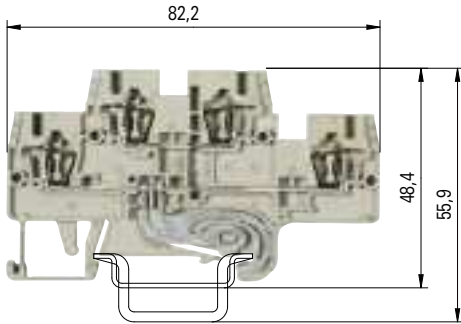

WKFN 2,5 E/D/SL/35 WKFN 2,5 E/N/SL/35

fine-stranded solid V A
 0.13–2.5 mm² 0.13–4 mm² 500 V/6 kV/3 24
 No. 22-12 AWG 300 V 20
 No. 24-12 AWG 300 V 24

5 mm 11 mm



WKFN 2,5 E/SL/35

fine-stranded solid V A
 0.13–2.5 mm² 0.13–4 mm² 500 V/6 kV/3
 No. 22-12 AWG 600 V
 No. 24-12 AWG 600 V
 0.2–2.5 mm² 0.13–4 mm²

5 mm 11 mm



Type	Part No.	Std. Pack	Type	Part No.	Std. Pack
WKFN 2,5 E/D/SL/35	56.703.7855.0	100			
WKFN 2,5 E/N/SL/35	56.703.7755.0	100			
			WKFN 2,5 E/SL/35	56.703.8955.0	100
35x27x7,5 EN 60715	98.300.0000.0	1	35x27x7,5 EN 60715	98.300.0000.0	1
35x24x15 EN 60715	98.360.0000.0	1	35x24x15 EN 60715	98.360.0000.0	1
9708/2 S35	Z5.522.8553.0	100	9708/2 S35	Z5.522.8553.0	100
WEF 1/35	Z5.523.9353.0	100	WEF 1/35	Z5.523.9353.0	100
APFN 2,5 E	07.312.7355.0	10			
			APFN 2,5 E GRÜN	07.312.7355.7	10
TWFN 2,5 E	07.312.7455.0	10			
IVB WKF 2,5–2	Z7.280.6227.0	10			
IVB WKF 2,5–3	Z7.280.6327.0	10			
IVB WKF 2,5–4	Z7.280.6427.0	10			
IVB WKF 2,5–5	Z7.280.6527.0	10			
IVB WKF 2,5–10	Z7.280.7027.0	20			
IVB WKF–V	Z7.261.1127.0	10			
LELN 2,5/1 WEISS	05.564.3755.0	100	LELN 2,5/1 WEISS	05.564.3755.0	100
LELN 2,5/2 GRAU	05.564.3855.0	100	LELN 2,5/2 GRAU	05.564.3855.0	100
LELN 2,5/3 SCHWARZ	05.564.3955.0	100	LELN 2,5/3 SCHWARZ	05.564.3955.0	100
ADFN 2,5/4 GELB	04.343.8353.8	10	ADFN 2,5/4 GELB	04.343.8353.8	10
BT 5/2	04.243.0855.0	100	BT 5/2	04.243.0855.0	100
PS WKC/F	Z1.299.9753.0	10	PS WKC/F	Z1.299.9753.0	10
ST 2/2,3	Z5.553.2921.0	10	ST 2/2,3	Z5.553.2921.0	10
DIN 5264 B 0,6x3,5	06.502.4000.0	5	DIN 5264 B 0,6x3,5	06.502.4000.0	5
DIN 5264 B 0,6x3,5 M	06.502.5000.0	10	DIN 5264 B 0,6x3,5 M	06.502.5000.0	10

WKFN 2,5 E/35

Block color: gray

	Function	Color ID
Upper tier	Feed-through	gray
Lower tier	Feed-through	gray

WKFN 2,5 E/N/D/35

Block color: gray

	Function	Color ID
Upper tier	Feed-through	blue
Lower tier	Feed-through	gray

WKFN 2,5 E/VB/35

Block color: gray

	Function	Color ID
Upper tier	Feed-through	black
Lower tier	vertically jumpered	black

WKFN 2,5 E/D/SL/35

Block color: gray

	Function	Color ID
Upper tier	Feed-through	gray
Lower tier	Ground conductor	green/yellow

WKFN 2,5 E/N/SL/35

Block color: gray

	Function	Color ID
Upper tier	Feed-through	blue
Lower tier	Ground conductor	green/yellow

WKFN 2,5 E/SL/35

Block color: green/yellow

	Function	Color ID
Upper tier	Ground conductor	green/yellow
Lower tier	vertically jumpered	green/yellow

Duo multi-tier terminal blocks with tension spring connection

fasis

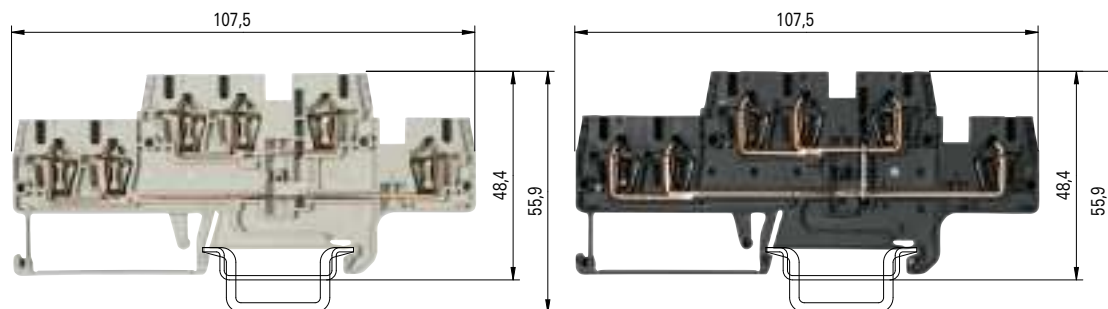

0344 Ex II 2GD IM2

Ex e I/II

EN 60 947-7-1:2002

UL ratings

field/factory wiring

CSA ratings

PTB 04 ATEX 1051 U¹⁾ EN 60 079-0/EN 60 079-7

Width

Wire strip length

Approvals

WKFN 2,5 E1/2/35

WKFN 2,5 E1/2/N/D/35

fine-stranded solid		V	A
0.13–2.5 mm ²	0.13–4 mm ²	500 V/6 kV/3	22
No. 22-12 AWG		300 V	20
No. 24-12 AWG		300 V	24
0.2–2.5 mm ²	0.13–4 mm ²	440/275*	20/21 ²⁾
5 mm			11 mm

PTB

WKFN 2,5 E1/2/VB/35

fine-stranded solid		V	A
0.13–2.5 mm ²	0.13–4 mm ²	500 V/6 kV/3	22
No. 22-12 AWG		600 V	20
No. 24-12 AWG		600 V	24
0.2–2.5 mm ²	0.13–4 mm ²	440	20/21 ²⁾
5 mm			11 mm

PTB

		Type	Part No.	Std. Pack	Type	Part No.	Std. Pack
Multi-tier block	gray	WKFN 2,5 E1/2/35	56.703.6055.0	50			
Multi-tier block, vertically connected	black				WKFN 2,5 E1/2/VB/35	56.703.5955.1	50
Multi-tier block, combined	gray	WKFN 2,5 E1/2/N/D/35	56.703.6355.0	50			
Multi-tier block, combined	gray						
Multi-tier ground block	green/yellow						
Accessories							
1. Mounting rail 35, 7.5 mm high	L = 2 m	35x27x7,5 EN 60715	98.300.0000.0	1	35x27x7,5 EN 60715	98.300.0000.0	1
Mounting rail 35, 15 mm high	L = 2 m	35x24x15 EN 60715	98.360.0000.0	1	35x24x15 EN 60715	98.360.0000.0	1
2. End clamp TS 35, with screw	8 mm wide	9708/2 S35	Z5.522.8553.0	100	9708/2 S35	Z5.522.8553.0	100
End clamp TS 35, without screw	8 mm wide	WEF 1/35	Z5.523.9353.0	100	WEF 1/35	Z5.523.9353.0	100
3. End plate	gray	APFN 2,5 E1/2	07.312.7755.0	10	APFN 2,5 E1/2	07.312.7755.0	10
	blue						
	green						
4. Partition plate	gray	TWFN 2,5 E1/2	07.312.7855.0	10	TWFN 2,5 E1/2	07.312.7855.0	10
	blue						
5. Cross connector	2 pole	IVB WKF 2,5–2	Z7.280.6227.0	10	IVB WKF 2,5–2	Z7.280.6227.0	10
insulated	3 pole	IVB WKF 2,5–3	Z7.280.6327.0	10	IVB WKF 2,5–3	Z7.280.6327.0	10
	4 pole	IVB WKF 2,5–4	Z7.280.6427.0	10	IVB WKF 2,5–4	Z7.280.6427.0	10
	5 pole	IVB WKF 2,5–5	Z7.280.6527.0	10	IVB WKF 2,5–5	Z7.280.6527.0	10
	until 10 pole	IVB WKF 2,5–10	Z7.280.7027.0	20	IVB WKF 2,5–10	Z7.280.7027.0	20
Vertical cross connector	1 pole	IVB WKF–V	Z7.261.1127.0	10	IVB WKF–V	Z7.261.1127.0	10
6. Wire entry guide	0.13–0.2 mm ²	LELN 2,5/1 WEISS	05.564.3755.0	100	LELN 2,5/1 WEISS	05.564.3755.0	100
	0.25–0.5 mm ²	LELN 2,5/2 GRAU	05.564.3855.0	100	LELN 2,5/2 GRAU	05.564.3855.0	100
	0.75–1.0 mm ²	LELN 2,5/3 SCHWARZ	05.564.3955.0	100	LELN 2,5/3 SCHWARZ	05.564.3955.0	100
7. Cover with warning symbol over 4 blocks		ADFN 2,5/4 GELB	04.343.8353.8	10	ADFN 2,5/4 GELB	04.343.8353.8	10
8. Marking tag carrier, 2-fold		BT 5/2	04.243.0855.0	100	BT 5/2	04.243.0855.0	100
9. Test adapter, modular		PS WKC/F	Z1.299.9753.0	10	PS WKC/F	Z1.299.9753.0	10
10. Test plug		ST 2/2,3	Z5.553.2921.0	10	ST 2/2,3	Z5.553.2921.0	10
11. Screwdriver, uninsulated		DIN 5264 B 0,6x3,5	06.502.4000.0	5	DIN 5264 B 0,6x3,5	06.502.4000.0	5
Screwdriver, uninsulated, MINI		DIN 5264 B 0,6x3,5 M	06.502.5000.0	10	DIN 5264 B 0,6x3,5 M	06.502.5000.0	10
Marking accessories see page 76–79							

¹⁾ Follow the Ex installation instructions on the cover page

²⁾ 1. value at 40 K/2. value at 45 K

* When using cross connectors on the upper tier

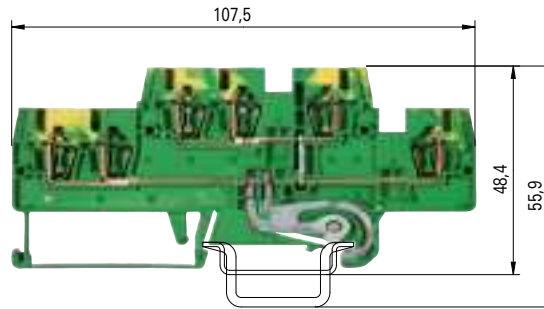
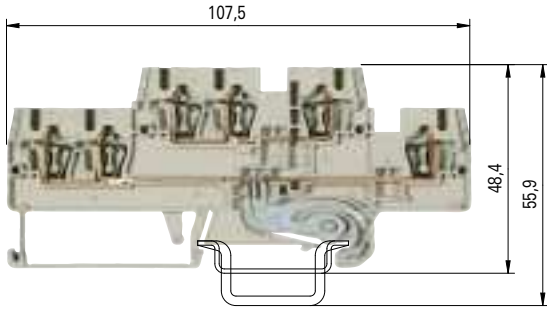

WKFN 2,5 E1/2/D/SL/35 WKFN 2,5 E1/2/N/SL/35

fine-stranded solid V A
0.13–2.5 mm² 0.13–4 mm² 500 V/6 kV/3 22
No. 22-12 AWG 300 V 20
No. 24-12 AWG 300 V 24

5 mm 11 mm



WKFN 2,5 E1/2/SL/35

fine-stranded solid V A
0.13–2.5 mm² 0.13–4 mm² 500 V/6 kV/3
No. 22-12 AWG 600 V
No. 24-12 AWG 600 V
0.2–2.5 mm² 0.13–4 mm²

5 mm 11 mm



Type	Part No.	Std. Pack	Type	Part No.	Std. Pack
WKFN 2,5 E1/2/D/SL/35	56.703.6155.0	50			
WKFN 2,5 E1/2/N/SL/35	56.703.6455.0	50			
			WKFN 2,5 E/SL/35	56.703.6255.0	50
35x27x7,5 EN 60715	98.300.0000.0	1	35x27x7,5 EN 60715	98.300.0000.0	1
35x24x15 EN 60715	98.360.0000.0	1	35x24x15 EN 60715	98.360.0000.0	1
9708/2 S35	Z5.522.8553.0	100	9708/2 S35	Z5.522.8553.0	100
WEF 1/35	Z5.523.9353.0	100	WEF 1/35	Z5.523.9353.0	100
APFN 2,5 E1/2	07.312.7755.0	10			
			APFN 2,5 E1/2 GRÜN	07.312.7755.7	10
TWFN 2,5 E1/2	07.312.7855.0	10			
IVB WKF 2,5–2	Z7.280.6227.0	10			
IVB WKF 2,5–3	Z7.280.6327.0	10			
IVB WKF 2,5–4	Z7.280.6427.0	10			
IVB WKF 2,5–5	Z7.280.6527.0	10			
IVB WKF 2,5–10	Z7.280.7027.0	20			
IVB WKF–V	Z7.261.1127.0	10			
LELN 2,5/1 WEISS	05.564.3755.0	100	LELN 2,5/1 WEISS	05.564.3755.0	100
LELN 2,5/2 GRAU	05.564.3855.0	100	LELN 2,5/2 GRAU	05.564.3855.0	100
LELN 2,5/3 SCHWARZ	05.564.3955.0	100	LELN 2,5/3 SCHWARZ	05.564.3955.0	100
ADFN 2,5/4 GELB	04.343.8353.8	10	ADFN 2,5/4 GELB	04.343.8353.8	10
BT 5/2	04.243.0855.0	100	BT 5/2	04.243.0855.0	100
PS WKC/F	Z1.299.9753.0	10	PS WKC/F	Z1.299.9753.0	10
ST 2/2,3	Z5.553.2921.0	10	ST 2/2,3	Z5.553.2921.0	10
DIN 5264 B 0,6x3,5	06.502.4000.0	5	DIN 5264 B 0,6x3,5	06.502.4000.0	5
DIN 5264 B 0,6x3,5 M	06.502.5000.0	10	DIN 5264 B 0,6x3,5 M	06.502.5000.0	10

WKFN 2,5 E1/2/35 Block color: gray

	Function	Color ID
Upper tier	Feed-through	gray
Lower tier	Feed-through	gray

WKFN 2,5 E1/2/N/D/35 Block color: gray

	Function	Color ID
Upper tier	Feed-through	blue
Lower tier	Feed-through	gray

WKFN 2,5 E1/2/VB/35 Block color: black

	Function	Color ID
Upper tier	Feed-through	black
Lower tier	vertically jumpered	black

WKFN 2,5 E1/2/D/SL/35 Block color: gray

	Function	Color ID
Upper tier	Feed-through	gray
Lower tier	Ground conductor	green/yellow

WKFN 2,5 E1/2/N/SL/35 Block color: gray

	Function	Color ID
Upper tier	Feed-through	blue
Lower tier	Ground conductor	green/yellow

WKFN 2,5 E1/2/SL/35 Block color: green/yellow

	Function	Color ID
Upper tier	Ground conductor	green/yellow
Lower tier	vertically jumpered	green/yellow

Multi-tier terminal blocks with tension spring connection

fasis

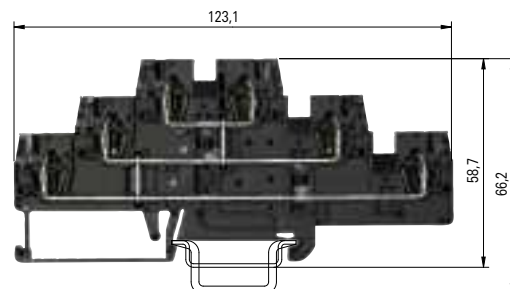
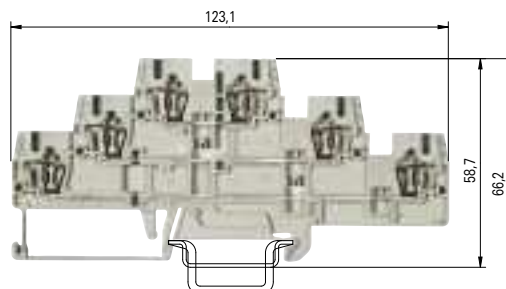

0344 Ex II 2GD IM2

Ex e I/II

EN 60 947-7-1:2002

UL ratings

field/factory wiring

CSA ratings

PTB 04 ATEX 1051 U1) EN 60 079-0/EN 60 079-7

Width

Wire strip length

Approvals

WKFN 2,5 E3/35

fine-stranded solid V A
 0.13–2.5 mm² 0.13–4 mm² 500 V/6 kV/3 20
 No. 22-12 AWG 300 V 20
 No. 24-12 AWG 300 V 24
 0.2–2.5 mm² 0.13–4 mm² 440/275* 19/20²⁾
 5 mm 11 mm

PTB

WKFN 2,5 E3/VB/35

fine-stranded solid V A
 0.13–2.5 mm² 0.13–4 mm² 500 V/6 kV/3 24
 No. 22-12 AWG 600 V 20
 No. 24-12 AWG 600 V 24
 0.2–2.5 mm² 0.13–4 mm² 440 20/21.5²⁾
 5 mm 11 mm

PTB

		Type	Part No.	Std. Pack	Type	Part No.	Std. Pack
Multi-tier block	gray	WKFN 2,5 E3/35	56.703.3055.0	50			
Multi-tier block, vertically connected	black				WKFN 2,5 E3/VB/35	56.703.2955.1	50
Multi-tier block, combined	gray						
Multi-tier block, combined	gray						
Multi-tier ground block	green/yellow						
Accessories							
1. Mounting rail 35, 7.5 mm high	L = 2 m	35x27x7,5 EN 60715	98.300.0000.0	1	35x27x7,5 EN 60715	98.300.0000.0	1
Mounting rail 35, 15 mm high	L = 2 m	35x24x15 EN 60715	98.360.0000.0	1	35x24x15 EN 60715	98.360.0000.0	1
2. End clamp TS 35, with screw	8 mm wide	9708/2 S35	Z5.522.8553.0	100	9708/2 S35	Z5.522.8553.0	100
End clamp TS 35, without screw	8 mm wide	WEF 1/35	Z5.523.9353.0	100	WEF 1/35	Z5.523.9353.0	100
3. End plate	gray	APFN 2,5 E3	07.312.7555.0	10	APFN 2,5 E3	07.312.7555.0	10
	blue						
	green						
4. Partition plate	gray	TWFN 2,5 E3	07.312.7655.0	10	TWFN 2,5 E3	07.312.7655.0	10
	blue						
5. Cross connector	2 pole	IVB WKF 2,5–2	Z7.280.6227.0	10	IVB WKF 2,5–2	Z7.280.6227.0	10
insulated	3 pole	IVB WKF 2,5–3	Z7.280.6327.0	10	IVB WKF 2,5–3	Z7.280.6327.0	10
	4 pole	IVB WKF 2,5–4	Z7.280.6427.0	10	IVB WKF 2,5–4	Z7.280.6427.0	10
	5 pole	IVB WKF 2,5–5	Z7.280.6527.0	10	IVB WKF 2,5–5	Z7.280.6527.0	10
	until 10 pole	IVB WKF 2,5–10	Z7.280.7027.0	20	IVB WKF 2,5–10	Z7.280.7027.0	20
Vertical cross connector	1 pole	IVB WKF–V	Z7.261.1127.0	10	IVB WKF–V	Z7.261.1127.0	10
6. Wire entry guide	0.13–0.2 mm ²	LELN 2,5/1 WEISS	05.564.3755.0	100	LELN 2,5/1 WEISS	05.564.3755.0	100
	0.25–0.5 mm ²	LELN 2,5/2 GRAU	05.564.3855.0	100	LELN 2,5/2 GRAU	05.564.3855.0	100
	0.75–1.0 mm ²	LELN 2,5/3 SCHWARZ	05.564.3955.0	100	LELN 2,5/3 SCHWARZ	05.564.3955.0	100
7. Cover with warning symbol over 4 blocks		ADFN 2,5/4 GELB	04.343.8353.8	10	ADFN 2,5/4 GELB	04.343.8353.8	10
8. Marking tag carrier, 2-fold		BT 5/3	04.243.0755.0	100	BT 5/3	04.243.0755.0	100
9. Test adapter, modular		PS WKC/F	Z1.299.9753.0	10	PS WKC/F	Z1.299.9753.0	10
10. Test plug		ST 2/2,3	Z5.553.2921.0	10	ST 2/2,3	Z5.553.2921.0	10
11. Screwdriver, uninsulated		DIN 5264 B 0,6x3,5	06.502.4000.0	5	DIN 5264 B 0,6x3,5	06.502.4000.0	5
Screwdriver, uninsulated, MINI		DIN 5264 B 0,6x3,5 M	06.502.5000.0	10	DIN 5264 B 0,6x3,5 M	06.502.5000.0	10
Marking accessories see page 76–79							

¹⁾ Follow the Ex installation instructions on the cover page

²⁾ 1. value at 40 K/2. value at 45 K

* When using cross connectors on the upper tier

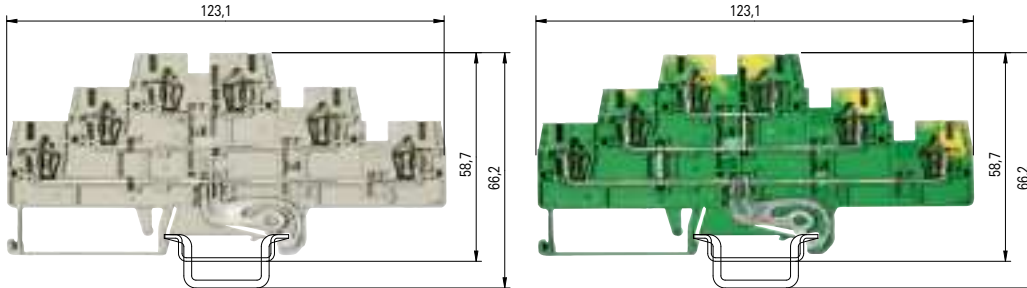

WKFN 2,5 E3/D/D/SL/35 WKFN 2,5 E3/N/D/SL/35

fine-stranded solid V A
0.13–2.5 mm² 0.13–4 mm² 500 V/6 kV/3 24
No. 22-12 AWG 300 V 20
No. 24-12 AWG 300 V 24

5 mm 11 mm



WKFN 2,5 E3/SL/35

fine-stranded solid V A
0.13–2.5 mm² 0.13–4 mm² 500 V/6 kV/3
No. 22-12 AWG 600 V
No. 24-12 AWG 600 V
0.2–2.5 mm² 0.13–4 mm²

5 mm 11 mm



Type	Part No.	Std. Pack	Type	Part No.	Std. Pack
WKFN 2,5 E3/D/D/SL/35	56.703.3355.0	50			
WKFN 2,5 E3/N/D/SL/35	56.703.3255.0	50			
			WKFN 2,5 E/SL/35	56.703.8855.0	50
35x27x7,5 EN 60715	98.300.0000.0	1	35x27x7,5 EN 60715	98.300.0000.0	1
35x24x15 EN 60715	98.360.0000.0	1	35x24x15 EN 60715	98.360.0000.0	1
9708/2 S35	Z5.522.8553.0	100	9708/2 S35	Z5.522.8553.0	100
WEF 1/35	Z5.523.9353.0	100	WEF 1/35	Z5.523.9353.0	100
APFN 2,5 E3	07.312.7555.0	10			
			APFN 2,5 E3 GRÜN	07.312.7555.7	10
TWFN 2,5 E3	07.312.7655.0	10			
IVB WKF 2,5–2	Z7.280.6227.0	10			
IVB WKF 2,5–3	Z7.280.6327.0	10			
IVB WKF 2,5–4	Z7.280.6427.0	10			
IVB WKF 2,5–5	Z7.280.6527.0	10			
IVB WKF 2,5–10	Z7.280.7027.0	20			
IVB WKF–V	Z7.261.1127.0	10			
LELN 2,5/1 WEISS	05.564.3755.0	100	LELN 2,5/1 WEISS	05.564.3755.0	100
LELN 2,5/2 GRAU	05.564.3855.0	100	LELN 2,5/2 GRAU	05.564.3855.0	100
LELN 2,5/3 SCHWARZ	05.564.3955.0	100	LELN 2,5/3 SCHWARZ	05.564.3955.0	100
ADFN 2,5/4 GELB	04.343.8353.8	10	ADFN 2,5/4 GELB	04.343.8353.8	10
BT 5/3	04.243.0755.0	100	BT 5/3	04.243.0755.0	100
PS WKC/F	Z1.299.9753.0	10	PS WKC/F	Z1.299.9753.0	10
ST 2/2,3	Z5.553.2921.0	10	ST 2/2,3	Z5.553.2921.0	10
DIN 5264 B 0,6x3,5	06.502.4000.0	5	DIN 5264 B 0,6x3,5	06.502.4000.0	5
DIN 5264 B 0,6x3,5 M	06.502.5000.0	10	DIN 5264 B 0,6x3,5 M	06.502.5000.0	10

WKFN 2,5 E3/35

Block color: gray

	Function Color ID	
	Function	Color ID
Upper tier	Feed-through	gray
center tier	Feed-through	gray
Lower tier	Feed-through	gray

WKFN 2,5 E3/VB/35

Block color: black

	Function Color ID	
	Function	Color ID
Upper tier	Feed-through	black
center tier	vertically jumpered	black
Lower tier		black

WKFN 2,5 E3/D/D/SL/35

Block color: gray

	Function Color ID	
	Function	Color ID
Upper tier	Feed-through	gray
center tier	Feed-through	gray
Lower tier	Ground conductor	green/yellow

WKFN 2,5 E3/N/D/SL/35

Block color: gray

	Function Color ID	
	Function	Color ID
Upper tier	Feed-through	blue
center tier	Feed-through	gray
Lower tier	Ground conductor	green/yellow

WKFN 2,5 E3/SL/35

Block color: green/yellow

	Function Color ID	
	Function	Color ID
Upper tier	Ground conductor	green/yellow
center tier	vertically jumpered	green/yellow
Lower tier		green/yellow

Multi-tier terminal blocks with tension spring connection

fasis

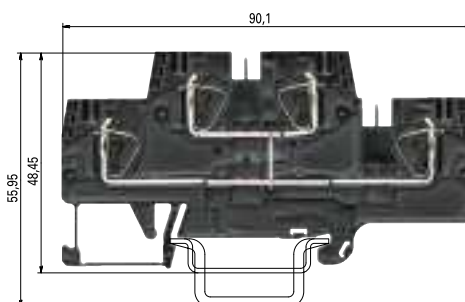
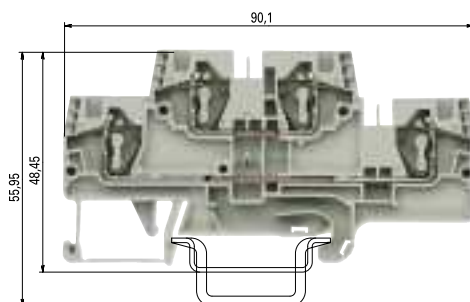

0344 Ex II 2GD IM2

Ex e I/II

EN 60 947-7-1:2002

UL ratings

field/factory wiring

CSA ratings

PTB 05 ATEX 1104 U1) EN 60 079-0/EN 60 079-7

Width

Wire strip length

Approvals

WKFN 4 E/35 WKFN 4 E/N/D/35

	fine-stranded	solid	V	A
0.13–4 mm ²	0.13–6 mm ²	500 V/6 kV/3	32	
No. 24-10 AWG		300 V	30	
No. 24-10 AWG		300 V	32	
0.13–4 mm ²	0.2–6 mm ²	440/352*	27/29 ²⁾	
6 mm			11 mm	

PTB

WKFN 4 E/VB/35

	fine-stranded	solid	V	A
0.13–4 mm ²	0.13–6 mm ²	500 V/6 kV/3	32	
No. 24-10 AWG		600 V	30	
No. 24-10 AWG		300 V	32	
0.13–4 mm ²	0.2–6 mm ²	440	30/31 ²⁾	
6 mm			11 mm	

PTB

		Type	Part No.	Std. Pack	Type	Part No.	Std. Pack
Multi-tier block	gray	WKFN 4 E/35	56.704.7055.0	100			
Multi-tier block, vertically connected	black				WKFN 4 E/VB/35	56.704.6955.1	100
Multi-tier block, combined	gray	WKFN 4 E/N/D/35	56.704.7655.0	100			
Multi-tier block, combined	gray						
Multi-tier ground block	green/yellow						
Accessories							
1. Mounting rail 35, 7.5 mm high	L = 2 m	35x27x7,5 EN 60715	98.300.0000.0	1	35x27x7,5 EN 60715	98.300.0000.0	1
Mounting rail 35, 15 mm high	L = 2 m	35x24x15 EN 60715	98.360.0000.0	1	35x24x15 EN 60715	98.360.0000.0	1
2. End clamp TS 35, with screw	8 mm wide	9708/2 S35	Z5.522.8553.0	100	9708/2 S35	Z5.522.8553.0	100
End clamp TS 35, without screw	8 mm wide	WEF 1/35	Z5.523.9353.0	100	WEF 1/35	Z5.523.9353.0	100
3. End plate	1,5 mm wide	APFN 4 E...	07.312.9655.0	10	APFN 4 E...	07.312.9655.0	10
	1,5 mm wide						
	1,5 mm wide						
4. Partition plate	1,5 mm wide	TWFN 4 E...	07.312.9755.0	10	TWFN 4 E...	07.312.9755.0	10
	1,5 mm wide						
5. Cross connector	2 pole	IVB WKF 4–2	Z7.261.1227.0	10	IVB WKF 4–2	Z7.261.1227.0	10
insulated	3 pole	IVB WKF 4–3	Z7.261.1327.0	10	IVB WKF 4–3	Z7.261.1327.0	10
	4 pole	IVB WKF 4–4	Z7.261.1427.0	10	IVB WKF 4–4	Z7.261.1427.0	10
	5 pole	IVB WKF 4–5	Z7.261.1527.0	10	IVB WKF 4–5	Z7.261.1527.0	10
	6 pole	IVB WKF 4–6	Z7.261.1627.0	10	IVB WKF 4–6	Z7.261.1627.0	10
	7 pole	IVB WKF 4–7	Z7.261.1727.0	20	IVB WKF 4–7	Z7.261.1727.0	20
	8 pole	IVB WKF 4–8	Z7.261.1827.0	20	IVB WKF 4–8	Z7.261.1827.0	20
	9 pole	IVB WKF 4–9	Z7.261.1927.0	20	IVB WKF 4–9	Z7.261.1927.0	20
	10 pole	IVB WKF 4–10	Z7.261.2027.0	20	IVB WKF 4–10	Z7.261.2027.0	20
6. Vertical cross connector	1 pole	IVB WKF-V*)	Z7.261.1127.0	10			
7. Wire entry guide	0.13–0.2 mm ²	LEL 4/1 WEISS	05.561.8553.0	100	LEL 4/1 WEISS	05.561.8553.0	100
	0.25–0.5 mm ²	LEL 4/2 GRAU	05.561.8653.0	100	LEL 4/2 GRAU	05.561.8653.0	100
	0.75–1.0 mm ²	LEL 4/3 SCHWARZ	05.561.8753.0	100	LEL 4/3 SCHWARZ	05.561.8753.0	100
8. Cover with warning symbol over 4 blocks		ADF 4/4 GELB	04.343.6153.8	10	ADF 4/4 GELB	04.343.6153.8	10
9. Screwdriver, uninsulated		DIN 5264 B 0,6x3,5	06.502.4000.0	5	DIN 5264 B 0,6x3,5	06.502.4000.0	5
Screwdriver, uninsulated, MINI		DIN 5264 B 0,6x3,5 M	06.502.5000.0	10	DIN 5264 B 0,6x3,5 M	06.502.5000.0	10
Marking accessories see page 76–79							

¹⁾ Follow the Ex installation instructions on the cover page

²⁾ 1. value at 40 K/2. value at 45 K

* When using cross connectors on the upper tier

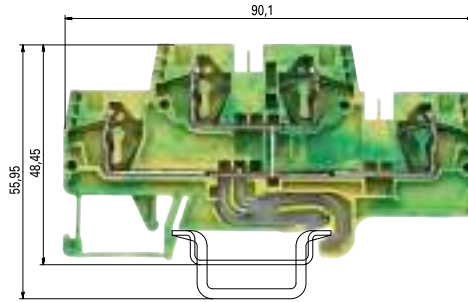
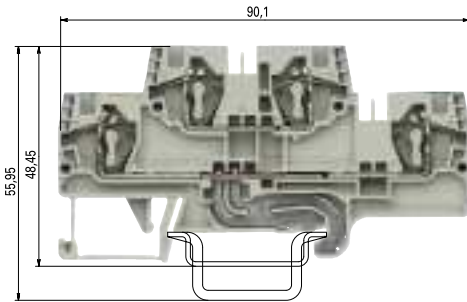

WKFN 4 E/D/SL/35 WKFN 4 E/N/SL/35

fine-stranded	solid	V	A
0.13–4 mm ²	0.13–6 mm ²	500 V/6 kV/3	32
No. 24-10 AWG		300 V	30
No. 24-10 AWG		300 V	32

6 mm 11 mm
 PiB

WKFN 4 E/SL/35

fine-stranded	solid	V	A
0.13–4 mm ²	0.13–6 mm ²	500 V/6 kV/3	
No. 24-10 AWG		600 V	
No. 24-10 AWG		600 V	
0.13–4 mm ²	0.2–6 mm ²		

6 mm 11 mm
 PiB

Type	Part No.	Std. Pack	Type	Part No.	Std. Pack
WKFN 4 E/D/SL/35	56.704.7855.0	100			
WKFN 4 E/N/SL/35	56.704.7755.0	100			
			WKFN 4 E SL/35	56.704.9255.0	100
35x27x7,5 EN 60715	98.300.0000.0	1	35x27x7,5 EN 60715	98.300.0000.0	1
35x24x15 EN 60715	98.360.0000.0	1	35x24x15 EN 60715	98.360.0000.0	1
9708/2 S35	Z5.522.8553.0	100	9708/2 S35	Z5.522.8553.0	100
WEF 1/35	Z5.523.9353.0	100	WEF 1/35	Z5.523.9353.0	100
APFN 4 E...	07.312.9655.0	10			
			APFN 4 E...	07.312.9655.7	10
TWFN 4 E...	07.312.9755.0	10			
IVB WKF 4–2	Z7.261.1227.0	10			
IVB WKF 4–3	Z7.261.1327.0	10			
IVB WKF 4–4	Z7.261.1427.0	10			
IVB WKF 4–5	Z7.261.1527.0	10			
IVB WKF 4–6	Z7.261.1627.0	10			
IVB WKF 4–7	Z7.261.1727.0	20			
IVB WKF 4–8	Z7.261.1827.0	20			
IVB WKF 4–9	Z7.261.1927.0	20			
IVB WKF 4–10	Z7.261.2027.0	20			
LEL 4/1 WEISS	05.561.8553.0	100	LEL 4/1 WEISS	05.561.8553.0	100
LEL 4/2 GRAU	05.561.8653.0	100	LEL 4/2 GRAU	05.561.8653.0	100
LEL 4/3 SCHWARZ	05.561.8753.0	100	LEL 4/3 SCHWARZ	05.561.8753.0	100
ADF 4/4 GELB	04.343.6153.8	10	ADF 4/4 GELB	04.343.6153.8	10
DIN 5264 B 0,6x3,5	06.502.4000.0	5	DIN 5264 B 0,6x3,5	06.502.4000.0	5
DIN 5264 B 0,6x3,5 M	06.502.5000.0	10	DIN 5264 B 0,6x3,5 M	06.502.5000.0	10

³⁾ When cross connectors are used acc. to EN 60079-0 and EN60079-7 the current must be reduced to 2 A at 45 K.

WKFN 4 E/35

Block color: gray

	Function	Color ID
Upper tier	Feed-through	gray
Lower tier	Feed-through	gray

WKFN 4 E/N/D/35

Block color: gray

	Function	Color ID
Upper tier	Feed-through	blue
Lower tier	Feed-through	gray

WKFN 4 E/VB/35

Block color: black

	Function	Color ID
Upper tier	Feed-through	black
Lower tier	vertically jumpered	black

WKFN 4 E/D/SL/35

Block color: gray

	Function	Color ID
Upper tier	Feed-through	gray
Lower tier	Ground conductor	green/yellow

WKFN 4 E/N/SL/35

Block color: gray

	Function	Color ID
Upper tier	Feed-through	blue
Lower tier	Ground conductor	green/yellow

WKFN 4 E/SL/35

Block color: green/yellow

	Function	Color ID
Upper tier	Ground conductor	green/yellow
Lower tier	vertically jumpered	green/yellow

Multi-tier function blocks with tension spring connection

fasis

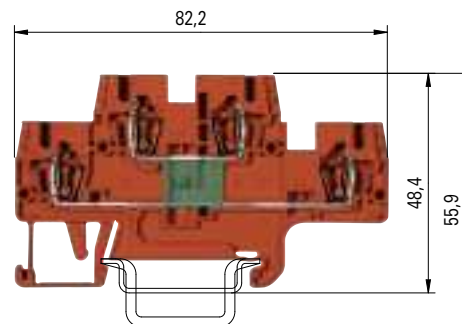
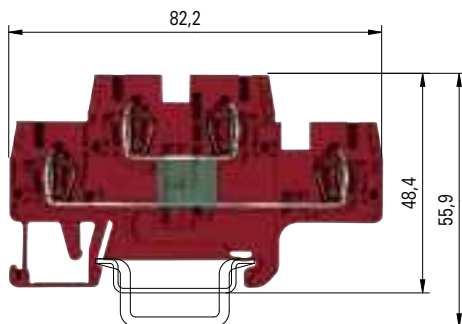

WKFN 2,5 E...G

fine-stranded solid V A
 0.13–2.5 mm² 0.13–4 mm²
 No. 22-12 AWG
 No. 24-12 AWG
 5 mm 11 mm



EN 60 947-7-1:2002

UL ratings
 CSA ratings
 Width
 Approvals

field/factory wiring

Wire strip length

The multi-tier block is available on request as a function block for most different switching tasks.

Function block	Type	Part No.	Std. Pack
Function block red	WKFN 2,5 E.../35	56.703.XX55.5	100
Function block orange	WKFN 2,5 E.../35	56.703.XX55.9	100
Accessories			
1. Mounting rail 35, 7.5 mm high	L = 2 m	35x27x7,5 EN 60715	98.300.0000.0 1
Mounting rail 35, 15 mm high	L = 2 m	35x24x15 EN 60715	98.360.0000.0 1
2. End clamp TS 35, with screw	8 mm wide	9708/2 S35	Z5.522.8553.0 100
End clamp TS 35, without screw	8 mm wide	WEF 1/35	Z5.523.9353.0 100
3. End plate	gray	APFN 2,5 E	07.312.7355.0 10
	blue		
	green		
4. Partition plate	gray	TWFN 2,5 E	07.312.7455.0 10
	blue		
5. Cross connector	2 pole	IVB WKF 2,5–2	Z7.280.6227.0 10
insulated	3 pole	IVB WKF 2,5–3	Z7.280.6327.0 10
	4 pole	IVB WKF 2,5–4	Z7.280.6427.0 10
	5 pole	IVB WKF 2,5–5	Z7.280.6527.0 10
	6 pole	IVB WKF 2,5–6	Z7.280.6627.0 10
	7 pole	IVB WKF 2,5–7	Z7.280.6727.0 20
	8 pole	IVB WKF 2,5–8	Z7.280.6827.0 20
	9 pole	IVB WKF 2,5–9	Z7.280.6927.0 20
	10 pole	IVB WKF 2,5–10	Z7.280.7027.0 20
Vertical cross connector	1 pole	IVB WKF-V	Z7.261.1127.0 10
6. Wire entry guide	0.13–0.2 mm ²	LELN 2,5/1 WEISS	05.564.3755.0 100
	0.25–0.5 mm ²	LELN 2,5/2 GRAU	05.564.3855.0 100
	0.75–1.0 mm ²	LELN 2,5/3 SCHWARZ	05.564.3955.0 100
7. Cover with warning symbol over 4 blocks		ADFN 2,5/4 GELB	04.343.8353.8 10
8. Marking tag carrier, 2-fold		BT 4/2	04.243.0953.0 100
9. Test adapter, modular		PS WKCF	Z1.299.9753.0 10
10. Test plug		ST 2/2,3	Z5.553.2921.0 10
11. Screwdriver, uninsulated		DIN 5264 B 0,6x3,5	06.502.4000.0 5
Screwdriver, uninsulated, MINI		DIN 5264 B 0,6x3,5 M	06.502.5000.0 10
Marking accessories see page 76–79			

Function diagram

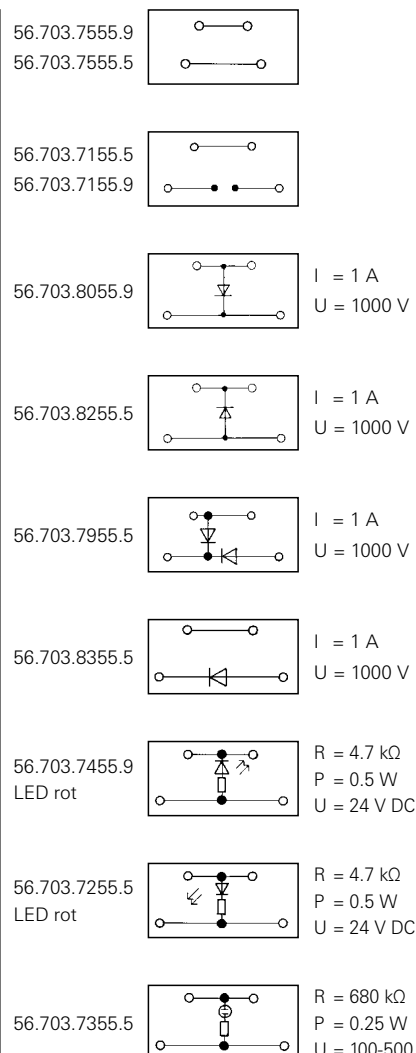

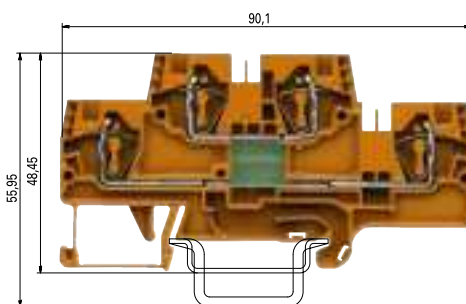
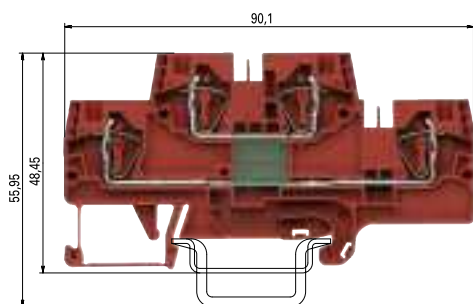

WKFN 4 E /35...

fine-stranded solid V A
 0.13–4 mm² 0.13–6 mm²
 No. 24-10 AWG
 No. 24-10 AWG
 6 mm 11 mm

EN 60 947-7-1:2002

UL ratings
 CSA ratings
 Width
 Approvals

field/factory wiring

Wire strip length

The multi-tier block is available on request as a function block for most different switching tasks.

Function block	Type	Part No.	Std. Pack
Function block red	WKFN 4 E /35...	56.704.XX55.5	100
Function block orange	WKFN 4 E /35...	56.704.XX55.9	100
Accessories			
1. Mounting rail 35, 7.5 mm high	L = 2 m	35x27x7,5 EN 60715	98.300.0000.0 1
Mounting rail 35, 15 mm high	L = 2 m	35x24x15 EN 60715	98.360.0000.0 1
2. End clamp TS 35, with screw	8 mm wide	9708/2 S35	Z5.522.8553.0 100
End clamp TS 35, without screw	8 mm wide	WEF 1/35	Z5.523.9353.0 100
3. End plate	gray	APFN 4 E...	07.312.9655.0 10
	blue		
	green		
4. Partition plate	gray	TWFN 4 E...	07.312.9755.0 10
	blue		
5. Cross connector	2 pole	IVB WKF 4–2	Z7.261.1227.0 10
insulated	3 pole	IVB WKF 4–3	Z7.261.1327.0 10
	4 pole	IVB WKF 4–4	Z7.261.1427.0 10
	5 pole	IVB WKF 4–5	Z7.261.1527.0 10
	6 pole	IVB WKF 4–6	Z7.261.1627.0 10
	7 pole	IVB WKF 4–7	Z7.261.1727.0 20
	8 pole	IVB WKF 4–8	Z7.261.1827.0 20
	9 pole	IVB WKF 4–9	Z7.261.1927.0 20
	10 pole	IVB WKF 4–10	Z7.261.2027.0 20
Vertical cross connector	1 pole		
6. Wire entry guide	0.13–0.2 mm ²	LEL 4/1 WEISS	05.561.8553.0 100
	0.25–0.5 mm ²	LEL 4/2 GRAU	05.561.8653.0 100
	0.75–1.0 mm ²	LEL 4/3 SCHWARZ	05.561.8753.0 100
7. Cover with warning symbol over 4 blocks		ADF 4/4 GELB	04.343.6153.8 10
8. Marking tag carrier, 2-fold		BT 4/2	04.243.0953.0 100
9. Test adapter, modular		PS WKCF	Z1.299.9753.0 10
10. Test plug		ST 2/2,3	Z5.553.2921.0 10
11. Screwdriver, uninsulated		DIN 5264 B 0,6x3,5	06.502.4000.0 5
Screwdriver, uninsulated, MINI		DIN 5264 B 0,6x3,5 M	06.502.5000.0 10

Function diagram

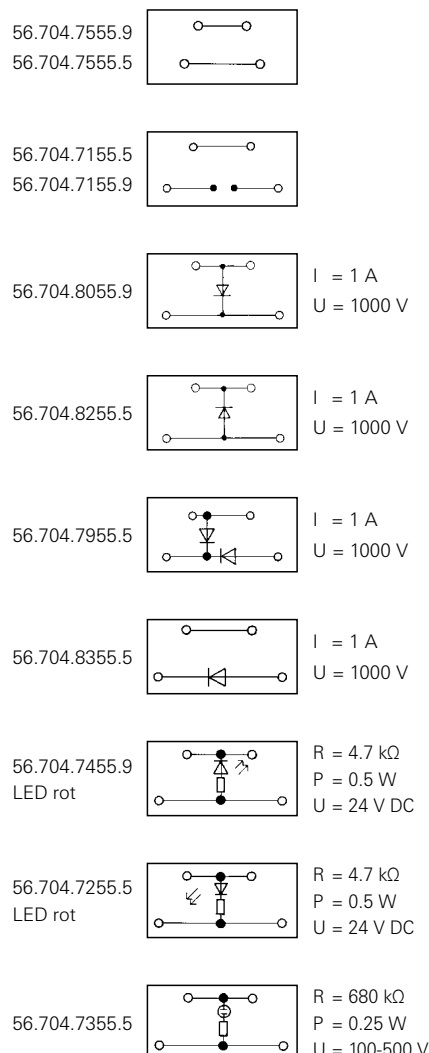

Disconnect terminal blocks with tension spring connection

fasis

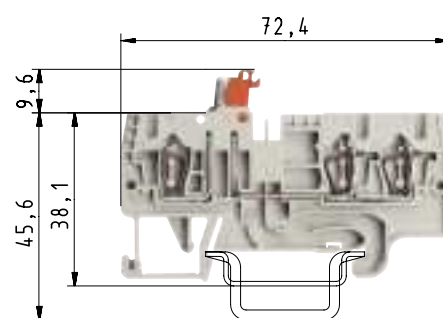
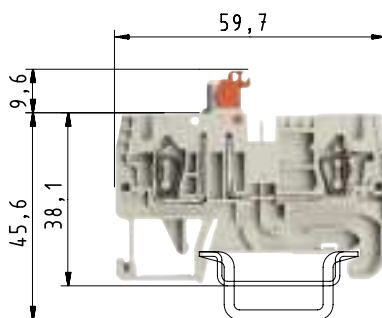

0344 Ex II 2GD IM2

Ex e I/II

EN 60 947-7-1:2002

UL ratings

CSA ratings

KEMA 01 ATEX 2087 U¹⁾ EN 60 079-0/EN 60 079-3

Width

Approvals

field/factory wiring

Wire strip length

WKFN 2,5 TKM/35

fine-stranded solid	V	A
0.14–2,5 mm ² 0.2–4 mm ²	630 V/6 kV/3	20
No. 24-12 AWG	300 V	19
No. 24-12 AWG	300 V	20

5 mm



11 mm

WKFN 2,5 TKM 1/2/35

fine-stranded solid	V	A
0.14–2,5 mm ² 0.2–4 mm ²	630 V/6 kV/3	20
No. 24-12 AWG	300 V	19
No. 24-12 AWG	300 V	20

5 mm



11 mm

Disconnect terminal block		Type	Part No.	Std. Pack	WKFN 2,5 TKM 1/2/35	
gray	WKFN 2,5 TKM/35	56.703.5355.0	100	Type	Part No.	Std. Pack
gray	WKFN 2,5 TKM 1/2/35	56.703.5455.0	100			
Accessories						
1. Mounting rail 35, Din rail 7.5 mm high	L = 2 m	35x27x7,5 EN 60715	98.300.0000.0	1	35x27x7,5 EN 60715	98.300.0000.0 1
Mounting rail 35, Din rail 15 mm high	L = 2 m	35x24x15 EN 60715	98.360.0000.0	1	35x24x15 EN 60715	98.360.0000.0 1
2. End clamp TS 35, with screw	8 mm wide	9708/2 S35	Z5.522.8553.0	100	9708/2 S35	Z5.522.8553.0 100
End clamp TS 35, without screw	8 mm wide	WEF 1/35	Z5.523.9353.0	100	WEF 1/35	Z5.523.9353.0 100
3. End plate	gray	APFN 2,5 D1/2	07.312.6955.0	10	APFN 2,5 D2/2	07.312.7155.0 10
	blue					
4. Partition	gray	TWFN 2,5 D1/2	07.312.7055.0	10	TWFN 2,5 D2/2	07.312.7255.0 10
	blue					
5. Cross connector	2 pole	IVB WKF 2,5–2	Z7.280.6227.0	10	IVB WKF 2,5–2	Z7.280.6227.0 10
insulated	3 pole	IVB WKF 2,5–3	Z7.280.6327.0	10	IVB WKF 2,5–3	Z7.280.6327.0 10
	4 pole	IVB WKF 2,5–4	Z7.280.6427.0	10	IVB WKF 2,5–4	Z7.280.6427.0 10
	5 pole	IVB WKF 2,5–5	Z7.280.6527.0	10	IVB WKF 2,5–5	Z7.280.6527.0 10
	6 pole	IVB WKF 2,5–6	Z7.280.6627.0	10	IVB WKF 2,5–6	Z7.280.6627.0 10
	7 pole	IVB WKF 2,5–7	Z7.280.6727.0	20	IVB WKF 2,5–7	Z7.280.6727.0 20
	8 pole	IVB WKF 2,5–8	Z7.280.6827.0	20	IVB WKF 2,5–8	Z7.280.6827.0 20
	9 pole	IVB WKF 2,5–9	Z7.280.6927.0	20	IVB WKF 2,5–9	Z7.280.6927.0 20
	10 pole	IVB WKF 2,5–10	Z7.280.7027.0	20	IVB WKF 2,5–10	Z7.280.7027.0 20
6. Wire entry guide	0.13–0.2 mm ²	LELN 2,5/1 WEISS	05.564.3753.0	100	LELN 2,5/1 WEISS	05.564.3753.0 100
	0.25–0.5 mm ²	LELN 2,5/1 GRAU	05.564.3853.0	100	LELN 2,5/1 GRAU	05.564.3853.0 100
	0.75–1.0 mm ²	LELN 2,5/1 SCHWARZ	05.564.3953.0	100	LELN 2,5/1 SCHWARZ	05.564.3953.0 100
7. Cover with warning symbol for 4 terminals		ADFN 2,5/4 GELB	04.343.8353.8	10	ADFN 2,5/4 GELB	04.343.8353.8 10
8. Test adapter modular		PS WKC/F	Z1.299.9753.0	10	PS WKC/F	Z1.299.9753.0 10
9. Test plug		ST 2/2,3	Z5.553.2921.0	10	ST 2/2,3	Z5.553.2921.0 10
10. Screwdriver, uninsulated		DIN 5264 B 0,6x3,5	06.502.4000.0	5	DIN 5264 B 0,6x3,5	06.502.4000.0 5
Screwdriver, uninsulated, MINI		DIN 5264 B 0,6x3,5 M	06.502.5000.0	10	DIN 5264 B 0,6x3,5 M	06.502.5000.0 10
Marking accessories see page 76–79						
¹⁾ Follow the Ex installation instructions on the cover page						

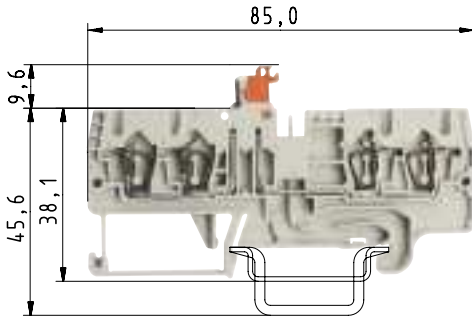

- Potential distribution with standard cross connector IVB WKF 2,5...
- Parallel connection of two cross connectors -> double jumpering
- Potential distributions are possible on one or both sides

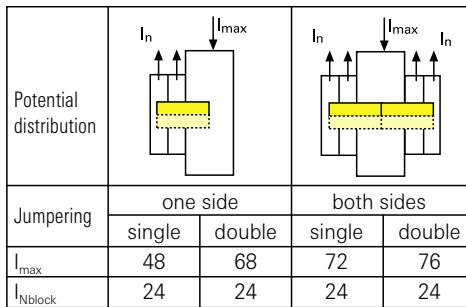

$$I_{max} = \sum I_n \leq \sum I_{Nblock}$$

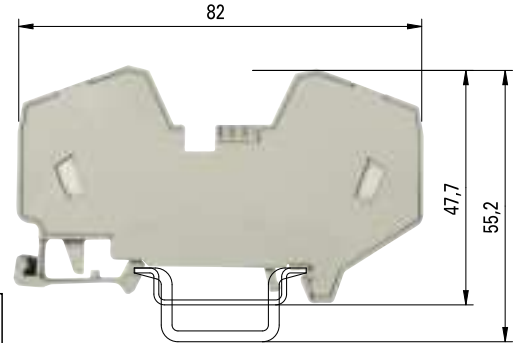

WKFN 16/35 PV/WKFN

fine-stranded	solid/stranded	V	A
4-16 mm ²	4-16 mm ²	800 V/8 kV/3	76
No. 24-4 AWG		600 V	75
No. 12-4 AWG		600 V	78
4-16 mm ²	4-16 mm ²	690 V	64*
12 mm			15 mm

UL SEV NV IEC ATEX

WKFN 2,5 TKM 2/2/35

fine-stranded	solid	V	A
0.14-2.5 mm ²	0.2-4 mm ²	630 V/6 kV/3	20
No. 24-12 AWG		300 V	19
No. 24-12 AWG		300 V	20

5 mm 11 mm

UL IEC

Type	Part No.	Std. Pack	Type	Part No.	Std. Pack
WKFN 2,5 TKM 2/2/35	56.703.5555.0	50	WKFN 16/35/PV/WKFN	56.716.0353.0	20
35x27x7,5 EN 60715	98.300.0000.0	1	35x27x7,5 EN 60715	98.300.0000.0	1
35x24x15 EN 60715	98.360.0000.0	1	35x24x15 EN 60715	98.360.0000.0	1
9708/2 S35	Z5.522.8553.0	100	9708/2 S35	Z5.522.8553.0	100
WEF 1/35	Z5.523.9353.0	100	WEF 1/35	Z5.523.9353.0	100
APFN 2,5 TKM D2/2	07.313.0055.0	10			
TWFN 2,5 TKM D2/2	07.313.0155.0	10			
IVB WKF 2,5-2	Z7.280.6227.0	10	IVB WKF 2,5-2	Z7.280.6227.0	10
IVB WKF 2,5-3	Z7.280.6327.0	10	IVB WKF 2,5-3	Z7.280.6327.0	10
IVB WKF 2,5-4	Z7.280.6427.0	10	IVB WKF 2,5-4	Z7.280.6427.0	10
IVB WKF 2,5-5	Z7.280.6527.0	10	IVB WKF 2,5-5	Z7.280.6527.0	10
IVB WKF 2,5-6	Z7.280.6627.0	10	IVB WKF 2,5-6	Z7.280.6627.0	10
IVB WKF 2,5-7	Z7.280.6727.0	20	IVB WKF 2,5-7	Z7.280.6727.0	20
IVB WKF 2,5-8	Z7.280.6827.0	20	IVB WKF 2,5-8	Z7.280.6827.0	20
IVB WKF 2,5-9	Z7.280.6927.0	20	IVB WKF 2,5-9	Z7.280.6927.0	20
IVB WKF 2,5-10	Z7.280.7027.0	20	IVB WKF 2,5-10	Z7.280.7027.0	20
LELN 2,5/1 WEISS	05.564.3753.0	100			
LELN 2,5/1 GRAU	05.564.3853.0	100			
LELN 2,5/1 SCHWARZ	05.564.3953.0	100			
ADFN 2,5/4 GELB	04.343.8353.8	10	ADFN 16/4 GELB	04.343.6653.8	10
PS WKC/F	Z1.299.9753.0	10			
ST 2/2,3	Z5.553.2921.0	10	ST 2/2,3	Z5.553.2921.0	10
DIN 5264 B 0,6x3,5	06.502.4000.0	5	DIN 5264 B 1x5,5	06.502.4200.0	5
DIN 5264 B 0,6x3,5 M	06.502.5000.0	10			

* Type-specific output currents upon request

Multi-tier disconnect terminal blocks with tension spring connection

fasis **STS**

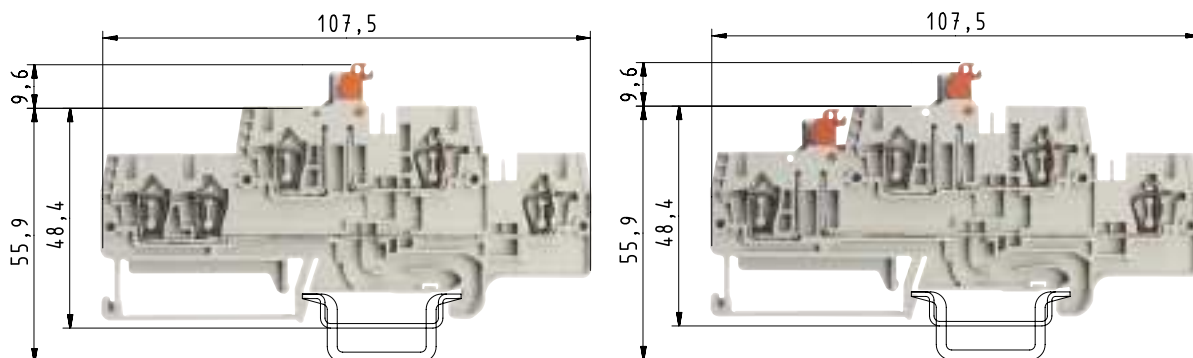

WKFN 2,5 TKM E1/35

fine-stranded	solid	V	A
0.14–2.5 mm ²	0.2–4 mm ²	500 V/6 kV/3	20
No. 24-12 AWG		300 V	19
No. 24-12 AWG		300 V	20
5 mm			11 mm



WKFN 2,5 TKM E2/35

fine-stranded	solid	V	A
0.14–2.5 mm ²	0.2–4 mm ²	500 V/6 kV/3	19
No. 24-12 AWG		300 V	19
No. 24-12 AWG		300 V	19
5 mm			11 mm



EN 60 947-7-1:2002

UL ratings

CSA ratings

Width

Approvals

field/factory wiring

Wire strip length

Disconnect terminal block		Type	Part No.	Std. Pack	Type	Part No.	Std. Pack
gray		WKFN 2,5 TKM E1/35	56.703.6555.0	50	WKFN 2,5 TKM E2/35	56.703.6655.0	50
Accessories							
1. Mounting rail 35, Din rail 7.5 mm high	L = 2 m	35x27x7,5 EN 60715	98.300.0000.0	1	35x27x7,5 EN 60715	98.300.0000.0	1
Mounting rail 35, Din rail 15 mm high	L = 2 m	35x24x15 EN 60715	98.360.0000.0	1	35x24x15 EN 60715	98.360.0000.0	1
2. End clamp TS 35, with screw	8 mm wide	9708/2 S35	Z5.522.8553.0	100	9708/2 S35	Z5.522.8553.0	100
End clamp TS 35, without screw	8 mm wide	WEF 1/35	Z5.523.9353.0	100	WEF 1/35	Z5.523.9353.0	100
3. End plate	gray	APFN 2,5 E1/2	07.312.7755.0	10	APFN 2,5 E1/2	07.312.7755.0	10
	blue						
4. Partition	gray	TWFN 2,5 E1/2	07.312.7855.0	10	TWFN 2,5 E1/2	07.312.7855.0	10
	blue						
5. Cross connector	2 pole	IVB WKF 2,5–2	Z7.280.6227.0	10	IVB WKF 2,5–2	Z7.280.6227.0	10
insulated	3 pole	IVB WKF 2,5–3	Z7.280.6327.0	10	IVB WKF 2,5–3	Z7.280.6327.0	10
	4 pole	IVB WKF 2,5–4	Z7.280.6427.0	10	IVB WKF 2,5–4	Z7.280.6427.0	10
	5 pole	IVB WKF 2,5–5	Z7.280.6527.0	10	IVB WKF 2,5–5	Z7.280.6527.0	10
	6 pole	IVB WKF 2,5–6	Z7.280.6627.0	10	IVB WKF 2,5–6	Z7.280.6627.0	10
	7 pole	IVB WKF 2,5–7	Z7.280.6727.0	20	IVB WKF 2,5–7	Z7.280.6727.0	20
	8 pole	IVB WKF 2,5–8	Z7.280.6827.0	20	IVB WKF 2,5–8	Z7.280.6827.0	20
	9 pole	IVB WKF 2,5–9	Z7.280.6927.0	20	IVB WKF 2,5–9	Z7.280.6927.0	20
	10 pole	IVB WKF 2,5–10	Z7.280.7027.0	20	IVB WKF 2,5–10	Z7.280.7027.0	20
Vertical cross connector	1 pole	IVB WKF-V	Z7.261.1127.0	10	IVB WKF-V	Z7.261.1127.0	10
6. Wire entry guide	0.13–0.2 mm ²	LELN 2,5/1 WEISS	05.564.3753.0	100	LELN 2,5/1 WEISS	05.564.3753.0	100
	0.25–0.5 mm ²	LELN 2,5/1 GRAU	05.564.3853.0	100	LELN 2,5/1 GRAU	05.564.3853.0	100
	0.75–1.0 mm ²	LELN 2,5/1 SCHWARZ	05.564.3953.0	100	LELN 2,5/1 SCHWARZ	05.564.3953.0	100
7. Cover with warning symbol for 4 terminals		ADFN 2,5/4 GELB	04.343.8353.8	10	ADFN 2,5/4 GELB	04.343.8353.8	10
8. Test adapter modular		PS WKC/F	Z1.299.9753.0	10	PS WKC/F	Z1.299.9753.0	10
9. Test plug		ST 2/2,3	Z5.553.2921.0	10	ST 2/2,3	Z5.553.2921.0	10
10. Screwdriver, uninsulated		DIN 5264 B 0,6x3,5	06.502.4000.0	5	DIN 5264 B 0,6x3,5	06.502.4000.0	5
Screwdriver, uninsulated, MINI		DIN 5264 B 0,6x3,5 M	06.502.5000.0	10	DIN 5264 B 0,6x3,5 M	06.502.5000.0	10
Marking accessories see page 76–79							

fasis

Fuse blocks with tension spring connection

fasis

¹⁾ When selecting G fuse inserts, make sure that the specified maximum power is not exceeded.

The current is determined by the inserted fuse.

²⁾ The voltage range is determined by the built-in LED display.

Depending on the application and the installation method, the circumstances for increased temperature must be checked in the closed fuse holders.

Higher ambient temperatures are an additional load for the fuse inserts. Therefore, the reduction of the rated current must be considered accordingly in these applications.

Indicator (24 V): LED, red
current consumption: 10.3 mA

Indicator (220 V): LED, red
current consumption: 0.3 mA

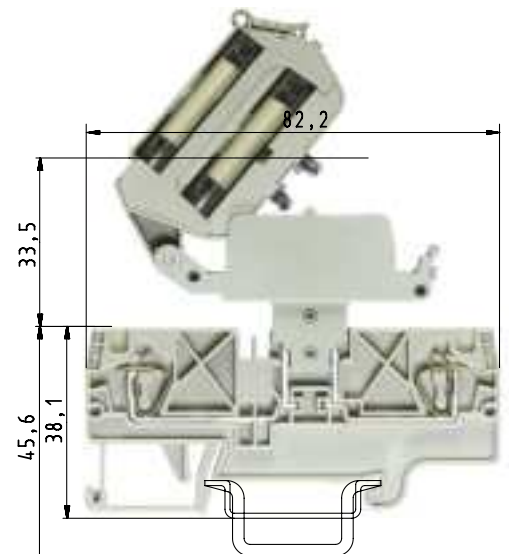
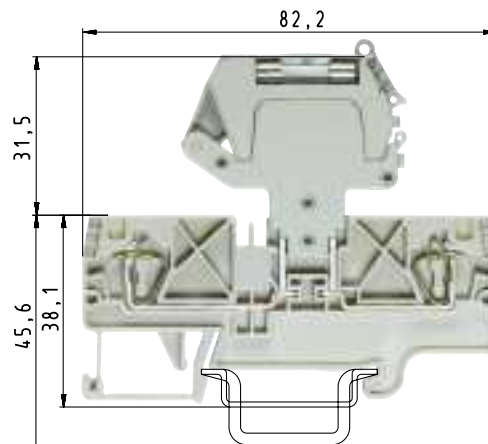

WKFN 4 TKG with THSi 5 x 20

fine-stranded solid V A
0.13–4 mm² 0.13–6 mm² 500 V/8 kV/3 ¹⁾

6 mm 11 mm
 pending

WKFN 4 TKG with THSi 6,3 x 32

fine-stranded solid V A
0.13–4 mm² 0.13–6 mm² 500 V/8 kV/3 ¹⁾

6 mm 11 mm
 pending

EN 60 947-7-3:2002

UL ratings field/factory wiring

CSA ratings

KEMA 01 ATEX 2087 U¹⁾ EN 60 079-0/EN 60 079-3

Width Wire strip length

Approvals

		Type	Part No.	Std. Pack	Type	Part No.	Std. Pack
Disconnect ground block	gray	WKFN 4 TKG/35	56.704.4055.0	100	WKFN 4 TKG/35	56.704.4055.0	100
Fuse disconnect lever		THSi 5x20	Z1.298.1053.0	10	THSi 6,3x32	Z1.298.1653.0	10
Fuse disconnect lever with LED 12–24 V ²⁾		THSi 5x20 LED24	Z1.298.1153.0	10	THSi 6,3x32 LED24	Z1.298.1753.0	10
Fuse disconnect lever with LED 24–60 V ²⁾		THSi 5x20 LED60	Z1.298.1253.0	10	THSi 6,3x32 LED60	Z1.298.1853.0	10
Fuse disconnect lever with GL 110–250 V ²⁾		THSi 5x20 GL250	Z1.298.1353.0	10	THSi 6,3x32 GL250	Z1.298.1953.0	10
Fuse disconnect lever with GL 500 V ²⁾					THSi 6,3x32 GL500	Z1.298.2053.0	10
Supply block	gray						
Accessories							
1. Mounting rail 35, 7.5 mm high	L = 2 m	35x27x7,5 EN 60715	98.300.0000.0	1	35x27x7,5 EN 60715	98.300.0000.0	1
Mounting rail 35, 15 mm high	L = 2 m	35x24x15 EN 60715	98.360.0000.0	1	35x24x15 EN 60715	98.360.0000.0	1
2. End clamp TS 35, with screw	8 mm wide	9708/2 S35	Z5.522.8553.0	100	9708/2 S35	Z5.522.8553.0	100
End clamp TS 35, screwless	8 mm wide	WEF 1/35	Z5.523.9353.0	100	WEF 1/35	Z5.523.9353.0	100
3. End plate	gray	APFN 4 D2/2	07.312.9055.0	10	APFN 4 D2/2	07.312.9055.0	10
Intermediate plate, 4 mm wide	blue				ZP/WKFN 4 TKG	07.313.1655.0	10
4. Partition plate	gray	TWFN 4 D2/2	07.312.9155.0	10	TWFN 4 D2/2	07.312.9155.0	10
5. Cross connector	2 pole	IVB WKF 4-2	Z7.261.1227.0	10	IVB WKF 4-2	Z7.261.1227.0	10
insulated	3 pole	IVB WKF 4-3	Z7.261.1327.0	10	IVB WKF 4-3	Z7.261.1327.0	10
	4 pole	IVB WKF 4-4	Z7.261.1427.0	10	IVB WKF 4-4	Z7.261.1427.0	10
	5 pole	IVB WKF 4-5	Z7.261.1527.0	10	IVB WKF 4-5	Z7.261.1527.0	10
	6 pole	IVB WKF 4-6	Z7.261.1627.0	10	IVB WKF 4-6	Z7.261.1627.0	10
	7 pole	IVB WKF 4-7	Z7.261.1727.0	20	IVB WKF 4-7	Z7.261.1727.0	20
	8 pole	IVB WKF 4-8	Z7.261.1827.0	20	IVB WKF 4-8	Z7.261.1827.0	20
	9 pole	IVB WKF 4-9	Z7.261.1927.0	20	IVB WKF 4-9	Z7.261.1927.0	20
	10 pole	IVB WKF 4-10	Z7.261.2027.0	20	IVB WKF 4-10	Z7.261.2027.0	20
6. Wire entry guide	0.13–0.2 mm ²	LEL 4/1 WEISS	05.561.8553.0	100	LEL 4/1 WEISS	05.561.8553.0	100
	0.25–0.5 mm ²	LEL 4/2 GRAU	05.561.8653.0	100	LEL 4/2 GRAU	05.561.8653.0	100
	0.75–1.0 mm ²	LEL 4/3 SCHWARZ	05.561.8753.0	100	LEL 4/3 SCHWARZ	05.561.8753.0	100
7. Cover with warning symbol over 4 blocks		ADF 4/4 GELB	04.343.6153.8	10	ADF 4/4 GELB	04.343.6153.8	10
8. Test plug		ST 2/2,3	Z5.553.2921.0	10	ST 2/2,3	Z5.553.2921.0	10
9. Screwdriver, uninsulated		DIN 5264 B 0,6x3,5	06.502.4000.0	5	DIN 5264 B 0,6x3,5	06.502.4000.0	5
Screwdriver, uninsulated, MINI		DIN 5264 B 0,6x3,5 M	06.502.5000.0	10	DIN 5264 B 0,6x3,5 M	06.502.5000.0	10
Marking accessories see page 76–79							

- Potential distribution with standard cross connector IVB WKF 4...
- Parallel connection of two cross connectors -> double jumpering
- Potential distributions are possible on one or both sides

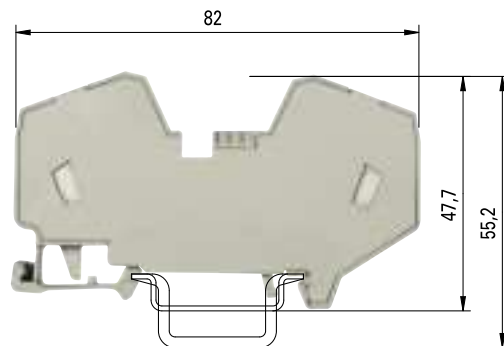

Potential distribution	one side		both sides	
	single	double	single	double
I_{max}	64	76	76	76
I_{Nblock}	32	32	32	32

$$I_{max} = \sum I_n \leq \sum I_{Nblock}$$

WKF 16/35 PV/WKFN

fine-stranded	solid/stranded	V	A
4-16 mm ²	4-16 mm ²	800 V/8 kV/3	76
No. 24-4 AWG		600 V	75
No. 12-4 AWG		600 V	78
4-16 mm ²	4-16 mm ²	690 V	64*
12 mm			15 mm

Type	Part No.	Std. Pack
WKF 16/35 PV/WKFN	56.716.0353.0	20
35x27x7,5 EN 60715	98.300.0000.0	1
35x24x15 EN 60715	98.360.0000.0	1
9708/2 S35	Z5.522.8553.0	100
WEF 1/35	Z5.523.9353.0	100
IVB WKF 4-2	Z7.261.1227.0	10
IVB WKF 4-3	Z7.261.1327.0	10
IVB WKF 4-4	Z7.261.1427.0	10
IVB WKF 4-5	Z7.261.1527.0	10
IVB WKF 4-6	Z7.261.1627.0	10
IVB WKF 4-7	Z7.261.1727.0	20
IVB WKF 4-8	Z7.261.1827.0	20
IVB WKF 4-9	Z7.261.1927.0	20
IVB WKF 4-10	Z7.261.2027.0	20
ADF 16/4 GELB	04.343.6653.8	10
ST 2/2,3	Z5.553.2921.0	10
DIN 5264 B 1,0x5,5	06.502.4200.0	5

* Type-specific output currents upon request

Fuse blocks with tension spring connection

fasis

¹⁾ When selecting G fuse inserts, make sure that the specified maximum power is not exceeded. The current is determined by the inserted fuse.

²⁾ The voltage range is determined by the built-in LED display. Depending on the application and the installation method, the conditions for temperature rise must be checked in the closed fuse holders. Higher ambient temperatures are an additional load for the fuse inserts. Therefore, the reduction of the rated current must be considered accordingly in these applications.

Indicator (24 V): LED, red
current consumption: 10.3 mA

Indicator (220 V): LED, red
current consumption: 0.3 mA

³⁾ Periodic peak voltage 1000 V

Direction of the diode: Anode Cathode⁵⁾
Cathode Anode⁵⁾

⁴⁾ The current load is determined by the component installed.

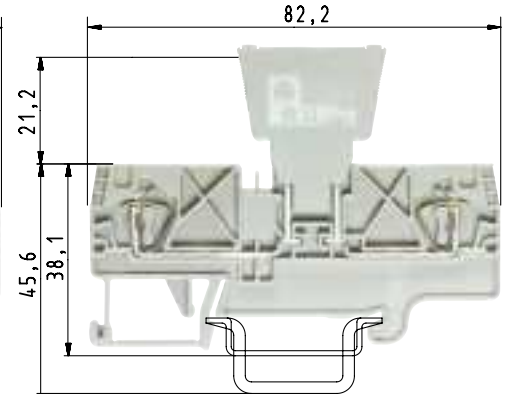
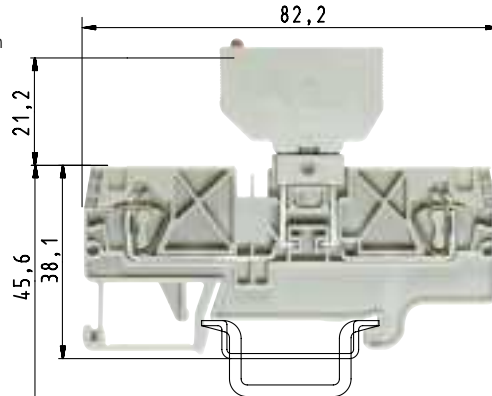

WKFN 4 TKG with SiST

fine-stranded solid V A
0.13–4 mm² 0.13–6 mm² 500 V/8 kV/3²⁾ 1)

6 mm 11 mm
⚡ pending

WKFN 4 TKG with DiST

fine-stranded solid V A
0.13–4 mm² 0.13–6 mm² 500 V/8 kV/3³⁾ 4)

6 mm 11 mm
⚡ pending

EN 60 947-7-3:2002

UL ratings field/factory wiring

CSA ratings

KEMA 01 ATEX 2087 U¹⁾ EN 60 079-0/EN 60 079-3

Width Wire strip length

Approvals

		Type	Part No.	Std. Pack	Type	Part No.	Std. Pack
Disconnect ground block	gray	WKFN 4 TKG/35	56.704.4055.0	100	WKFN 4 TKG/35	56.704.4055.0	100
Fuse holder for fuse 5 x 20	gray	Si ST	Z1.299.4055.0	10			
Fuse holder with indicator (24 V)	gray	Si ST LED	Z1.299.4155.0	10			
Fuse holder with indicator (220 V)	gray	Si ST GL	Z1.299.4255.0	10			
Diode plug —empty	$J_{max} = 10 A^{4)}$ gray				DIST ...	Z1.299.3055.0	10
Diode plug —diode	$J_{max} = 1 A^{4)}$ gray				DIST-1 N 4007-1 ³⁾	Z1.299.3155.0	10
Diode plug —diode	$J_{max} = 1 A^{4)}$ gray				DIST-1 N 4007-2 ³⁾	Z1.299.3355.0	10
Diode plug with jumper	$J_{max} = 10 A^{4)}$ gray				DIST-D	Z1.299.3255.0	10
Supply block	gray						
Accessories							
1. Mounting rail 35, 7.5 mm high	L = 2 m	35x27x7,5 EN 60715	98.300.0000.0	1	35x27x7,5 EN 60715	98.300.0000.0	1
Mounting rail 35, 15 mm high	L = 2 m	35x24x15 EN 60715	98.360.0000.0	1	35x24x15 EN 60715	98.360.0000.0	1
2. End clamp TS 35, with screw	8 mm wide	9708/2 S35	Z5.522.8553.0	100	9708/2 S35	Z5.522.8553.0	100
End clamp TS 35, screwless	8 mm wide	WEF 1/35	Z5.523.9353.0	100	WEF 1/35	Z5.523.9353.0	100
3. End plate	gray	APFN 4 D2/2	07.312.9055.0	10	APFN 4 D2/2	07.312.9055.0	10
4. Partition plate		TWFN 4 D2/2	07.312.9155.0	10	TWFN 4 D2/2	07.312.9155.0	10
5. Cross connector	2 pole	IVB WKF 4-2	Z7.261.1227.0	10	IVB WKF 4-2	Z7.261.1227.0	10
insulated	3 pole	IVB WKF 4-3	Z7.261.1327.0	10	IVB WKF 4-3	Z7.261.1327.0	10
	4 pole	IVB WKF 4-4	Z7.261.1427.0	10	IVB WKF 4-4	Z7.261.1427.0	10
	5 pole	IVB WKF 4-5	Z7.261.1527.0	10	IVB WKF 4-5	Z7.261.1527.0	10
	6 pole	IVB WKF 4-6	Z7.261.1627.0	10	IVB WKF 4-6	Z7.261.1627.0	10
	7 pole	IVB WKF 4-7	Z7.261.1727.0	20	IVB WKF 4-7	Z7.261.1727.0	20
	8 pole	IVB WKF 4-8	Z7.261.1827.0	20	IVB WKF 4-8	Z7.261.1827.0	20
	9 pole	IVB WKF 4-9	Z7.261.1927.0	20	IVB WKF 4-9	Z7.261.1927.0	20
	10 pole	IVB WKF 4-10	Z7.261.2027.0	20	IVB WKF 4-10	Z7.261.2027.0	20
6. Wire entry guide	0.13–0.2 mm ²	LEL 4/1 WEISS	05.561.8553.0	100	LEL 4/1 WEISS	05.561.8553.0	100
	0.25–0.5 mm ²	LEL 4/2 GRAU	05.561.8653.0	100	LEL 4/2 GRAU	05.561.8653.0	100
	0.75–1.0 mm ²	LEL 4/3 SCHWARZ	05.561.8753.0	100	LEL 4/3 SCHWARZ	05.561.8753.0	100
7. Cover with warning symbol over 4 blocks		ADF 4/4 GELB	04.343.6153.8	10	ADF 4/4 GELB	04.343.6153.8	10
8. Test plug		ST 2/2,3	Z5.553.2921.0	10	ST 2/2,3	Z5.553.2921.0	10
9. Screwdriver, uninsulated		DIN 5264 B 0,6x3,5	06.502.4000.0	5	DIN 5264 B 0,6x3,5	06.502.4000.0	5
Screwdriver, uninsulated, MINI		DIN 5264 B 0,6x3,5 M	06.502.5000.0	10	DIN 5264 B 0,6x3,5 M	06.502.5000.0	10
Marking accessories see page 76–79							

- Potential distribution with standard cross connector IVB WKF 4...
- Parallel connection of two cross connectors -> double jumpering
- Potential distributions are possible on one or both sides

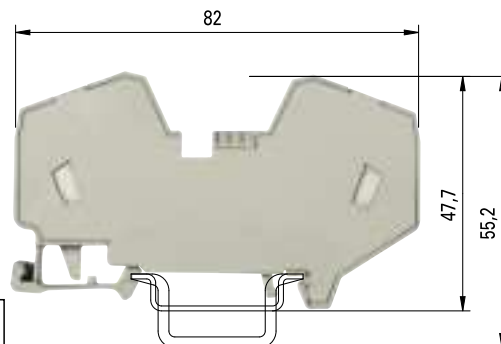

Potential distribution	one side		both sides	
	single	double	single	double
I_{max}	64	76	76	76
I_{Nblock}	32	32	32	32

$$I_{max} = \sum I_n \leq \sum I_{Nblock}$$

WKF 16/35 PV/WKFN

fine-stranded	solid/stranded	V	A
4-16 mm ²	4-16 mm ²	800 V/8 kV/3	76
No. 24-4 AWG		600 V	75
No. 12-4 AWG		600 V	78
4-16 mm ²	4-16 mm ²	690 V	64*
12 mm			15 mm

Type	Part No.	Std. Pack
WKF 16/35 PV/WKFN	56.716.0353.0	20
35x27x7,5 EN 60715	98.300.0000.0	1
35x24x15 EN 60715	98.360.0000.0	1
9708/2 S35	Z5.522.8553.0	100
WEF 1/35	Z5.523.9353.0	100
IVB WKF 4-2	Z7.261.1227.0	10
IVB WKF 4-3	Z7.261.1327.0	10
IVB WKF 4-4	Z7.261.1427.0	10
IVB WKF 4-5	Z7.261.1527.0	10
IVB WKF 4-6	Z7.261.1627.0	10
IVB WKF 4-7	Z7.261.1727.0	20
IVB WKF 4-8	Z7.261.1827.0	20
IVB WKF 4-9	Z7.261.1927.0	20
IVB WKF 4-10	Z7.261.2027.0	20
ADF 16/4 GELB	04.343.6653.8	10
ST 2/2,3	Z5.553.2921.0	10
DIN 5264 B 1,0x5,5	06.502.4200.0	5

* Type-specific output currents upon request

Initiator and actuator blocks with tension spring connection

fasis



System advantages used

For machine and system control wiring, practice-oriented solutions are preferred that are primarily economical and reliable and thus contribute to the system's operational and functional safety.

fasis KOI was designed to connect the great variety of initiators and actuators to central and remote control systems. The initiator and actuator blocks of type WKF 1,5 KOI have, in particular, been conceived for the requirements in machine and system engineering. They facilitate the wiring task through clearly arranged termination points and an easily accessible and operable tension spring technology.

fasis KOI is a compact and efficient wiring system for connection purposes, potential distribution and transmission of signals from initiators and actuators.

- Control-compatible system solutions through accurate tuning of the connection modules' number of poles to the input and output modules of the PLC.
- Flexible fixation through snap-on to the TS35 mounting rail or screw-on of the connection module to the base board.
- Application-specific individual terminal block as a link between initiators, actuators and the PLC.



Economically designed

- Low space requirements due to compact dimensioning of the individual terminal blocks and integration of the potential distribution inside the connection module.
- Efficient installation and start-up of the wiring system by simply fitting the connection module with components, which supersedes additional connection accessories.
- Reduction of the warehousing costs due to a low variety of parts without having to forego flexibility in the application.



Service-friendly operation

- Short maintenance times for modifications of the terminal block assembly by replacing or extending individual blocks without interrupting the power supply of the other initiator and actuator blocks.
- Immediate visual monitoring of the switching states due to integrated light-emitting diodes.
- No maintenance required due to a permanently safe and dynamic terminal block connection using spring clamp technology in a tension spring system.

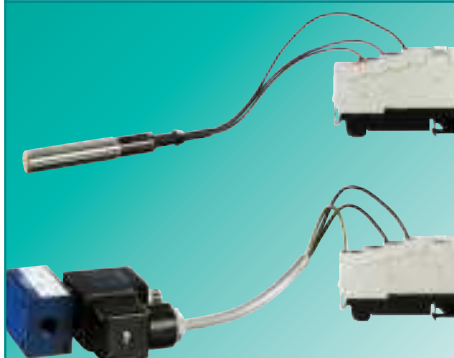

Application-related selection

- Power supply to the connection modules through supply blocks, alternatively with LEDs.
- Potential distribution through connection modules in designs for 9 (1+8) or 18 (2x(1+8)) terminal blocks.
- Initiator blocks, for example for the connection of 3-wire or 4-wire proximity or position switches, alternatively with LEDs.
- Actuator terminals, for example for the connection of magnetic valves.



Connection module

Collect and distribute potentials

- Potential distribution is achieved quickly and safely as soon as the terminal blocks are snapped on.
- Connection rails for the plus, minus and ground or screen potential are each integrated in the connection modules.
- The system does not require any additional cross connectors.



Cover for connection modules

Collect and distribute potentials

- Unused terminal block locations can be closed with connection module covers and thus prevent accidental contact.
- The covers are delivered in 8 pole sets and can be separated individually as required.
- Protection against accidental contact according to IP20 is guaranteed when the covers are snapped on.



Wire entry guides

Connect „small cross sections“ safely

- Wire entry guides prevent the wires from being inserted too deeply (smaller than 1 mm²) and enable an easy, professional and quick installation.
- Ensure the connection of solid and fine-stranded wires smaller than 1 mm².
- Also see the accessories for DIN rail terminal blocks on page 73!



Marking system

All clamping points marked clearly

- Marking tags easily readable even with the wires connected.
- Clear assignment of wire to the termination point while wiring.
- Simplified troubleshooting for servicing.
- Individual marking with the **wiemarc** and **wieplot** marking systems.

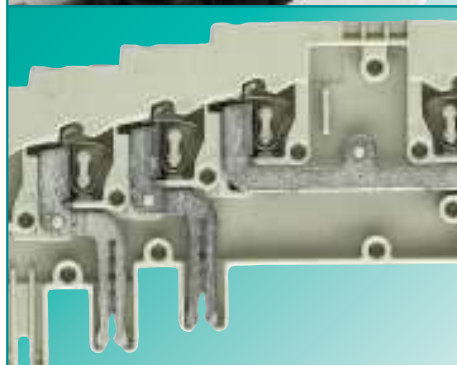

Materials

High-quality materials selected

- Special alloys enable low feed-through resistance and provide a gas-tight contact area:
 - clamping spring: stainless CrNi steel
 - current-carrying bar: tin-plated copper
- Polyamide has excellent electrical, chemical and mechanical characteristics:
 - temperature resistance: up to 120°C
 - creepage resistance: CTI 600
 - flammability class: self-extinguishing, UL94-V2

Initiator and actuator blocks with tension spring connection

fasis

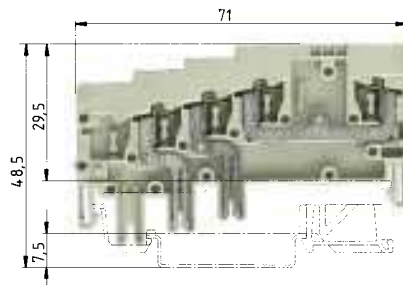

37.702.7453.0
* 65 V/1.5 kV/3



37.702.8453.0
* DC 24 V
same as picture,
but with LED

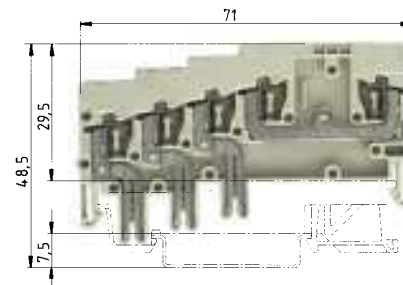

37.702.7553.0
* 65 V/1.5 kV/3

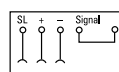

37.702.8553.0
* DC 24 V
same as picture,
but with LED

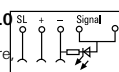

WKF 1,5 KOI 3L...

fine-stranded solid V A
0.13–1.5 mm² 0.13–1.5 mm² * 10

No. 28-16 AWG 65 V 10

5 mm 10 mm



WKF 1,5 KOI 3L/SL...

fine-stranded solid V A
0.13–1.5 mm² 0.13–1.5 mm² * 10

No. 28-16 AWG 65 V 10

5 mm 10 mm



EN 60 947-7-1/DIN VDE 0611 T1

UL ratings field/factory wiring

CSA ratings

Width Wire strip length

Approvals

		Type	Part No.	Std. Pack	Type	Part No.	Std. Pack
Initiator block	gray	WKF 1,5 KOI 3L	37.702.7453.0	50			
Initiator block with LED (PNP)	gray	WKF 1,5 KOI 3L-PGE	37.702.8453.0	50			
Initiator block	gray				WKF 1,5 KOI 3L/SL	37.702.7553.0	50
Initiator block with LED (PNP)	black				WKF 1,5 KOI 3L/SL-PGE	37.702.8553.0	50
Supply block	black						
Supply block with LED	gray						
Actuator block	gray						
Actuator block with LED	gray						
Connection module for 9 blocks	black						
Connection module for 18 blocks	black						
Accessories							
1. Mounting rail 35, 7.5 mm high	L = 2 m	35x27x7,5 EN 60715	98.300.0000.0	1	35x27x7,5 EN 60715	98.300.0000.0	1
Mounting rail 35, 15 mm high	L = 2 m	35x24x15 EN 60715	98.360.0000.0	1	35x24x15 EN 60715	98.360.0000.0	1
2. End clamp TS 35, with screw	8 mm wide	9708/2 S35	Z5.522.8553.0	100	9708/2 S35	Z5.522.8553.0	100
End clamp TS 35, screwless	8 mm wide	WEF 1/35	Z5.523.9353.0	100	WEF 1/35	Z5.523.9353.0	100
3. End plate							
4. Partition plate							
5. Cross connector	2 pole						
insulated	3 pole						
	4 pole						
	5 pole						
	6 pole						
	7 pole						
	8 pole						
	9 pole						
	10 pole						
6. Wire entry guide	0.13–0.2 mm ²	LEL 1,5/1 WEISS	05.562.2453.0	100	LEL 1,5/1 WEISS	05.562.2453.0	100
	0.25–0.5 mm ²	LEL 1,5/2 GRAU	05.562.2553.0	100	LEL 1,5/2 GRAU	05.562.2553.0	100
	0.75–1.0 mm ²	LEL 1,5/3 SCHWARZ	05.562.2653.0	100	LEL 1,5/3 SCHWARZ	05.562.2653.0	100
7. Cover for connection module							
8. Screwdriver, uninsulated		DIN 5264 B 0,6x3,5	06.502.4000.0	5	DIN 5264 B 0,6x3,5	06.502.4000.0	5
Marking accessories see page 76–79							

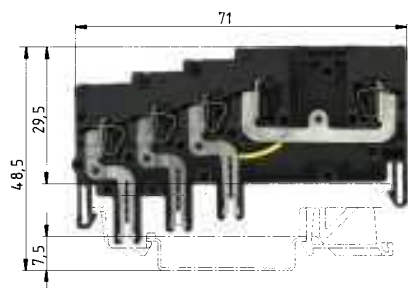

37.702.7753.0
* 65 V/1.5 kV/3

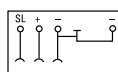

37.702.8753.0
* DC 24 V
same as picture
but with LED

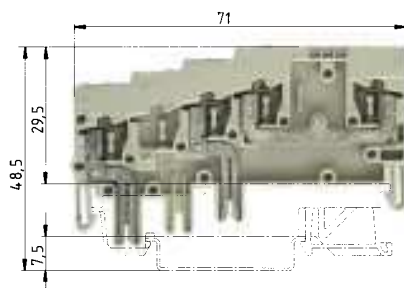
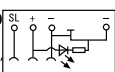

37.702.7653.0
* 65 V/1.5 kV/3

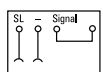

37.702.8653.0
* DC 24 V
same as picture
but with LED

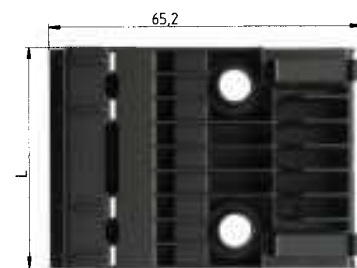

WKF 1,5 KOE...

fine-stranded solid V A
0.13–1.5 mm² 0.13–1.5 mm² * 10

No. 28-16 AWG 65 V 10

5 mm 10 mm



WKF 1,5 KOA 2L...

fine-stranded solid V A
0.13–1.5 mm² 0.13–1.5 mm² * 10

No. 28-16 AWG 65 V 10

5 mm 10 mm



VM WKF ...

V A
* 10
65 V 10

9 pole module
18 pole module

L = 9 x 5 mm + 1.5 mm
L = 18 x 5 mm + 1.5 mm



Type	Part No.	Std. Pack	Type	Part No.	Std. Pack	Type	Part No.	Std. Pack
WKF 1,5 KOE	37.702.7753.0	50	WKF 1,5 KOA 2L	37.702.7653.0	50	VM WKF KD..9	69.700.0953.0	10
WKF 1,5 KOE-PGN	37.702.8753.0	50	WKF 1,5 KOA 2L/SL-PGE	37.702.8653.0	50	VM WKF KD..18	69.700.1853.0	5
35x27x7,5 EN 60715	98.300.0000.0	1	35x27x7,5 EN 60715	98.300.0000.0	1	35x27x7,5 EN 60715	98.300.0000.0	1
35x24x15 EN 60715	98.360.0000.0	1	35x24x15 EN 60715	98.360.0000.0	1	35x24x15 EN 60715	98.360.0000.0	1
9708/2 S35	Z5.522.8553.0	100	9708/2 S35	Z5.522.8553.0	100	9708/2 S35	Z5.522.8553.0	100
WEF 1/35	Z5.523.9353.0	100	WEF 1/35	Z5.523.9353.0	100	WEF 1/35	Z5.523.9353.0	100
LEL 1,5/1 WEISS	05.562.2453.0	100	LEL 1,5/1 WEISS	05.562.2453.0	100	AD VM-1,5/8 SCHWARZ	04.343.8053.0	10
LEL 1,5/2 GRAU	05.562.2553.0	100	LEL 1,5/2 GRAU	05.562.2553.0	100			
LEL 1,5/3 SCHWARZ	05.562.2653.0	100	LEL 1,5/3 SCHWARZ	05.562.2653.0	100			
DIN 5264 B 0,6x3,5	06.502.4000.0	5	DIN 5264 B 0,6x3,5	06.502.4000.0	5			

DIN rail terminal blocks with tension spring and pluggable connections

fasis

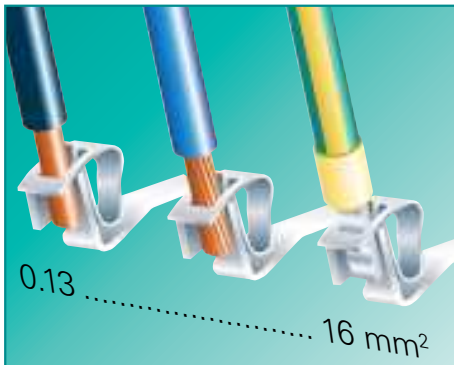

System advantages

- ❑ **Spring clamp technology**
with tension spring connection
- Separation of electrical and mechanical functions

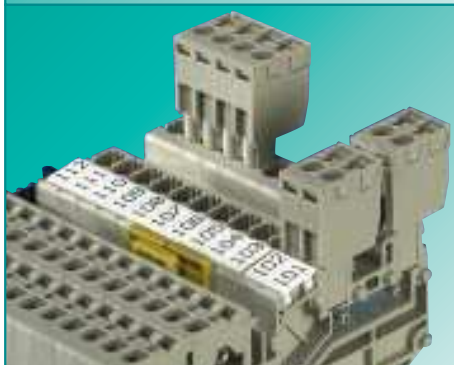

- ❑ **TOP connection**
Wire entry and screwdriver access in same plane
- ❑ **Built-in test points**
- ❑ **Pre-assembled modules**



- ❑ **Pluggable wiring inside the control cabinet**

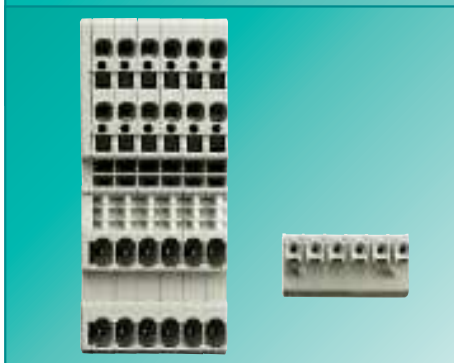
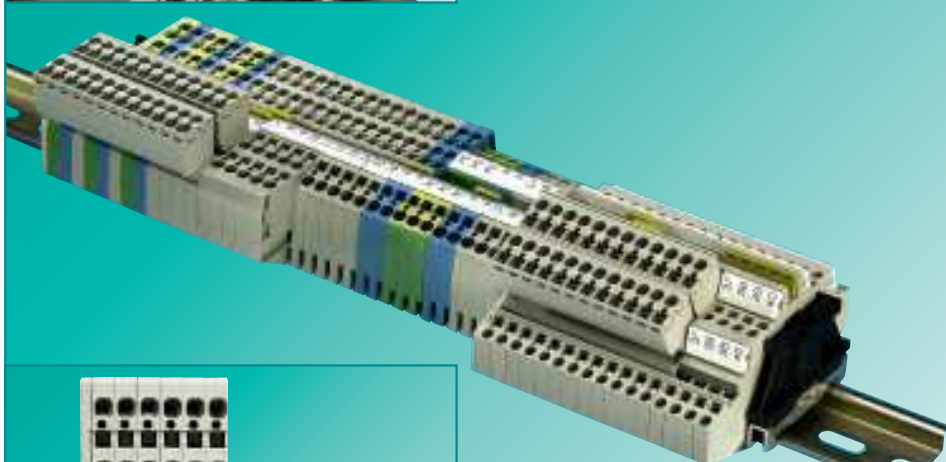

- ❑ Protected against accidental contact
- ❑ Safety through coding

Application advantages

- **Dynamic connections**
Protection of the connection against "cold flow" and creepage
- **Pre-programmed clamping force**
The clamping force required to connect the wire, is created by the spring elements of the clamp
- **Durable and maintenance-free electrical connection**
according to EN 60947-7-1
- **Clear wiring**
In small confined spaces
- **Test points for test plugs** up to $\varnothing 2.3$ mm on all clamping points, without having to remove the connected wire
- **Reduced downtime** due to quick and easy component replacement
- **Wiring errors reduced to a minimum**
- **Cost reduction** in assembly on site

- **Time saving due to pluggable accessories**

- **Flexible potential distribution** through terminal strip

- ❑ Two versions of DIN rail terminal blocks:
 - WKF 2.5/D2/8113... with 2 inputs and 2 outputs on one potential, only 5 mm wide
 - WKF 2.5 E/8113/35 with 2 input and 2 outputs with different potentials in double-tier design

- Dead front safety as per IEC 60529 due to shrouded pins on the plug side
- Coding pieces prevent incorrect mating of the pluggable connector



Cross connection

- Jumpering with insulated cross connector IVB WKF 2.5...
- Two-channel system inside the terminal strip enables chained jumpering through cross connectors
- No partition plates required between adjacent cross connectors
- Cross connectors IVB WKF 2.5... can be loaded with the rated current

Wire entry guides

- For the connection of wires with cross sections smaller than 18 AWG we recommend the use of wire entry guides
- Wire entry guides prevent the wires from being inserted beyond the optimal clamping point and ensure a safe and secure connection

Marking accessories

- Single marking tag in 5 mm spacing
- Marking strips (10 tags) to snap on to the terminal blocks
- Tear-off marking strips for 3-digit marking options per block
- Custom marking upon request

Cover with warning symbol

- Cover with warning symbol ADF to snap on to blocks that remain live when the main switch is disconnected (VDE 0113)
- Cover for spring-loaded termination point ADF 2.5/4 GELB
- Cover for PCB connection ADF 8113/10 GELB
- Cover can only be removed with a screwdriver

DQS certificates for all products

- Quality standard as per DIN ISO 9001
- in Development, Production, Assembly
- Continued control of the quality standard by means of regular internal and external quality audits
- Compatible with certificates of other countries:
 - BSI Certificate, Great Britain
 - SQS Certificate, Switzerland
 - Aib-Vincotte Certificate, Belgium
 - ÖQS Certificate, Austria

Material

Metal parts

Special alloys and surface treatments provide low contact resistance and high corrosion resistance

Clamping spring: stainless CrNi steel

Busbar: tin-plated cooper

Insulating material

Polyamide has excellent electrical, chemical and mechanical characteristics

Insulating housing: Polyamide 66/6

Tracking resistance: CTI 600

Flammability class: UL 94 V-0

(see also AT catalog section **facts** & DATA)

Our **wieplan** software helps to plan your DIN rail terminal block assemblies (see AT catalog page 36/37).

Note

The information regarding cross-sectional areas and connection types pertains to wires without ferrules. Ferrules are not necessary for secure connection.

The voltage ratings apply to the terminals in their intended application. When different products are mounted adjacent to each other, the proper isolation distances must be adhered to. For this purpose, **Wieland** offers a large selection of appropriate accessories.

A detailed description of technical data, the standards requirements, and the application conditions can be found in catalog section **facts** & DATA.

DIN rail terminal blocks with tension spring and pluggable connections

fasis

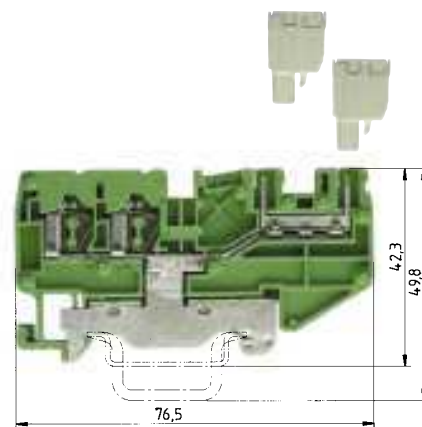
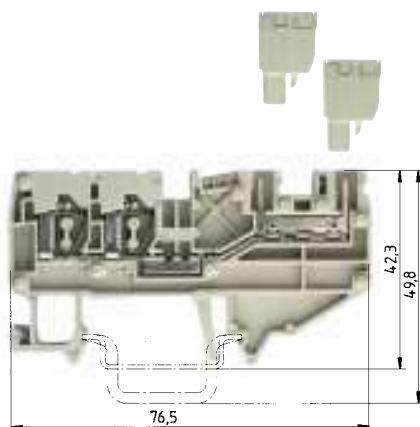

WKF 2,5 D2/8113/35

fine-stranded solid	V	A
0.13–2.5 mm ² 0.13–4 mm ²	250 V/4 kV/3	16
No. 22-12 AWG	300 V	15
No. 24-12 AWG	300 V	15

Wire strip length	5 mm	11 mm

WKF 2,5 D2/8113/SL/35

fine-stranded solid	V	A
0.13–2.5 mm ² 0.13–4 mm ²	250 V/4 kV/3	16
No. 22-12 AWG	300 V	15
No. 24-12 AWG	300 V	15

Wire strip length	5 mm	11 mm

EN 60 947-7-1/DIN VDE 0611 T1

UL ratings field/factory wiring

CSA ratings

Width Wire strip length

Approvals

		Type	Part No.	Std. Pack	Type	Part No.	Std. Pack
Duo feed-through block	gray	WKF 2,5 D2/8113/35	56.703.2053.0	100			
	blue	WKF 2,5 D2/8113/35 BLAU	56.703.2053.6	100			
Duo ground block	yellow/green				WKF 2,5 D2/8113 SL/35	56.703.9253.0	100
Multi-tier block	gray						
Accessories							
1. Mounting rail 35, 7.5 mm high	L = 2 m	35x27x7,5 EN 60715	98.300.0000.0	1	35x27x7,5 EN 60715	98.300.0000.0	1
Mounting rail 35, 15 mm high	L = 2 m	35x24x15 EN 60715	98.360.0000.0	1	35x24x15 EN 60715	98.360.0000.0	1
2. End clamp TS 35, with screw	8 mm wide	9708/2 S35	Z5.522.8553.0	100	9708/2 S35	Z5.522.8553.0	100
End clamp TS 35, screwless	8 mm wide	WEF 1/35	Z5.523.9353.0	100	WEF 1/35	Z5.523.9353.0	100
3. End plate	gray	APF 2,5/D2/8113	07.312.4153.0	10	APF 2,5/D2/8113	07.312.4153.0	10
	blue	APF 2,5/D2/8113	07.312.4153.6	10			
4. Partition plate	gray						
	blue						
5. Cross connector	2 pole	IVB WKF 2,5–2	Z7.280.6227.0	10			
insulated	3 pole	IVB WKF 2,5–3	Z7.280.6327.0	10			
	4 pole	IVB WKF 2,5–4	Z7.280.6427.0	10			
	5 pole	IVB WKF 2,5–5	Z7.280.6527.0	10			
	6 pole	IVB WKF 2,5–6	Z7.280.6627.0	10			
	7 pole	IVB WKF 2,5–7	Z7.280.6727.0	20			
	8 pole	IVB WKF 2,5–8	Z7.280.6827.0	20			
	9 pole	IVB WKF 2,5–9	Z7.280.6927.0	20			
	10 pole	IVB WKF 2,5–10	Z7.280.7027.0	20			
6. Wire entry guide	0.13–0.2 mm ²	LEL 2,5/1 WEISS	05.561.6553.0	100	LEL 2,5/1 WEISS	05.561.6553.0	100
	0.25–0.5 mm ²	LEL 2,5/2 GRAU	05.561.6653.0	100	LEL 2,5/2 GRAU	05.561.6653.0	100
	0.75–1.0 mm ²	LEL 2,5/3 SCHWARZ	05.561.6753.0	100	LEL 2,5/3 SCHWARZ	05.561.6753.0	100
7. Cover with warning symbol over 4 blocks		ADF 2,5/4 GELB	04.343.6053.8	10	ADF 2,5/4 GELB	04.343.6053.8	10
Cover with warning symbol over 4 poles		AD 8113/4 GELB	04.343.6853.8	10	AD 8113/4 GELB	04.343.6853.8	10
8. Screwdriver, uninsulated		DIN 5264 B 0,6x3,5	06.502.4000.0	5	DIN 5264 B 0,6x3,5	06.502.4000.0	5
9. Coding strip			05.561.0053.0	100		05.561.0053.0	100
Marking accessories see page 76–79							

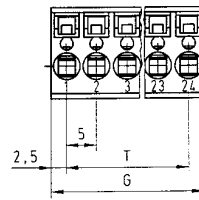
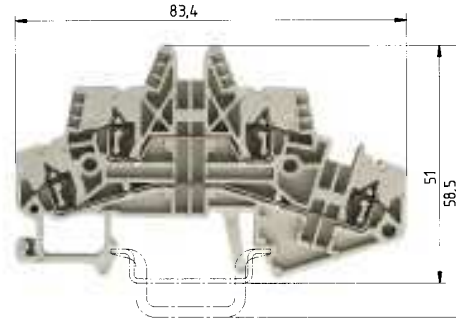
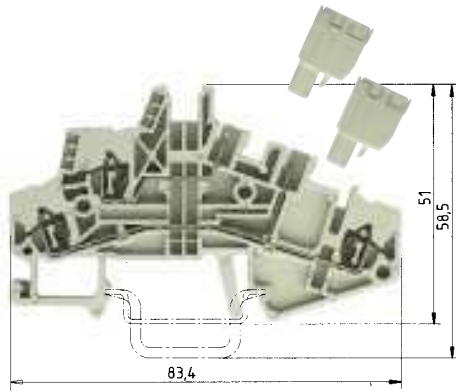

Rated voltages:
VDE 0110/01.89
250 V/4 kV/3 –
Overvoltage category III
400 V/4 kV/2 –
Overvoltage category II
1000 V/4 kV/1 –
Overvoltage category I

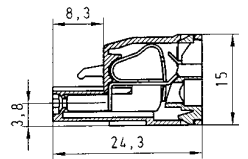

WKF 1,5 E/8113/35

fine-stranded solid V A
0.13–1.5 mm² 0.13–2.5 mm² 250 V/4 kV/3 16
No. 22-14
No. 24-14

5 mm 8 mm

WKF 1,5 E/35

fine-stranded solid V A
0.13–1.5 mm² 0.13–2.5 mm² 400 V/6 kV/3 17,5
No. 30-14 AWG 300 V 15 A
No. 30-14 AWG 600 V 15 A

5 mm 8 mm

Typ 8113 BFK

fine-stranded solid V A
0.13–2.5 mm² 0.13–4 mm² 12
No. 22-12 AWG 300 V 12 A

5 mm 9 mm

Type	Part No.	Std. Pack	Type	Part No.	Std. Pack	Std. Pack	G	T	Pole	Part No.
						5 mm spacing				
						unmarked				
						100	10,00	5,00	2	25.920.3253.0
						100	15,00	10,00	3	25.920.3353.0
WKF 1,5 E/8113/35	56.702.2053.0	100	WKF 1,5 E/35	56.702.7053.0	100	50	20,00	15,00	4	25.920.3453.0
						50	25,00	20,00	5	25.920.3553.0
						50	30,00	25,00	6	25.920.3653.0
35x27x7,5 EN 60715	98.300.0000.0	1	35x27x7,5 EN 60715	98.300.0000.0	1	50	35,00	30,00	7	25.920.3753.0
35x24x15 EN 60715	98.360.0000.0	1	35x24x15 EN 60715	98.360.0000.0	1	50	40,00	35,00	8	25.920.3853.0
9708/2 S35	Z5.522.8553.0	100	9708/2 S35	Z5.522.8553.0	100	50	45,00	40,00	9	25.920.3953.0
WEF 1/35	Z5.523.9353.0	100	WEF 1/35	Z5.523.9353.0	100	50	50,00	45,00	10	25.920.4053.0
APF 1,5/E/8113	07.312.4753.0	10	APF 1,5 E	07.312.3553.0	10	50	55,00	50,00	11	25.920.4153.0
						50	60,00	55,00	12	25.920.4253.0
			TWF 1,5 E	07.312.3653.0	10	50	65,00	60,00	13	25.920.4353.0
						50	70,00	65,00	14	25.920.4453.0
IVB WKF 2,5–2	Z7.280.6227.0	10	IVB WKF 2,5–2	Z7.280.6227.0	10	50	75,00	70,00	15	25.920.4553.0
IVB WKF 2,5–3	Z7.280.6327.0	10	IVB WKF 2,5–3	Z7.280.6327.0	10	50	80,00	75,00	16	25.920.4653.0
IVB WKF 2,5–4	Z7.280.6427.0	10	IVB WKF 2,5–4	Z7.280.6427.0	10	marked				
IVB WKF 2,5–5	Z7.280.6527.0	10	IVB WKF 2,5–5	Z7.280.6527.0	10	100	10,00	5,00	2	25.920.0253.0
IVB WKF 2,5–6	Z7.280.6627.0	10	IVB WKF 2,5–6	Z7.280.6627.0	10	100	15,00	10,00	3	25.920.0353.0
IVB WKF 2,5–7	Z7.280.6727.0	20	IVB WKF 2,5–7	Z7.280.6727.0	20	50	20,00	15,00	4	25.920.0453.0
IVB WKF 2,5–8	Z7.280.6827.0	20	IVB WKF 2,5–8	Z7.280.6827.0	20	50	25,00	20,00	5	25.920.0553.0
IVB WKF 2,5–9	Z7.280.6927.0	20	IVB WKF 2,5–9	Z7.280.6927.0	20	50	30,00	25,00	6	25.920.0653.0
IVB WKF 2,5–10	Z7.280.7027.0	20	IVB WKF 2,5–10	Z7.280.7027.0	20	50	35,00	30,00	7	25.920.0753.0
LEL 1,5/1 WEISS	05.562.2453.0	100	LEL 1,5/1 WEISS	05.562.2453.0	100	50	40,00	35,00	8	25.920.0853.0
LEL 1,5/2 GRAU	05.562.2553.0	100	LEL 1,5/2 GRAU	05.562.2553.0	100	50	45,00	40,00	9	25.920.0953.0
LEL 1,5/3 SCHWARZ	05.562.2653.0	100	LEL 1,5/3 SCHWARZ	05.562.2653.0	100	50	50,00	45,00	10	25.920.1053.0
ADF 1,5/4 GELB	04.343.8353.8	10	ADF 1,5/4 GELB	04.343.8353.8	10	50	55,00	50,00	11	25.920.1153.0
AD 8113/4 GELB	04.343.6853.8	10	DIN 5264 B 0,6x3,5	06.502.4000.0	5	50	60,00	55,00	12	25.920.1253.0
DIN 5264 B 0,6x3,5	06.502.4000.0	5	DIN 5264 B 0,6x3,5 M	06.502.5000.0	10	50	65,00	60,00	13	25.920.1353.0
	05.561.0053.0	100				50	70,00	65,00	14	25.920.1453.0
						50	75,00	70,00	15	25.920.1553.0
						50	80,00	75,00	16	25.920.1653.0
						17- to 24- pole configurations upon request				
						Accessories: coding piece 05.561.9153.0				

Motor connection block with tension spring connection

fasis

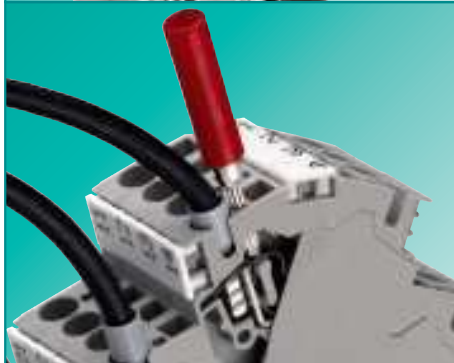

We have designed the motor connection block for a practice-oriented wiring of three-phase field devices. This is especially exhibited in the dimensioning of the rated values such as the high rated voltage of 800 V (EN 60947-7).

The connector can therefore also be used in 690 V networks, for example as connector for activating generators or AC motors up to 15 kW.

For the 4 wiring tiers of the motor connection block (3 feed-through potentials and one ground connection) the space requirements on the mounting rail are reduced to only 6 mm.

The motor connection block is a "space saver" providing you with many connection options.

mark

Clear marking of all clamping points

Benefits:

- Group marking in the center of the block is possible
- Clear assignment of wire to termination point on wiring
- Individual marking with the **wiemarc** marking system

clamp

Flexible and universal connecting

Benefits:

- Connection of solid, stranded and fine-stranded wires between 0.13 and 6 mm²
- Connection of fine-stranded wires with ferrule between 0.5 and 4 mm²

save

Use and save

Benefits:

- Snap on and the ground connection to the mounting rail is made
- Compact: 6 mm required on the mounting rail for one motor
- Design: closed insulated housing, no accessories

test

Measuring voltage with an integrated testing facility

Benefits:

- Testing at full wiring
- Testing directly at the current carrying bar

DIN rail terminal blocks with tension spring connection

fasis MINI



Solutions for applications in confined spaces



Application-related selection



Combined individually



Permanent electrical connection

With our DIN rail terminal block system **fasis** MINI we focus on the application's size and flexibility. **fasis** MINI is a range of DIN rail terminal blocks in tension spring technology designed for installation in confined spaces.

The portfolio comprises ground blocks and feed-through blocks in various colors with 2 or 4 connections per potential.

The potential in the WKFM 2,5 terminal block series can be distributed, modified and extended quickly, flexibly and without problem by using cross connectors.

For installation on TS 35 and TS 15 mounting rails, on mounting boards or inside universal terminal boxes we provide various designs with latching foot, latching pin or screw flange.

- Space-saving miniature terminal blocks in many designs for installation inside universal terminal boxes, motors and applications with low space requirements.
- Easy wiring through user-friendly entry guides for screwdrivers from the top.
- Marking tags easily readable even with the wires connected.
- Individual planning and marking using **wieplan** and **wiemarc**.

- Miniature terminal blocks with latching foot for direct installation on the mounting board.
- Miniature terminal blocks with flange for direct screw fixation on the mounting board.
- Miniature terminal blocks for installation on TS 15 or TS 35 mounting rails.

- DIN rail terminal blocks of the **fasis** MINI series are available in 2 and 4 pole configurations.
- **fasis** MINI blocks can be chained individually even without mounting rails by using the integrated latching pins.
- The various potentials and terminal blocks are visually distinguished by various color variations.
- Individual marking using marking tags or customized printing of the terminal blocks.

- The tension spring system provides a dynamic clamping connection. Load-controlled and thermal cold flow properties of the connected wires are balanced.
- Maintenance-free and gas-tight electrical connection as specified by the approvals. Customized layouts can be created individually.
- Separation of electrical and mechanical functions.

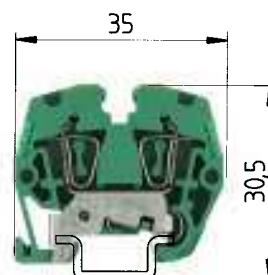
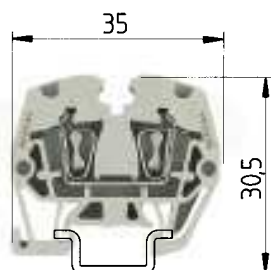

0344 Ex II 2GD

Ex e II

EN 60 947-7-1

UL ratings field/factory wiring

CSA ratings

KEMA 03 ATEX 2071 U¹⁾ EN 60079-0/EN 60079-7

Width Wire strip length

Approvals

WKMF 2,5/15

fine-stranded solid	V	A
0.13–2.5 mm ² 0.13–2.5 mm ²	500 V/6 kV/3	24
No. 26-12 AWG	600 V	20
No. 26-12 AWG	300 V	20
0.5–2.5 mm ² 0.5–2.5 mm ²	275 V ^{*)}	19/20 ²⁾
5 mm		10 mm

ATEX

WKMF 2,5 SL/15

fine-stranded solid	V	A
0.13–2.5 mm ² 0.13–2.5 mm ²	500 V/6kV/3 ⁴⁾	3 ³⁾
No. 26-12 AWG	600 V	
No. 26-12 AWG	300 V	
0.5–2.5 mm ² 0.5–2.5 mm ²	*)	
5 mm		10 mm

ATEX

	Type	Part No.	Std. Pack	Type	Part No.	Std. Pack
Feed-through block gray	WKMF 2,5/15	55.703.0053.0	100			
Feed-through block blue	WKMF 2,5/15	55.703.0053.6	100			
Ground block green/yellow				WKMF 2,5 SL/15	55.703.9053.0	100
Accessories						
1. Mounting rail 15, 5.5 mm high L = 2 m	9021/15x5,5 EN 50045	98.090.0015.0	10	9021/15x5,5 EN 50045	98.090.0015.0	10
2. End clamp TS 15, metal 7,5 mm wide	9222	Z5.522.5010.0	100	9222	Z5.522.5010.0	100
End clamp TS 15, polyamide 7,5 mm wide	9208 S 15	Z5.522.7553.0	100	9208 S 15	Z5.522.7553.0	100
3. End plate 1.5 mm wide gray	APMF 2,5 /15	07.312.5953.0	10	APMF 2,5 /15	07.312.5953.0	10
1.5 mm wide blue						
1.5 mm wide green						
4. Partition plate 1.5 mm wide gray						
1.5 mm wide blue						
5. Cross connector 2 pole	IVB WKMF 2,5–2	Z7.260.0229.0	10			
insulated 3 pole	IVB WKMF 2,5–3	Z7.260.0329.0	10			
4 pole	IVB WKMF 2,5–4	Z7.260.0429.0	10			
5 pole	IVB WKMF 2,5–5	Z7.260.0529.0	10			
6 pole	IVB WKMF 2,5–6	Z7.260.0629.0	10			
7 pole	IVB WKMF 2,5–7	Z7.260.0729.0	10			
8 pole	IVB WKMF 2,5–8	Z7.260.0829.0	10			
9 pole	IVB WKMF 2,5–9	Z7.260.0929.0	10			
10 pole	IVB WKMF 2,5–10	Z7.260.1029.0	10			
50 pole	IVB WKMF 2,5 M50	Z7.260.0029.0	10			
6. Wire entry guide 0.13–0.2 mm ²						
0.25–0.5 mm ²						
0.75–1.0 mm ²						
7. Cover with warning symbol for 4 terminals						
8. Screwdriver, uninsulated	DIN 5264 B 0,6x3,5	06.502.4000.0	5	DIN 5264 B 0,6x3,5	06.502.4000.0	5
Screwdriver, uninsulated, MINI	DIN 5264 B 0,6x3,5 M	06.502.5000.0	10	DIN 5264 B 0,6x3,5 M	06.502.5000.0	10
Marking accessories see page 76–79						

^{*)} For maintaining the proper isolation distances, the open side of feed-through or ground blocks as well as both sides of a jumper are to be covered by partitions.

¹⁾ Please note the mounting instructions in AT catalog.

²⁾ with/without jumper

³⁾ For the current carrying capability of the mounting rail see AT catalog section **facts & DATA**. ⁴⁾ Ratings to adjacent feed-through blocks of the same series and size

Mini terminal blocks with tension spring connection

fasis MINI TS

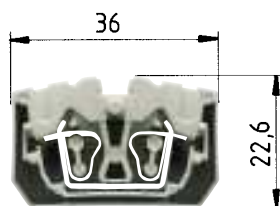

WKF 2,5/M/F



WKF 2,5/M

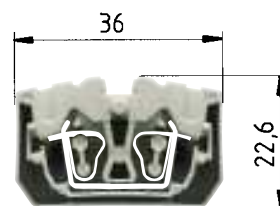

WKF 2,5/MD/F



WKF 2,5/MD

WKF 2,5/M with flange

fine-stranded	solid	V	A
0.13–2.5 mm ²	0.13–4 mm ²	800 V	24

WKF 2,5/MD with flange

fine-stranded	solid	V	A
0.13–2.5 mm ²	0.13–4 mm ²	800 V	24

EN 60 947-7-1:2002

UL ratings
CSA ratings

Width
Approvals

field/factory wiring

Wire strip length

5 mm



11 mm

10 mm



11 mm

			Type	Part No.	Std. Pack	Type	Part No.	Std. Pack
Feed-through block	unmarked	gray	WKF 2,5/M	37.703.0553.0	100			
Feed-through block	unmarked	blue	WKF 2,5/M BLAU	37.703.0553.6	100			
Feed-through block	unmarked	orange	WKF 2,5/M ORANGE	37.703.0553.9	100			
Feed-through block	with flange	gray	WKF 2,5/M/F	39.703.0153.0	100			
Feed-through block	with flange	blue	WKF 2,5/M/F BLAU	39.703.0153.6	100			
Feed-through block	with flange	orange	WKF 2,5/M/F ORANGE	39.703.0153.9	100			
Duo feed-through block	unmarked	gray				WKF 2,5/MD	37.703.1053.0	100
Duo feed-through block	unmarked	blue				WKF 2,5/MD BLAU	37.703.1053.6	100
Duo feed-through block	unmarked	orange				WKF 2,5/MD ORANGE	37.703.1053.9	100
Duo feed-through block	with flange	gray				WKF 2,5/MD/F	39.703.0253.0	100
Duo feed-through block	with flange	blue				WKF 2,5/MD/F BLAU	39.703.0253.6	100
Duo feed-through block	with flange	orange				WKF 2,5/MD/F ORANGE	39.703.0253.9	100
Accessories								
1. End plate with flange on the right		gray	APF 2,5/M.../F/R	07.312.3153.0	10	APF 2,5/M.../F/R	07.312.3153.0	10
End plate with flange on the right		blue	APF 2,5/M.../F/R BLAU	07.312.3153.6	10	APF 2,5/M.../F/R BLAU	07.312.3153.6	10
End plate with flange on the right		orange	APF 2,5/M.../F/R ORANGE	07.312.3153.9	10	APF 2,5/M.../F/R ORANGE	07.312.3153.9	10
2. Wire entry guide	0.13–0.2 mm ²		LEL 2,5/1 WEISS	05.561.6553.0	100	LEL 2,5/1 WEISS	05.561.6553.0	100
	0.25–0.5 mm ²		LEL 2,5/2 GRAU	05.561.6653.0	100	LEL 2,5/2 GRAU	05.561.6653.0	100
	0.75–1.0 mm ²		LEL 2,5/3 SCHWARZ	05.561.6753.0	100	LEL 2,5/3 SCHWARZ	05.561.6753.0	100
3. Cross connector, insulated		2 pole		05.902.3500.0	10		05.902.3500.0	10
4. Marking strip,	unmarked	(4 x 22 pcs.)		04.244.0053.0	5		04.244.0053.0	5
	marked	(1–11)		04.844.2053.0	5		04.844.2053.0	5
	marked	(12–55)		04.844.2153.0	5		04.844.2153.0	5
	marked	(56–99)		04.844.2253.0	5		04.844.2253.0	5
5. Screwdriver, uninsulated			DIN 5264 B 0,6 x 3,5	06.502.4000.0	5	DIN 5264 B 0,6 x 3,5	06.502.4000.0	5
Marking accessories see page 76–79								

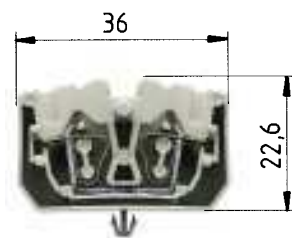

Mounting hole: Ø 3,5 mm
Plate thickness: 0,6–1,2 mm

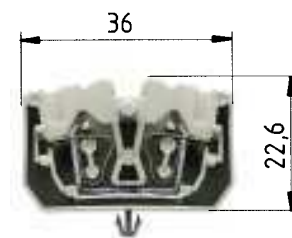

Mounting hole: Ø 3,5 mm
Plate thickness: 0,6–1,2 mm

WKF 2,5/M/R with mounting foot

fine-stranded	solid	V	A
0.13–2.5 mm ²	0.13–4 mm ²	800 V	24

WKF 2,5/MD/R with mounting foot

fine-stranded	solid	V	A
0.13–2.5 mm ²	0.13–4 mm ²	800 V	24

EN 60 947-7-1:2002

UL ratings

CSA ratings

Width

Approvals

field/factory wiring

Wire strip length

5 mm



11 mm

10 mm

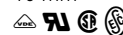

11 mm

			Type	Part No.	Std. Pack			
Feed-through block	unmarked	gray	WKF 2,5/M/R	38.703.0553.0	100			
Feed-through block	unmarked	blue	WKF 2,5/M/R BLAU	38.703.0553.6	100			
Feed-through block	unmarked	orange	WKF 2,5/M/R ORANGE	38.703.0553.9	100			
Duo feed-through block	unmarked	gray				WKF 2,5/MD/R	38.703.1053.0	100
Duo feed-through block	unmarked	blue				WKF 2,5/MD/R BLAU	38.703.1053.6	100
Duo feed-through block	unmarked	orange				WKF 2,5/MD/R ORANGE	38.703.1053.9	100
Accessories								
1. End plate		gray	APF 2,5/M...	07.312.2953.0	10	APF 2,5/M...	07.312.2953.0	10
End plate		blue	APF 2,5/M... BLAU	07.312.2953.6	10	APF 2,5/M... BLAU	07.312.2953.6	10
End plate		orange	APF 2,5/M... ORANGE	07.312.2953.9	10	APF 2,5/M... ORANGE	07.312.2953.9	10
2. Wire entry guide		0.13–0.2 mm ²	LEL 2,5/1 WEISS	05.561.6553.0	100	LEL 2,5/1 WEISS	05.561.6553.0	100
		0.25–0.5 mm ²	LEL 2,5/2 GRAU	05.561.6653.0	100	LEL 2,5/2 GRAU	05.561.6653.0	100
		0.75–1.0 mm ²	LEL 2,5/3 SCHWARZ	05.561.6753.0	100	LEL 2,5/3 SCHWARZ	05.561.6753.0	100
3. Cross connector, insulated		2 pole		05.902.3500.0	10		05.902.3500.0	10
4. Marking strip,	unmarked	(4 x 22 pcs.)		04.244.0053.0	5		04.244.0053.0	5
	marked	(1–11)		04.844.2053.0	5		04.844.2053.0	5
	marked	(12–55)		04.844.2153.0	5		04.844.2153.0	5
	marked	(56–99)		04.844.2253.0	5		04.844.2253.0	5
5. Screwdriver, uninsulated			DIN 5264 B 0,6 x 3,5	06.502.4000.0	5	DIN 5264 B 0,6 x 3,5	06.502.4000.0	5

Mini terminal blocks with tension spring connection

fasis MINI TS

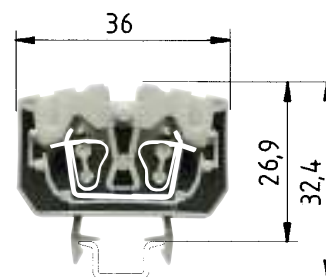
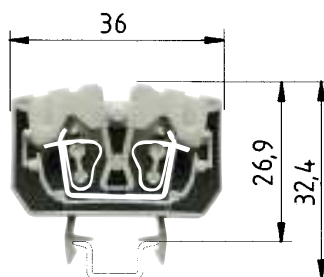

WKF 2,5/M/15

fine-stranded solid V A
0.13–2.5 mm² 0.13–4 mm² 800 V 24

WKF 2,5/MD/15

fine-stranded solid V A
0.13–2.5 mm² 0.13–4 mm² 800 V 24

EN 60 947-7-1:2002

UL ratings
CSA ratings

Width

Approvals

field/factory wiring

Wire strip length

5 mm

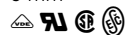

11 mm

10 mm

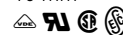

11 mm

			Type	Part No.	Std. Pack	Type	Part No.	Std. Pack
Feed-through block	unmarked	gray	WKF 2,5/M/15	55.703.0553.0	100			
Feed-through block	unmarked	blue	WKF 2,5/M/15 BLAU	55.703.0553.6	100			
Feed-through block	unmarked	orange	WKF 2,5/M/15 ORANGE	55.703.0553.9	100			
Feed-through block	unmarked	green	WKF 2,5/M/15 GRÜN	55.703.0553.7	100			
Duo feed-through block	unmarked	gray				WKF 2,5/MD/15	55.703.1053.0	100
Duo feed-through block	unmarked	blue				WKF 2,5/MD/15 BLAU	55.703.1053.6	100
Duo feed-through block	unmarked	orange				WKF 2,5/MD/15 ORANGE	55.703.1053.9	100
Duo feed-through block	unmarked	green				WKF 2,5/MD/15 GRÜN	55.703.1053.7	100
Zubehör								
1. Mounting rail 15,	5.5 mm high	L = 2 m	9021/15 x 5,5 EN 50045	98.090.0015.0	10	9021/15 x 5,5 EN 50045	98.090.0015.0	10
Mounting rail 35,	7.5 mm high	L = 2 m						
Mounting rail 35,	15 mm high	L = 2 m						
Mounting rail 35,	15 mm high	L = 2 m						
2. End clamp TS 15			9208 S15	Z5.522.7553.0	100	9208 S15	Z5.522.7553.0	100
End clamp TS 15, without screw								
3. End plate	gray		APF 2,5/M...	07.312.2953.0	10	APF 2,5/M...	07.312.2953.0	10
	blue		APF 2,5/M... BLAU	07.312.2953.6	10	APF 2,5/M... BLAU	07.312.2953.6	10
	orange		APF 2,5/M... ORANGE	07.312.2953.9	10	APF 2,5/M... ORANGE	07.312.2953.9	10
4. Wire entry guide	0.13–0.2 mm ²		LEL 2,5/1 WEISS	05.561.6653.0	100	LEL 2,5/1 WEISS	05.561.6653.0	100
	0.25–0.5 mm ²		LEL 2,5/2 GRAU	05.561.6653.0	100	LEL 2,5/2 GRAU	05.561.6653.0	100
	0.75–1.0 mm ²		LEL 2,5/3 SCHWARZ	05.561.6753.0	100	LEL 2,5/3 SCHWARZ	05.561.6753.0	100
5. Cross connector, insulated	2 pole			05.902.3500.0	10		05.902.3500.0	10
6. Marking strip, unmarked	(4 x 22 pcs.)			04.244.0053.0	5		04.244.0053.0	5
marked	(1–11)			04.844.2053.0	5		04.844.2053.0	5
marked	(12–55)			04.844.2153.0	5		04.844.2153.0	5
marked	(56–99)			04.844.2253.0	5		04.844.2253.0	5
yellow, unmarked				04.244.0053.8	5		04.244.0053.8	5
7. Screwdriver, uninsulated			DIN 5264 B 0,6 x 3,5	06.502.4000.0	5	DIN 5264 B 0,6 x 3,5	06.502.4000.0	5
Marking accessories see page 76–79								

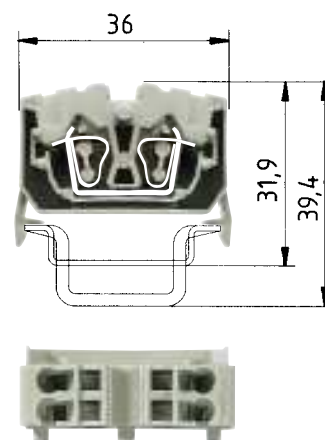
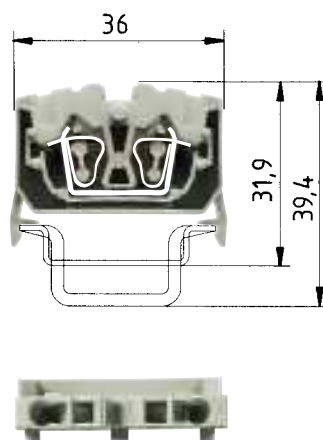

WKF 2,5/M/35

fine-stranded solid V A
0.13–2.5 mm² 0.13–4 mm² 800 V 24

WKF 2,5/MD/35

fine-stranded solid V A
0.13–2.5 mm² 0.13–4 mm² 800 V 24

EN 60 947-7-1:2002

UL ratings
CSA ratings

Width

Approvals

field/factory wiring

Wire strip length

5 mm



11 mm

10 mm



11 mm

			Type	Part No.	Std. Pack	Type	Part No.	Std. Pack
Feed-through block	unmarked	gray	WKF 2,5/M/35	56.703.0553.0	100			
Feed-through block	unmarked	blue	WKF 2,5/M/35 BLAU	56.703.0553.6	100			
Feed-through block	unmarked	orange	WKF 2,5/M/35 ORANGE	56.703.0553.9	100			
Feed-through block	unmarked	green	WKF 2,5/M/35 GRÜN	56.703.0553.7	100			
Duo feed-through block	unmarked	gray				WKF 2,5/MD/35	56.703.1053.0	100
Duo feed-through block	unmarked	blue				WKF 2,5/MD/35 BLAU	56.703.1053.6	100
Duo feed-through block	unmarked	orange				WKF 2,5/MD/35 ORANGE	56.703.1053.9	100
Duo feed-through block	unmarked	green				WKF 2,5/MD/35 GRÜN	56.703.1053.7	100
Zubehör								
1. Mounting rail 15,	5.5 mm high	L = 2 m						
Mounting rail 35,	7.5 mm high	L = 2 m	35x27x7,5 EN 60715	98.300.0000.0	1	35x27x7,5 EN 60715	98.300.0000.0	1
Mounting rail 35,	15 mm high	L = 2 m	35x24x15 EN 60715	98.360.0000.0	1	35x24x15 EN 60715	98.360.0000.0	1
Mounting rail 35,	15 mm high	L = 2 m	35x27x15	98.370.0000.0	1	35x27x15	98.370.0000.0	1
2. End clamp TS 15								
End clamp TS 15, without screw			WEF 1/35	Z5.523.9353.0	100	WEF 1/35	Z5.523.9353.0	100
3. End plate								
	gray		APF 2,5/M... GRAU	07.312.2953.0	10	APF 2,5/M... GRAU	07.312.2953.0	10
	blue		APF 2,5/M... BLAU	07.312.2953.6	10	APF 2,5/M... BLAU	07.312.2953.6	10
	orange		APF 2,5/M... ORANGE	07.312.2953.9	10	APF 2,5/M... ORANGE	07.312.2953.9	10
4. Wire entry guide								
	0.13–0.2 mm ²		LEL 2,5/1 WEISS	05.561.6553.0	100	LEL 2,5/1 WEISS	05.561.6553.0	100
	0.25–0.5 mm ²		LEL 2,5/2 GRAU	05.561.6653.0	100	LEL 2,5/2 GRAU	05.561.6653.0	100
	0.75–1.0 mm ²		LEL 2,5/3 SCHWARZ	05.561.6753.0	100	LEL 2,5/3 SCHWARZ	05.561.6753.0	100
5. Cross connector, insulated		2 pole						
				05.902.3500.0	10		05.902.3500.0	10
6. Marking strip, unmarked		(4 x 22 pcs.)		04.244.0053.0	5		04.244.0053.0	5
marked		(1–11)		04.844.2053.0	5		04.844.2053.0	5
marked		(12–55)		04.844.2153.0	5		04.844.2153.0	5
marked		(56–99)		04.844.2253.0	5		04.844.2253.0	5
yellow, unmarked				04.244.0053.8	5		04.244.0053.8	5
7. Screwdriver, uninsulated			DIN 5264 B 0,6 x 3,5	06.502.4000.0	5	DIN 5264 B 0,6 x 3,5	06.502.4000.0	5

Accessories for DIN rail terminal blocks

fasis

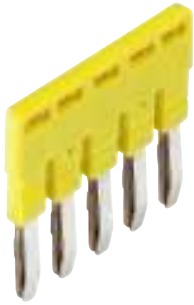

**Cross connector
for feed-through blocks**



**Notching tool
for cross connectors**



**Test plug with spring clamp connection
for WKF/WKC terminal blocks**

PSWKC/F

solid	fine-stranded	V	A
0.13–1.5 mm ²	0.13–1.5 mm ²	400 V	13,5
*5 mm/6 mm			8 mm

Type	Part No.	Std. Pack	Type	Part No.	Std. Pack	Type	Part No.	Std. Pack
1.5 mm², 4 mm wide			1.5 mm², 4 mm wide					
IVB WKF 1,5-2	Z7.260.0227.0	10	AKW /A	95.300.0500.0	1			
IVB WKF 1,5-3	Z7.268.0327.0	10						
IVB WKF 1,5-4	Z7.268.0427.0	10						
IVB WKF 1,5-5	Z7.268.0527.0	10						
IVB WKF 1,5-10	Z7.268.1027.0	10						
IVB WKF 1,5-20	Z7.268.2027.0	10						
2.5 mm², 5 mm wide			2.5 mm², 5 mm wide			2.5 mm², 5 mm wide		
IVB WKF 2,5-2	Z7.280.6227.0	10	AKW /A	95.300.0500.0	1	Test plug PSWKC/F	Z1.299.9753.0	10
IVB WKF 2,5-3	Z7.280.6327.0	10				Blind piece	01.299.9753.0	10
IVB WKF 2,5-4	Z7.280.6427.0	10	Jumping cross connectors			End plate ZP/AP PS	07.312.6053.0	10
IVB WKF 2,5-5	Z7.280.6527.0	10	3 pole 1-3	99.013.9999.9	10			
IVB WKF 2,5-6	Z7.280.6627.0	10	4 pole 1-4	99.014.9999.9	10			
IVB WKF 2,5-7	Z7.280.6727.0	20	5 pole 1-5	99.015.9999.9	10			
IVB WKF 2,5-8	Z7.280.6827.0	20	5 pole 1 to 3 to 5	99.031.9999.9	10			
IVB WKF 2,5-9	Z7.280.6927.0	20	7 pole 1 to 3, 5 and 7	99.032.9999.9	10			
IVB WKF 2,5-10	Z7.280.7027.0	20	9 pole; 1 to 3, 5, 7 and 9	99.033.9999.9	10			
IVB WKF-V	Z7.261.1127.0	10	11 pole; 1 to 3, 5, 7, 9 u. 11	99.034.9999.9	10			
			Additional combinations upon request		10			
4 mm², 6 mm wide			4 mm², 6 mm wide			4 mm², 6 mm wide		
IVB WKF 4-2	Z7.261.1227.0	10	AKW /A	95.300.0500.0	1	Test plug PSWKC/F	Z1.299.9753.0	10
IVB WKF 4-3	Z7.261.1327.0	10				Blind piece	01.299.9753.0	10
IVB WKF 4-4	Z7.261.1427.0	10				End plate ZP/AP PS	07.312.6053.0	10
IVB WKF 4-5	Z7.261.1527.0	10						
IVB WKF 4-6	Z7.261.1627.0	10	Please note the instructions for jumping cross connectors on page 11!			* For 6 mm spacings a ZP/AP PS is snapped on behind each test plug or blind piece.		
IVB WKF 4-7	Z7.261.1727.0	10						
IVB WKF 4-8	Z7.261.1827.0	10						
IVB WKF 4-9	Z7.261.1927.0	10						
IVB WKF 4-10	Z7.261.2027.0	10						
6 mm², 8 mm wide								
IVB WKF 6-2	Z7.282.5227.0	10						
IVB WKF 6-5	Z7.282.5527.0	10						
10 mm², 10 mm wide								
IVB WKF 10-2	Z7.283.8227.0	10						
16 mm², 12 mm wide								
IVB WKF 16-2	Z7.284.4227.0	10						
IVB WKF 16R10-2	Z7.284.4327.0	10						
35 mm², 16 mm wide								
IVB WKF 35-2	Z7.285.6227.0	10						
IVB WKF 35R10-2	Z7.285.6427.0	10						
IVB WKF 35R16-2	Z7.285.6527.0	10						



Cover with warning symbol over 4 blocks



Wire entry guides

for conductors with cross sections smaller than 1 mm²



Screwdrivers as operating tools

Type	Part No.	Std. Pack	Type	Part No.	Std. Pack	Type	Part No.	Std. Pack
1.5 mm², 4 mm wide			1.5 mm², 4 mm wide			1.5 mm², 4 mm wide		
ADF 1,5/5 GELB	04.343.6953.8	10	LEL 1,5/1 WEISS	05.564.4253.0	10	Uninsulated, long and straight		
			for 0.13–0.2 mm ² wires			DIN 5264 B 0,4x2,5	06.502.4300.0	10
			LEL 1,5/2 GRAU	05.564.4253.0	10			
			for 0.25–0.5 mm ² wires					
2.5 mm², 5 mm wide			2.5 mm², 5 mm wide			2.5 mm², 5 mm wide		
ADFN 2,5/4 GELB	04.343.8353.8	10	LELN 2,5/1 WEISS	05.564.3753.0	100	Uninsulated, long and straight		
			for 0.13–0.2 mm ² wires			DIN 5264 B 0,6x3,5	06.502.4000.0	10
			LELN 2,5/1 GRAU	05.564.3853.0	100	Uninsulated, short and straight		
			for 0.25–0.5 mm ² wires			DIN 5264 B 0,6x3,5 M	06.502.5000.0	10
			LELN 2,5/1 SCHWARZ	05.564.3953.0	100	Uninsulated, long and angled		
			for 0.75–1.0 mm ² wires			DIN 5264 B 0,6x3,5 W	05.502.4100.0	10
						Uninsulated, short and angled		
						DIN 5264 B 0,6x3,5 MW	05.502.4000.0	10
4 mm², 6 mm wide			4 mm², 6 mm wide			4 mm², 6 mm wide		
ADF 4/4 GELB	04.343.6153.8	10	LEL 4/1 WEISS	05.561.8553.0	100	Uninsulated, long and straight		
			for 0.13–0.2 mm ² wires			DIN 5264 B 0,6x3,5	06.502.4000.0	10
			LEL 4/2 GRAU	05.561.8653.0	100	Uninsulated, short and straight		
			for 0.25–0.5 mm ² wires			DIN 5264 B 0,6x3,5 M	06.502.5000.0	10
			LEL 4/3 SCHWARZ	05.561.8753.0	100	Uninsulated, long and angled		
			for 0.75–1.0 mm ² wires			DIN 5264 B 0,6x3,5 W	05.502.4100.0	10
						Uninsulated, short and angled		
						DIN 5264 B 0,6x3,5 MW	05.502.4000.0	10
6 mm², 8 mm wide			6 mm², 8 mm wide			6 mm², 8 mm wide		
ADF 6/4 GELB	04.343.6253.8	10				DIN 5264 B 0,6x4	06.502.4100.0	5
10 mm², 10 mm wide			10 mm², 10 mm wide			10 mm², 10 mm wide		
ADF 10/4 GELB	04.343.6453.8	10				DIN 5264 B 0,6x4	06.502.4100.0	5
16 mm², 12 mm wide			16 mm², 12 mm wide			16 mm², 12 mm wide		
ADF 16/4 GELB	04.343.6653.8	10				DIN 5264 B 1x5,5	06.502.4200.0	5
35 mm², 16 mm wide			35 mm², 16 mm wide			35 mm², 16 mm wide		
ADF 35/5 GELB	04.343.9253.8	10				DIN 5264 B 1x5,5	06.502.4200.0	5

Configuration and marking systems for DIN rail terminal blocks



Configuration software *wieplan*

Marking computer *marcom 2*

Marking software *wiemarc*

Type	Part No.	Std. Pack	Type	Part No.	Std. Pack	Type	Part No.	Std. Pack
wieplan CD	95.502.1000.0	1	marcom 2	95.502.0000.0	1	wiemarc CD	95.502.0501.0	1
Contents:			Contents:			Contents:		
CD with cover			Marking computer in case			CD with cover		
			European power supply unit					
			Power Pack					
			Data cassette with job memory					
			Marking tag carrier					
			Plotter pen, 0.25 mm					
			Cleaning set					
Description:			Description:			Description		
<i>wieplan</i> is a software used to configure, document and order DIN rail terminal block assemblies. The intuitive user interface makes working with <i>wieplan</i> as easy as child's play.			<i>wieland marcom 2</i> is a freely programmable marking computer for DIN rail terminal blocks, pluggable connectors, switching devices and cables. The computer provides of a large number of fonts, with numerical and alphanumerical characters and symbols. <i>marcom 2</i> is portable and can be used at any location; it can be operated either using the mains or batteries.			<i>wiemarc</i> is a Windows® based plotter software for customized marking using the <i>wieplot</i> 500. plotter system. Both the Wieland standard marking system and marking tags and labels of other suppliers can be marked easily. The <i>wiemarc</i> software version 4.0 provides the option of connecting to the <i>wieplot</i> 500 E-UNIT engraving system.		
<i>wieplan</i> enables data exchange through CAE systems:								
– EPLAN 5								
– EPLAN Electric P8								
System requirements:			Technical data:			System requirements:		
Pentium II PC or compatible, min. 200 MHz			Operator panel: 190 mm x 45 mm			Pentium II PC or compatible, min. 200 MHz		
64 Mbyte RAM			Resolution: 0.01 mm			64 Mbyte RAM		
CD-ROM drive			Power supply unit: 50/60 Hz, 100–230 V			CD-ROM drive		
VGA graphics adapter and monitor			Output voltage: 9,5 V (150 mV/1.4 VA)			VGA graphics adapter and monitor		
			14 V (450 mA/6.3 VA)					
<i>wieplan</i> supports: Windows 98®			Replaceable battery: 16.8 V (14 NiCd-Zellen)			<i>wieplan</i> supports: Windows 98®		
Windows 2000®			Dimensions: 380 mm x 190 mm x 63 mm			Windows 2000®		
Windows NT®			Weight: 6.2 kg			Windows NT®		
Windows ME®						Windows ME®		
Windows XP®						Windows XP®		

Marking system for DIN rail terminal blocks with spring clamp connection



Plotter system *wieplot* 500

Ink kit for *wieplot* 500

Engraving unit for *wieplot* 500

Type	Part No.	Std. Pack	Type	Part No.	Std. Pack	Type	Part No.	Std. Pack
Complete package	95.502.0604.0	1	Ink kit	95.502.0610.0	1	wieplot 500 E-UNIT	95.502.0700.0	1
Contents:			Contents:			Contents:		
Plotter <i>wieplot</i> 500			Plotter pen 0.25 mm with ink cartridge			Engraving spindle		
Data cable and manual			Permanent plotter pen 0.3 mm			Engraving head (with fuse and counter bearing)		
4 receptacles for WSB*			Cleaning set			Control unit <i>wieplot</i> VEC 500		
Accessories kit			Plotter pens for <i>wieplot</i> 500 systems:			Vacuum cleaner <i>wieplot</i> VC 500		
Software <i>wiemarc</i>						Connection cables		
						Plotter pen 0.18 mm 95.502.0118.0		
						Plotter pen 0.25 mm 95.502.0125.0		
						Plotter pen 0.35 mm 95.502.0135.0		
						Plotter pen 0.50 mm 95.502.0150.0		
						Plotter pen 0.70 mm 95.502.0170.0		
Description:			Plotter pen 1.00 mm 95.502.0100.0			Description:		
With <i>wiemarc</i> you can create customized marking data on your PC. These can then be output on the <i>wieplot</i> 500 plotter system to various marking plates.			Perm. plotter pen 0.30 mm 95.502.0230.0			The <i>wieplot</i> 500 E-UNIT engraving unit has been designed for use with the <i>wieplot</i> 500 plotter. The system is set up for engraving multi-layer plastic tags.		
			Perm. plotter pen 0.70 mm 95.502.0270.0			The Plotboard A4 in a 297 x 202 mm format is the receptacle for marking paper sheets and labels and also enables engraving of plastic boards.		
* WSB (= Wieland standard marking system)			Dispos. plotter pen 0.25 mm 95.502.0125.1					
			Dispos. plotter pen 0.35 mm 95.502.0135.1					
			Hand pens 0.25 mm 95.502.0425.0					
			Hand pens 0.35 mm 95.502.0435.0					
			Hand pens 0.50 mm 95.502.0450.0					
			Hand pens 0.70 mm 95.502.0470.0					
Technical data:			Accessories:			Accessories:		
Resolution:	0.01 mm		Ink cartridge P1.0, 5 x 1 ml	95.502.0199.0		Graving tool SET, complete	95.502.0710.0	
Accuracy:	+/- 0.05 mm		Cleaning set	95.502.0198.0		Graving tool 0.2 mm	95.502.0710.2	
Power supply unit:	50/60 Hz, 100–240 V,		Pen cleaner	95.502.0197.0		Graving tool 0.3 mm	95.502.0710.3	
Output voltage:	24 V DC 1.4 A		Dust protection hood	95.502.0612.0		Graving tool 0.4 mm	95.502.0710.4	
Current input:	ca. 0.3 A bei 220 V		Service kit for pen station	95.502.0613.0		Graving tool 0.5 mm	95.502.0710.5	
Approval:	UL-UL1950		Seal inserts kit			Graving tool 0.7 mm	95.502.0710.7	
	CSA 950					Graving tool 1.0 mm	95.502.0711.0	
	VDE EN 60950		Receptacles for Wieland marking plates			Receptacle:		
Radio interf. suppr.:	FCC class B		Receptacle for WSB	95.502.0620.0		Plotboard A4	95.502.0625.0	
	FCC sect. 15 and VDE class B		Receptacle for BZ/WKF 1,5	95.502.0627.0				
Dimensions:	660 mm x 440 mm x 125 mm		Receptacle for BZ/WKF 1,5/10	95.502.0628.0				
Weight:	8 kg		Available on request:					
Interfaces:	USB Level 1.1, parallel		Receptacles for marking systems from competition					
			Use of <i>wiemarc</i> with non-Wieland plotter systems					



2.5 mm²/5 mm wide

4 mm²/6 mm wide

10 mm²/10 mm wide 16 mm²/12 mm wide 35 mm²/16 mm wide

Type	Part No.	Std. Pack	Type	Part No.	Std. Pack	Type	Part No.	Std. Pack		
Marking strips, unmarked			Marking strips, unmarked			10 mm²/10 mm wide				
9705 A/5/10	04.242.5053.0	25	9705 A/6/10	04.242.6053.0	25	marked for 5 blocks (every 2nd tag) *				
Marking strips, marked			Marking strips, marked			16 mm²/12 mm wide				
9705 A/5/9 B	1-9	04.842.4953.0	25	9705 A/6/9 B	1-9	04.842.5953.0	25	9705 A/5/10/5 B	04.842.5553.0	25
9705 A/5/10 B*		04.842.5053.0	25	9705 A/6/10 B*		04.842.6053.0	25	marked for 5 blocks (every 2nd tag) *		
9705 A/5/10 B	1-10	04.845.0153.0	25	9705 A/6/10 B	1-10	04.846.0153.0	25	35 mm²/16 mm wide		
	11-20	04.845.0253.0	25		11-20	04.846.0253.0	25	marked for 5 blocks (every 2nd tag) *		
	21-30	04.845.0353.0	25		21-30	04.846.0353.0	25	9705 A/6/10/5 B		
	31-40	04.845.0453.0	25		31-40	04.846.0453.0	25	04.842.6553.0		
	41-50	04.845.0553.0	25		41-50	04.846.0553.0	25	25		
	51-60	04.845.0653.0	25		51-60	04.846.0653.0	25			
	61-70	04.845.0753.0	25		61-70	04.846.0753.0	25			
	71-80	04.845.0853.0	25		71-80	04.846.0853.0	25			
	81-90	04.845.0953.0	25		81-90	04.846.0953.0	25			
	91-100	04.845.1053.0	25		91-100	04.846.1053.0	25			
	⊕ (10 x)	04.855.0053.0	25		⊕ (10 x)	04.856.0053.0	25			
	± (10 x)	04.855.0153.0	25		± (10 x)	04.856.0153.0	25			
	+	04.855.0253.0	25		+	04.856.0253.0	25	marked for 5 blocks (every 2nd tag) *		
	-	04.855.0353.0	25		-	04.856.0353.0	25	9705 A/8/10/5 B		
	L1	04.855.0453.0	25		L1	04.856.0453.0	25	04.842.8553.0		
	L2	04.855.0553.0	25		L2	04.856.0553.0	25	25		
	L3	04.855.0653.0	25		L3	04.856.0653.0	25			
	PE	04.855.0753.0	25		PE	04.856.0753.0	25			
	SL	04.855.3153.0	25		SL	04.856.3153.0	25			
	N	04.855.3253.0	25		N	04.856.3253.0	25			
	F1	04.855.0953.0	25		F1	04.856.0953.0	25			
	F2	04.855.1053.0	25		F2	04.856.1053.0	25			
	L1, L2, L3, N, PE	(2 x) 04.855.0853.0	25		L1, L2, L3, N, PE	(2 x) 04.856.0853.0	25			
with enlarged marking area			with enlarged marking area							
9705 AL/5/10	04.242.5153.0	25	9705 AL/6/10	04.242.6353.0	25					
* Custom marking upon request			* Custom marking upon request			* Specify required marking with part no.				

Ferrules for DIN rail terminal blocks

fasis

Ferrules with insulating material sleeve

Materials:

Sleeve: Polypropylene, temperature resistance 105 °C, creepage resistant

Tube: E-Cu, galvanically tin-plated

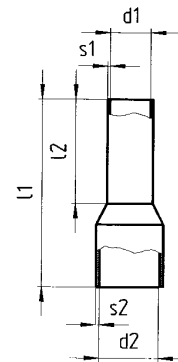

Ferrules without insulating material sleeve

Material:

Tube: E-Cu, galvanically tin-plated

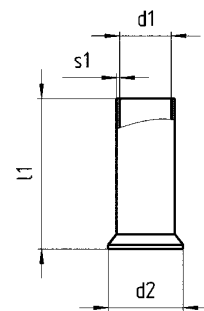

	Cross section mm ²	Color	Part No.	Std. Pack	
Ferrules with insulating material sleeve	0.50	norm.	white	06.600.2027.0	100
according to DIN 46 228 T4	0.75	norm.	gray	06.600.2127.0	100
	1.00	norm.	red	06.600.2227.0	100
	1.50	norm.	black	06.600.2327.0	100
	1.50	long	black	06.600.2427.0	100
	2.50	norm.	blue	06.600.2527.0	100
	2.50	long	blue	06.600.2627.0	100
	4.00	norm.	gray	06.600.2727.0	100
	4.00	long	gray	06.600.2827.0	100
	6.00	norm.	yellow	06.600.2927.0	100
	6.00	long	yellow	06.600.3027.0	100
	10.00	norm.	red	06.600.3127.0	100
	10.00	long	red	06.600.3227.0	100
	16.00	norm.	blue	06.600.3327.0	100
	16.00	long	blue	06.600.3427.0	100
	25.00	halblong	yellow	06.600.3527.0	50
Ferrules without insulating material sleeve	0.50	norm.		06.600.4027.0	1000
according to DIN 46 228 T1	0.75	norm.		06.600.4127.0	1000
	1.00	norm.		06.600.4227.0	1000
	1.50	norm.		06.600.4327.0	1000
	2.50	norm.		06.600.4427.0	1000
	4.00	norm.		06.600.4527.0	1000
	6.00	norm.		06.600.4627.0	500
	10.00	norm.		06.600.4727.0	500
	16.00	norm.		06.600.4827.0	100
	25.00	norm.		06.600.4927.0	100
	35.00	norm.		06.600.5027.0	100

DIN rail terminal blocks for junction boxes with spring clamp connection, type *WKF/WKIF/WKIS*



„We at Wieland“ know what you need!

For more than 90 years we have been your competent partner in the field of connection technology for your products. Close cooperation with our customers helps to create innovative products manufactured according to the highest quality standards.

Increasing automation as well as the safety functions to be implemented inside buildings increase the requirements for power and signal management in electrical distribution systems. The growing number of circuits and the increasingly confined space available requires a DIN rail terminal block system that reduces the amount and costs of cabling but still enables clear and convenient wiring.

Wieland's DIN rail terminal blocks provide you with the right solution.

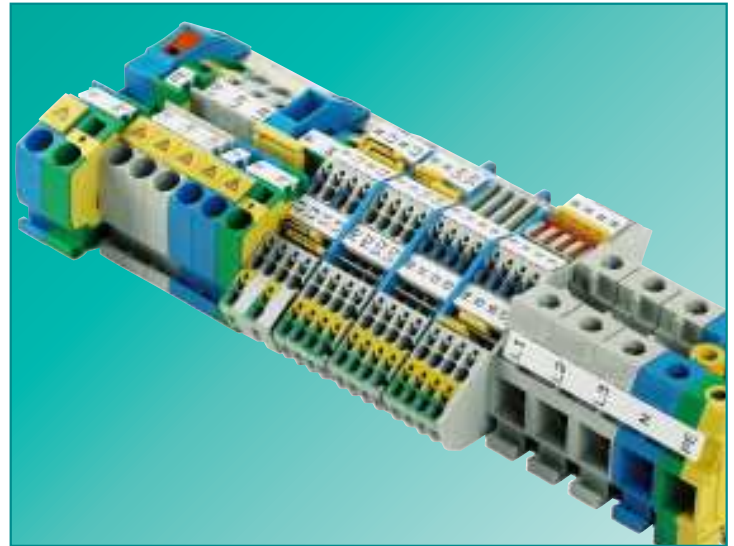

selos/fasis BIT

The right solution for your application

All DIN rail terminal blocks of the BIT series comply with the directives for the setup of high-voltage and supply systems for safety services according to VDE 0108 and have been designed for use in public buildings. Isolation measurement, for example, can be carried out with the wires connected.

You have the choice. The connection technology can be implemented either in purely spring clamp or screw technology or they can be mixed together.

fasis BIT-S Type WKIS...

DIN rail terminal blocks with push-in spring

The new installation blocks of series *fasis* BIT-S with push-in are an outstanding extension to the existing product range.

fasis BIT-S helps to increase efficiency in electrical installations even more, since rigid as well as flexible wires with ferrules can be directly connected without opening the termination point thus achieving considerable time savings.

fasis BIT Type WKF/WKIF...

DIN rail terminal blocks with tension spring

The tension spring technology of series *fasis* BIT stands out due to its maintenance-free and vibration-proof connection technology. The TOP connection is especially suitable for confined spaces.

Due to its great product variety and a wire range between 0.5 mm² and 16 mm² the *fasis* BIT series enables many innovative solutions for various requirements.

selos BIT Type WK/WKI...

DIN rail terminal blocks with screw connection

The screw connection technology of series *selos* BIT is the best known and most widely used connection technology worldwide. The lateral connection option makes wiring more convenient in installations, especially on the supply side and in the case of larger cross sections.

The user-friendly *selos* BIT series can be used universally in the wire range between 0.5 mm² and 50 mm².